

DIGITAL SOUND FIELD PROCESSING AMPLIFIER

DSP-A3090

SERVICE MANUAL

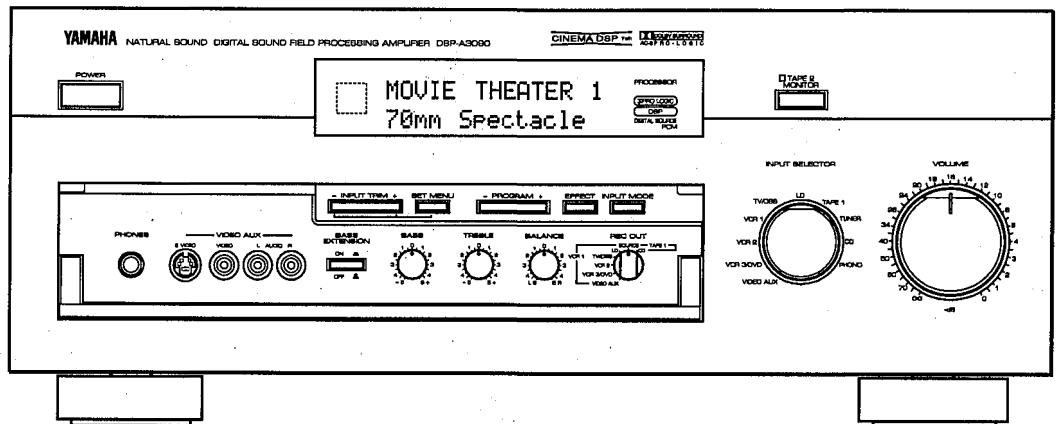
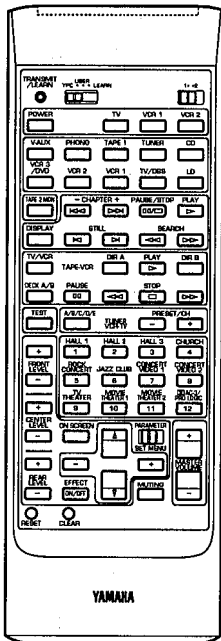

IMPORTANT NOTICE

This manual has been provided for the use of authorized YAMAHA Retailers and their service personnel. It has been assumed that basic service procedures inherent to the industry, and more specifically YAMAHA Products, are already known and understood by the users, and have therefore not been restated.

WARNING: Failure to follow appropriate service and safety procedures when servicing this product may result in personal injury, destruction of expensive components and failure of the product to perform as specified. For these reasons, we advise all YAMAHA product owners that all service required should be performed by an authorized YAMAHA Retailer or the appointed service representative.

IMPORTANT: The presentation or sale of this manual to any individual or firm does not constitute authorization, certification or recognition of any applicable technical capabilities, or establish a principle-agent relationship of any form.

The data provided is believed to be accurate and applicable to the unit(s) indicated on the cover. The research, engineering, and service departments of YAMAHA are continually striving to improve YAMAHA products. Modifications are, therefore, inevitable and specifications are subject to change without notice or obligation to retrofit. Should any discrepancy appear to exist, please contact the distributor's Service Division.

WARNING: Static discharges can destroy expensive components. Discharge any static electricity your body may have accumulated by grounding yourself to the ground buss in the unit (heavy gauge black wires connect to this buss).

IMPORTANT: Turn the unit OFF during disassembly and parts replacement. Recheck all work before you apply power to the unit.

CONTENTS

TO SERVICE PERSONNEL	1	IC DATA	23~36
REAR PANELS	1~2	IC BLOCKS	37~42
SPECIFICATIONS	3	DISPLAY DATA	43~44
INTERNAL VIEW	4	PIN CONNECTION DIAGRAM	45
SET MENU TABLE	4	PRINTED CIRCUIT BOARD	46~67
DISASSEMBLY PROCEDURES	5	REMOTE CONTROL TRANSMITTER	68~69
ADJUSTMENTS	6	BLOCK DIAGRAM	70
SELF DIAGNOSIS FUNCTION	7~21	SCHEMATIC DIAGRAM	71~77
TEST POINT WAVEFORMS	22	PARTS LIST	78~101

100535

YAMAHA
YAMAHA CORPORATION
P.O.Box 1, Hamamatsu, Japan

3.4K-806 □ ⊕ Printed in Japan '96.3

DSP-A3090

■ TO SERVICE PERSONNEL

1. Critical Components Information.
Components having special characteristics are marked and must be replaced with parts having specifications equal to those originally installed.
2. Leakage Current Measurement (For 120V Models Only).
When service has been completed, it is imperative to verify that all exposed conductive surfaces are properly insulated from supply circuits.
 - Meter impedance should be equivalent to 1500 ohm shunted by 0.15 μ F.
 - Leakage current must not exceed 0.5mA.
 - Be sure to test for leakage with the AC plug in both polarities.

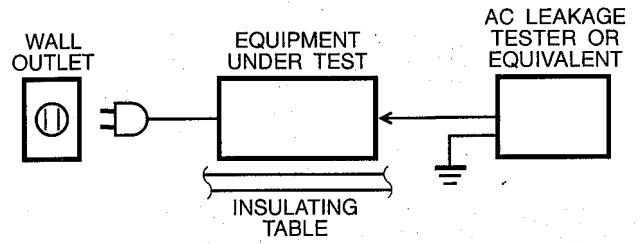

WARNING: CHEMICAL CONTENT NOTICE!

The solder used in the production of this product contains LEAD. In addition, other electrical/electronic and/or plastic (where applicable) components may also contain traces of chemicals found by the California Health and Welfare Agency (and possibly other entities) to cause cancer and/or birth defects or other reproductive harm.

DO NOT PLACE SOLDER, ELECTRICAL/ELECTRONIC OR PLASTIC COMPONENTS IN YOUR MOUTH FOR ANY REASON WHATSOEVER!

Avoid prolonged, unprotected contact between solder and your skin! When soldering, do not inhale solder fumes or expose eyes to solder/flux vapor!

If you come in contact with solder or components located inside the enclosure of this product, wash your hands before handling food.

DSP-A3090

■ REAR PANELS

▼ R model

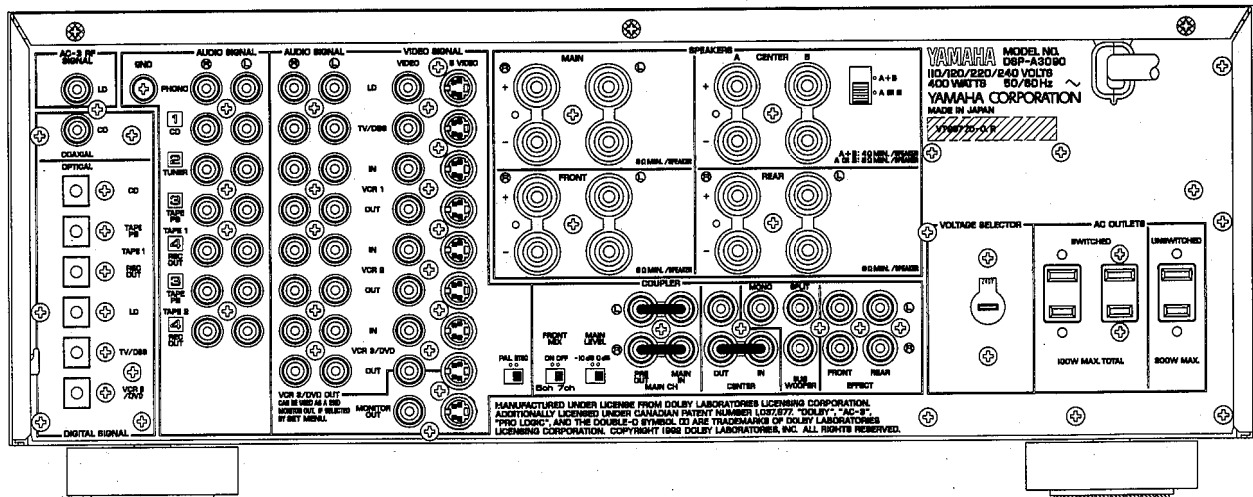

▼ U model

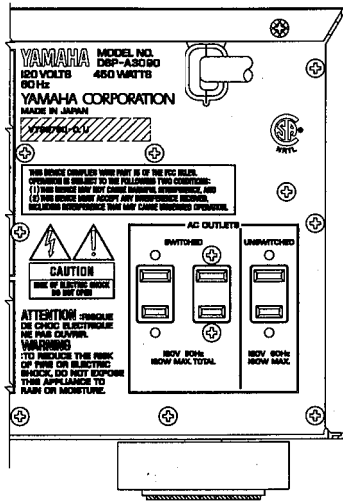

▼ B model

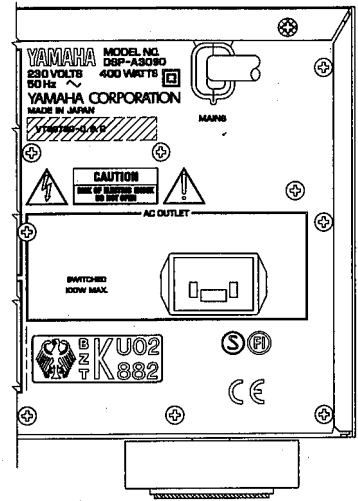

▼ C model

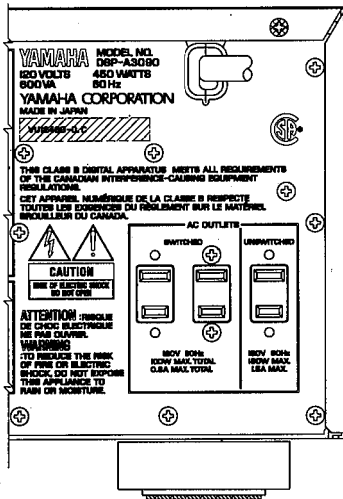

▼ G model

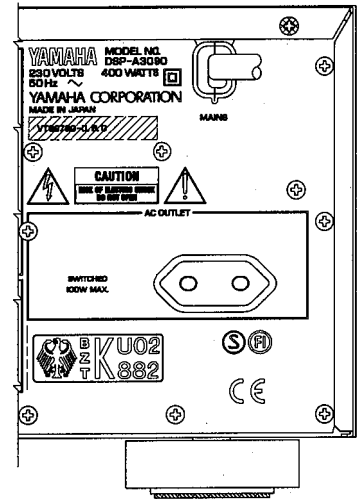

▼ A model

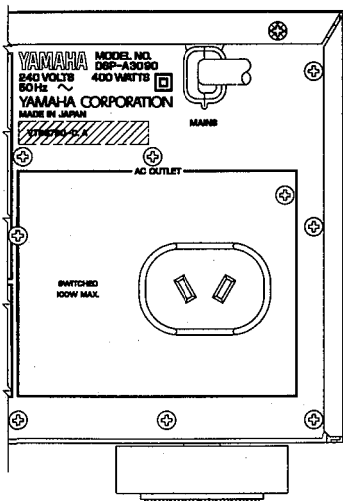

DSP-A3090

Manufactured under license from Dolby Laboratories Licensing Corporation. Additionally licensed under Canadian patent number 1,037, 877. "Dolby", "AC-3", "PRO LOGIC", and the double-D symbol $\square\square$ are trademarks of Dolby Laboratories Licensing Corporation. Copyright 1992 Dolby Laboratories, inc. all rights reserved.

■ SPECIFICATIONS

Minimum RMS Output Power Per Channel		
Main (20Hz—20kHz 0.015% THD 8Ω)		80W
Center (20Hz—20kHz 0.015% THD 8Ω)		80W
Rear (20Hz—20kHz 0.015% THD 8Ω)		80W
Front (1kHz 0.05% THD 8Ω)		25W
Dynamic Power Per Channel		
(by IHF Dynamic Headroom Measuring Method)		
(U, C, R models) Main (8Ω/6Ω/4Ω)		100W/120W/160W
DIN Standard Output Power Per Channel (B, G models)		
Main (1kHz 0.7% THD 4Ω)		130W
Dynamic Headroom (U, C, R models)		
Main (8Ω)		0.97dB
IEC Power (B, G models)		
Main (1kHz 0.015% THD 8Ω)		85W
Damping Factor		
Main, Center (20Hz—20kHz 8Ω)		200
Input Sensitivity/Impedance		
Phono MM		2.5mV/47kΩ
CD etc		150mV/47kΩ
MAIN IN/CENTER IN		1.0V/47kΩ
Maximum Input Signal (1kHz 0.05% THD)		
Phono MM		130mV
CD etc		2.3V
Output Level/Impedance		
REC OUT		150mV/1kΩ
PRE OUT (MAIN L, R, CENTER)		1V/1.2kΩ
PRE OUT (FRONT L, R, REAR L, R)		1V/1.2kΩ
PRE OUT (SPLIT L, R)		2.0V/1.2kΩ
PRE OUT (MONO)		3.4V/1.2kΩ
Maximum Voltage Output (20Hz—20kHz 1% THD)		
PRE OUT (MAIN L, R)		3V
Headphone Jack Rated Output/Impedance		
Input 50mV RL=8Ω		0.2V
Impedance		100Ω
Frequency Response (20Hz—20kHz)		
CD etc		0±0.5dB
RIAA Equalization Deviation (20Hz—20kHz)		
Phono MM		0±0.5dB
Total Harmonic Distortion (20Hz—20kHz)		
Phono MM to REC OUT, 3V		0.01%
CD etc to PRE OUT (MAIN L, R), 1V		0.005%
MAIN IN to SP out (MAIN L, R, CENTER)		0.005%
40W/8Ω		0.005%
Signal-to-Noise Ratio (IHF-A Network)		
Phono MM (Input Shorted), 5mV		More than 86dB
CD etc (Input Shorted), 150mV		More than 96dB
Residual Noise (IHF-A Network)		
MAIN L, R SP out		150μV
Channel Separation (Vol -30dB)		
Phono MM Input shorted		
1kHz/10kHz		More than 70dB/60dB
CD etc Input 5.1kΩ Terminated		
1kHz/10kHz		More than 70dB/60dB
Tone Control Characteristics		
Bass		
Boost/Cut		±10dB (50Hz)
Turnover frequency		350Hz
Treble		
Boost/Cut		±10dB (20kHz)
Turnover frequency		3.5kHz
Center Graphic Equalizer		
Frequency		100/300/1k/3k/10k
Boost/Cut		±6dB
Q		0.7
Cinema Equalizer		
High Shelving Filter		
Frequency		1k to 12.7kHz
Boost/Cut		-9 to +6dB
Parametric Equalizer		
Frequency		1k to 12.7kHz
Boost/Cut		-9 to +6dB
Q		1.85

Low Pass Filter Characteristics (Super Woofer)		
High cut Filter		fc=90Hz, 24dB/oct
BASS EXTENSION (Main L, R)		
		+6dB (70Hz)
AUDIO MUTING		
		-20dB
Video		
Video Signal Type		
(U, C models)		NTSC
(A, B, H, W models)		PAL
(R model)		NTSC/PAL
Video Signal Level		
		1Vp-p/75Ω
S-Video Signal Level		
Y		1Vp-p/75Ω
C		0.286Vp-p/75Ω
Maximum Input Level		
		More than 1.5Vp-p
Video S/N		
		50dB
Monitor Out Frequency response		
		5Hz—10MHz, -3dB
Power Supply		
U, C models		
		AC120V 60Hz
A model		
		AC240V 50Hz
B, G models		
		AC230V 50Hz
R model		
		AC110/120/220/240V 60/50Hz
Power Consumption		
U model		
		450W
C model		
		450W, 600VA
A, B, G, R models		
		400W
AC Outlets		
2 Switched Outlets		
(U model)		
		120W max. total
(C, R models)		
		100W max. total
1 Switched Outlets		
(A, B, G models)		
		100W max. total
1 Unswitched Outlets		
(U, C models)		
		180W max. total
(R model)		
		200W max. total
Dimensions (W x H x D)		
		435 x 170 x 476.5mm
		(17-1/8" x 6-11/16" x 18-3/4")
Weight		
		21.0kg (46 lbs. 4 oz)

*Specifications are subject to change without notice.

U U. S. A. model A Australian model
 C Canadian model G European model
 B British model R General model

● DIMENSIONS

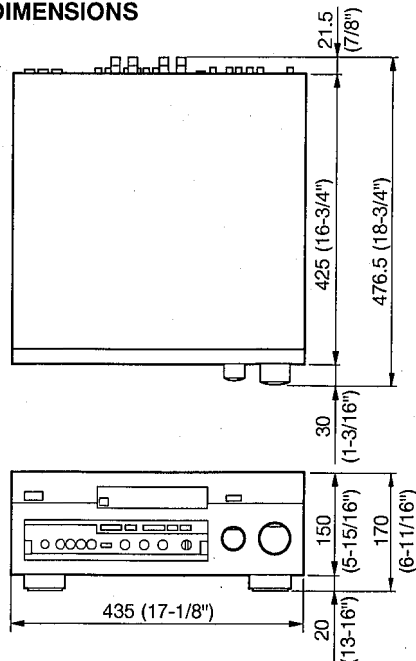

Units : mm (inch)

INTERNAL VIEW

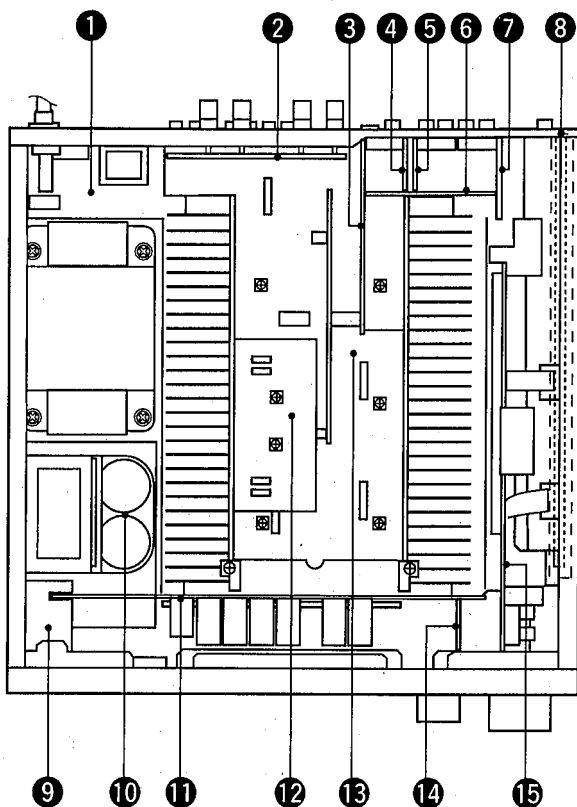

- ① VIDEO P.C.B. (6)
- ② MAIN P.C.B. (2)
- ③ VIDEO P.C.B. (1)
- ④ VIDEO P.C.B. (2)
- ⑤ VIDEO P.C.B. (4)
- ⑥ FUNCTION P.C.B. (5)
- ⑦ DSP P.C.B. (2)
- ⑧ DSP P.C.B. (1)
- ⑨ DSP P.C.B. (4)
- ⑩ MAIN P.C.B. (3)
- ⑪ VIDEO P.C.B. (3)
- ⑫ VIDEO P.C.B. (5)
- ⑬ MAIN P.C.B. (1)
- ⑭ FUNCTION P.C.B. (7)
- ⑮ FUNCTION P.C.B. (1)

DSP-A3090

SET MENU TABLE

No.	SET MENU	PRESET VALUE	SETTING RANGES
1.	SPEAKER SET		CENTER, REAR, MAIN, LFE/BASS
1A	CENTER SPEAKER	NORMAL	NORMAL/WIDE/PHANTOM
1B	REAR SPEAKER	SMALL	SMALL/LARGE
1C	MAIN SPEAKER	LARGE	SMALL/LARGE
1D	LFE/BASS OUT	SUBWOOFER	MAIN/SUBWOOFER/BOTH
2.	LOW FREQ. TEST	OFF/88Hz MAIN L	ON/OFF, FRQ: 35 — 250Hz L/C/R/RS/LS/SW/FRONT
3.	LFE LEVEL	0dB	MUTE, -20dB — 0dB
4.	CENTER DELAY	0ms	0ms — 5ms
5.	CENTER GRAPHIC EQ.	EACH 0dB	100Hz — 10kHz, -6dB — +6dB
6.	CINEMA EQ.	ALL "OFF"	L, C, R EQ/FRONT EQ/REAR EQ ON/OFF
6A	L, C, R EQ.	HIGH 12.7kHz, -3dB PEG 12.7kHz, -4dB	HIGH, PGE: 1kHz — 12.7kHz
6B	FRONT EQ.	HIGH 12.7kHz, 0dB PEG 8kHz, -3dB	GAIN: -9dB — +6dB
6C	REAR EQ.	HIGH 12.7kHz, 0dB PEG 8kHz, -3dB	
7.	DYNAMIC RANGE	MAX	MAX/STD/MIN
	STD: HIGH LEVEL CUT SCALE	1.0	0.0 — 1.0
	LOW LEVEL BOOST SCALE	1.0	0.0 — 1.0
8.	PARAMETER INITIALIZE	OFF	PROGRAM 1 — 12
9.	MEMORY GUARD	OFF	ON/OFF
10.	VCR3 VIDEO OUT	REC OUT	REC OUT/MONITOR
11.	INPUT LEVEL TRIM	0dB	0, +2, +4, +6dB
12.	INPUT MODE	AUTO TV/DBS VCR3/DVD	AUTO/LAST
13.	DIMMER	0	-4 — 0

■ DISASSEMBLY PROCEDURES

(Remove parts in disassembly order as numbered.)

1. Removal of Top Cover

- a. Remove 4 screws (①) and 3 screws (②) and then remove the Top Cover in Fig. 1.

2. Removal of Bottom Cover

- a. Remove 12 screws (③) and then remove the Bottom Cover in Fig. 1.

3. Removal of Front Panel

- a. Remove 2 knobs in Fig. 1.
- b. Remove 4 screws (④) and then remove the Front Panel in Fig. 1.

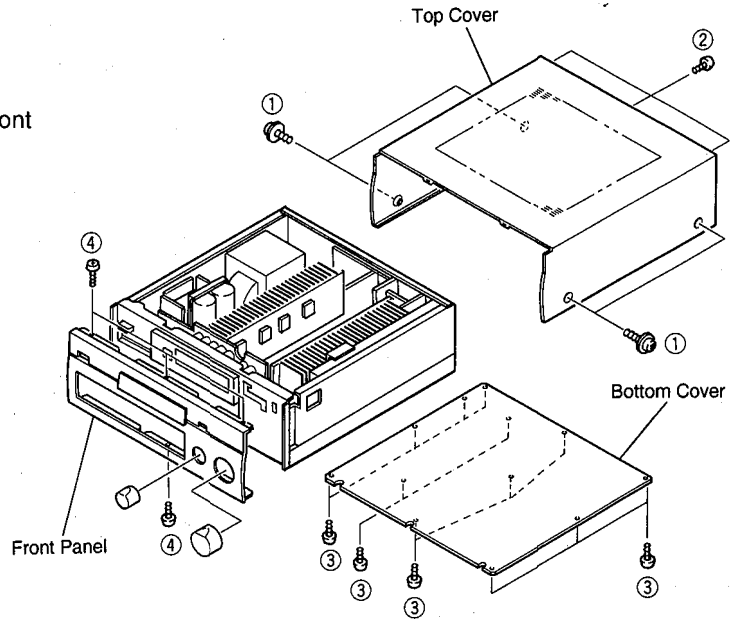

Fig. 1

4. Removal of DSP PCB (2)

- a. Remove 16 screws (⑤) and remove the right upper frame. (Fig. 2)
- b. Remove connectors #6 and #7. (Fig. 2)
- c. Remove 7 screws (⑥) and remove the DSP P.C.B. (1). (Fig. 2)

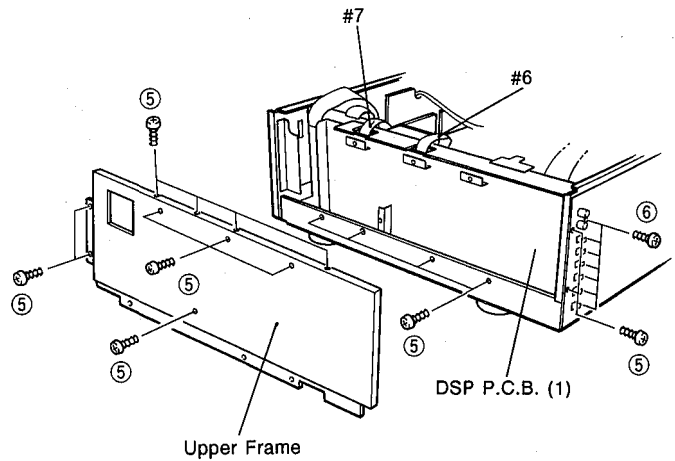

Fig. 2

Note :

1. When the rear panel has been removed, the ground wire of the input/output pin jack becomes loose. Connect it to the chassis by using a lead wire.

■ ADJUSTMENTS

● IDLING CURRENT ADJUSTMENT

Before this adjustment, wait for 10 minutes with no signal applied after the power is turned ON.

Item	Test Point	Adjustment point	Rating (DC)
MAIN L	Between terminals of R394, at the center and one end	VR304 (MAIN P.C.B.)	2.5mV~5mV
MAIN R	Between terminals of R393, at the center and one end	VR303 (MAIN P.C.B.)	
CENTER	Between terminals of R445, at the center and one end	VR305 (MAIN P.C.B.)	2.5mV~5mV
REAR L	Between terminals of R511, at the center and one end	VR301 (MAIN P.C.B.)	2.5mV~5mV
REAR R	Between terminals of R517, at the center and one end	VR302 (MAIN P.C.B.)	
FRONT L	Between terminals of R308 or R309, at both ends	VR301 (VIDEO P.C.B.)	2.5mV~5mV
FRONT R	Between terminals of R313, or R314, at both ends	VR302 (VIDEO P.C.B.)	

● Test Point

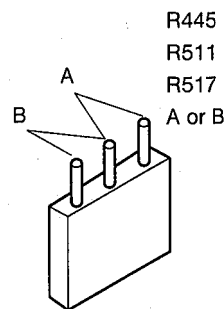
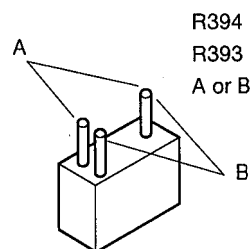
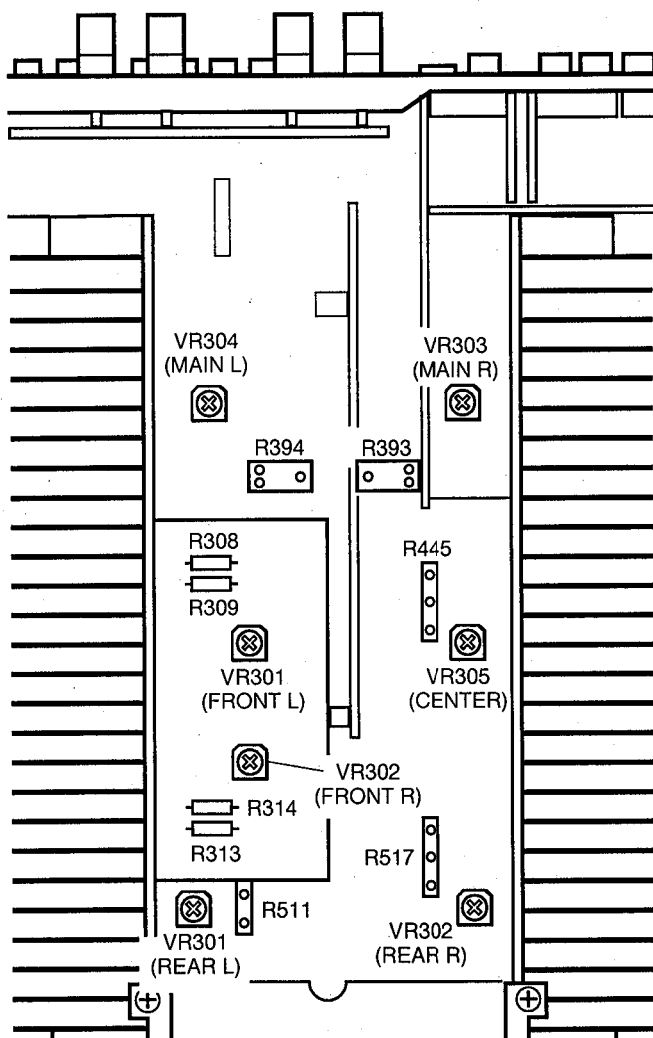

■ SELF DIAGNOSIS FUNCTION

This product has a self diagnosis function(DIAG) to facilitate inspection, measurement and determination of a faulty item. There are No.1 to No.12 diagnosis menus and each menu has some sub-menus.

No. Diagnosis menu	Sub-menu	No. Diagnosis menu	Sub-menu	
1. ANALOG THR.	MAIN BYPASS	7. MANUAL TEST	ALL	
	DSP 0dB		MAIN L	
DSP FULL BIT	CENTER			
2. DSP RAM THR.	ZR→S→C→PS RAM		MAIN R	
	ZR→SDSP→CDSP		REAR R	
	ZR→CDSP		REAR L	
	CDSP DIRECT		FRONT R	
3. AC-3 THR.	P1(ZR38500 decode information 1)		FRONT L	
	P2(ZR38500 decode information 2)		LFE	
	P3(ZR38500 decode information 3)		8. PRESET	INHIBITED (memory initialization inhibited) RESERVED (memory initialized)
4. PRO LOGIC	CENTER NORMAL		9. DISPLAY CHK	EFFECT OFF DISPLAY CHECK
	CENTER WIDE		10. AD DATA CHK	EFFECT OFF DC PROTECTION, PS PROTECTION, FRONT MIX SW REC OUT, INPUT 1, INPUT 2, KEY
	CENTER PHANTOM	11. VERSION CHK		MAIN & SUB CPU VERSION ZR38500 VERSION
	EFFECT OFF	12. EXIT	EXIT (INFORMATION)	
5. SPEAKERS SET	MAIN SP LARGE			
	MAIN SP SMALL			
	REAR SP LARGE			
	REAR SP SMALL			
	LFE/BASS SW			
	LFE/BASS MAIN			
6. ANALOG INPUT	INPUT TRIM 0dB			
	INPUT TRIM +2dB			
	INPUT TRIM +4dB			

● Trouble causes that can be checked by DIAG

Trouble symptom	Possible cause and check method by using DIAG
Digital sound is not produced	Failure in signal path : Check for faulty IC with the signal path changed by using Menu No.2.
	Failure of AC-3 decoder (ZR38500) : Check the decode information by using Menu No.3P1.
	Failure of ZR external ROM : Check the version of ZR38500 by using Menu No.11.
	Malfunction of sub-CPU : Check the version or CPU by using Menu No.11 and communication operation by using Menu No.12.
	Malfunction of digital input, DIR(YM3436) : Check the fs information, digital source information, etc. by using Menu No.12.
	Malfunction of CDSP(YSS214) : As it is undetectable by using DIAG, check the signals before and after CDSP.
	Malfunction of DAC (AK4320) : As it is undetectable by using DIAG, check the signals before and after DAC. The test tone of this product is output from the noise generator which is built in the CDSP (YSS214) through DAC (AK4320). If the test tone is not output through the connector #7 of the DSP circuit board, an abnormality exists in either CDSP or DAC.
AC-3 sound is not produced	Failure of connector #7 : Check soldering, the flat connecting cable, pattern, etc.
	Check each item (particularly malfunction of ZR) for the above symptom "Digital sound is not produced."
	Failure of RF input or DEM (PD4606) : An abnormality exists if "1" is detected at the MUTO terminal (3rd bit) in Menu No.12 (first data).
	The source is not usable for AC-3 : The source is usable for AC-3 if "1.0" is detected at the 5th and 6th bits in Menu No.12 (first data). The AC-3 decode source without the digital data bit (CD-ROM, DAT, etc.) is reproducible only in Menu No.3.
PRO LOGIC sound is not produced	Malfunction of SDSP(YSS213) : Check the signal in both paths using/not using SDSP in Menu No.2.
	Malfunction of A/D(AK5390) (at analog input) : An abnormality exists if the fs information is other than "1.0" (48kHz) in Menu No.12.
EFFECT sound is not produced	Malfunction of PS-RAM : Check the signal in both paths using/not using PS-RAM in Menu No.2.
	Failure of electronic volume : As it is undetectable by using DIAG, check the signals before and after the volume, the control signal from CPU, etc.

Trouble symptom	Possible cause and check method by using DIAG
Power turns OFF after being turned ON (The protection function works.)	Check for the faulty part by using the history of protection function (3 types) when starting DIAG. Failure of detection circuit, connectors (#3, #4, etc.) : Check for the constant, soldering condition, flat connecting cable coming off, pattern, etc.

If an failure in the digital system is anticipated, check whether there is an analog output at the connector #7 of the DSP circuit board in addition to the above check items. If there is a correct output, a failure exists after DSP. Check whether a signal exists or not in the analog section before the volume (connector #7 of the function circuit board) and after it (connector #1 of the function circuit board), pre-out, etc. Also, such malfunction does not necessarily mean a malfunction of the IC itself. Check for poor soldering condition, peripheral pattern, control signal from CPU, connector, power supply, etc. at the same time.

● Starting DIAG

Press the "POWER" key of the main unit while pressing the "INPUT TRIM +" key and the "SET MENU" key located within the sealing panel of the main unit, and DIAG starts to function.

● Canceling DIAG

There are two ways to cancel DIAG.

- 1) Turn OFF the power by pressing the "POWER" key of the main unit or the remote controller.
- 2) Cancel the DIAG function by using the DIAG menu No.12, EXIT. Then DIAG ends and the normal state is restored.

CAUTION : When canceling this function, check the DIAG menu No.8 PRESET (for memory initialization inhibit/reserve).
(To keep the user memory, be sure to select "INHIBITED" from setting items of No.8 PRESET menu to inhibit initialization before canceling the diagnosis function.)

● Display at the start of DIAG

The diagnostic menu appears on the monitor display. (It remains on display till it is canceled.)
On the FL display of the main unit, an opening message appears for 2 seconds before the diagnostic menu.

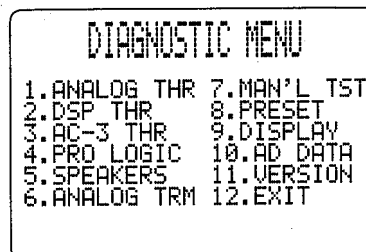
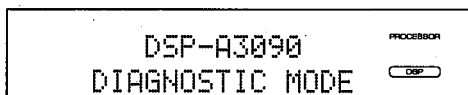

● If the protection function works after DIAG has been started and the power turns OFF

When the protection function works, the hysteresis of the protection is displayed and the power turns OFF.
 Repair the faulty parts according to the displayed hysteresis.

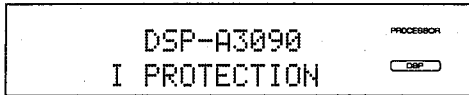

I PROTECTION display (The power turns OFF instantly.)

Cause : There is an abnormal current flow to the power amplifier.
 Supplementary information : As the current of the power transistor is checked in each channel, it is possible to determine the abnormal channel by checking the transistor where a current is detected.

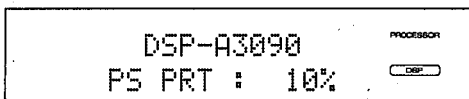

PS PRT display (The power turns OFF after about 2 seconds.)

Cause : There is an abnormality in the power supply section (voltage).
 Supplementary information : As the power from following sources is detected, it is possible to determine where an abnormality exists.

- Transformer secondary winding
- BE x 2(CB302), GY x 2(CB201), YE x 2(CB202)
- Stabilizing power source
- ±15, ±5V, +5D1, +5D2, -5D, VP

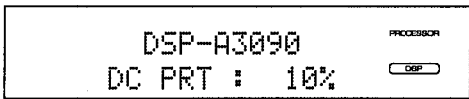

DC PRT display (The power turns OFF after about 2 seconds.)

Cause : The DC output of the power amplifier is detected in each channel.

Besides the above possible causes, the cause may exist in the connector which has come off or around CPU. Both PS PRT and DC PRT displays include the abnormal voltage value in %. (5V as 100%)

Even when the normal operation is restarted after repair, the hysteresis that the protection function worked is stored in memory and as a result, that hysteresis is displayed again after DIAG is started (for about 2 seconds) before the DIAG display.

To clear the hysteresis of the protection function, cancel DIAG by selecting "RESERVED" (to initialize the memory) from the setting items of the DIAG menu No.8 PRESET.

● Operation Procedure

DIAG menu selection

Main Unit : SET MENU (forward) key or PROGRAM +/- (forward/reverse) key

Remote Controller : Cursor key Δ/∇ (forward/reverse) or PROGRAM key (direct selection)

SUB-MENU selection

Main Unit : INPUT TRIM +/- (forward/reverse) key

Remote Controller : Cursor key +/- (forward/reverse) or PROGRAM key (Press the same No.)

It is possible to switch the input, adjust the front, center and rear levels, control the master volume, add muting and turn the power ON and OFF while DIAG is executed. However, the EFFECT/INPUT MODE key is not acceptable.

● Details of DIAG menu

1. ANALOG THR. (Analog through)

The input is fixed to use the analog (A/D) system and has 3 sub-menu items.

MAIN BYPASS

The main L/R signal is output through the analog bypass without passing the DSP section.
The main L/R signal passing through the DSP is output through C/LFE, FL/FR and RL/RR.

1. ANALOG THR.
MAIN BYPASS

CD INPUT : 1kHz, 150mV
VOLUME : MAX
PRE OUT : MAIN L/R $1.0 \pm 0.2V$
 CENTER $1.0 \pm 0.2V$
 REAR L/R $1.0 \pm 0.2V$
 FRONT L/R $1.0 \pm 0.2V$

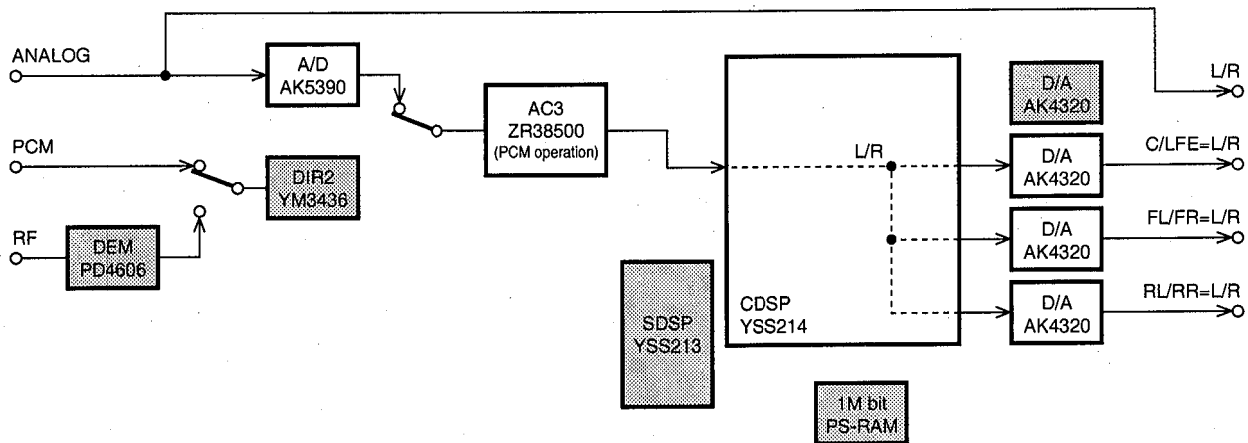

 The shaded square means that the element included in it does not operate.

DSP 0dB

The main L/R, C/LFE, FL/FR, RL/RR signals pass through the DSP section.

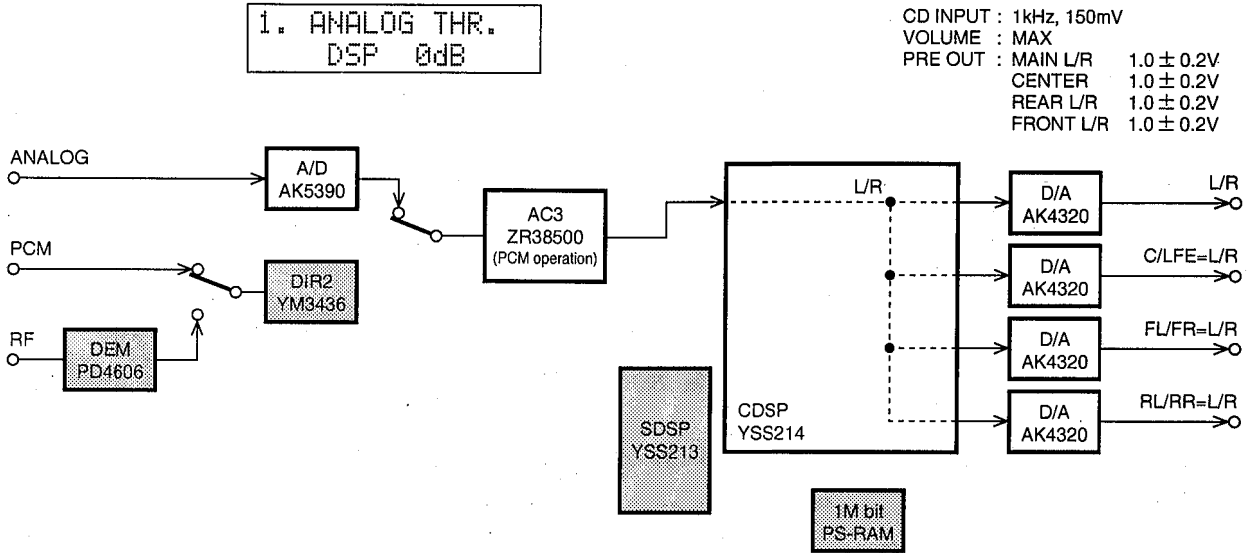

The shaded square means that the element included in it does not operate.

DSP FULL BIT

The same applies as "DSP 0dB" except that the digital data is output in full bit at D/A.



Full bit : The digital data is normally output with a head margin of 6dB for the center channel and 3dB for other channels. In this menu, however, the head margin is disused and the digital data is output in full bit so as to obtain the A/D and D/A characteristics fully. Note that this means the analog gain after D/A is +6dB for the center channel and +3dB for other channels.

2. DSP RAM THR.

Using this menu, it is possible to diagnose a trouble in ZR38500(IC13), YSS213(IC41), YSS214(IC18) and PS-RAM(IC19, 20) by switching the sub-menu and checking each output signal. There are 4 sub-menu items.

(The input data is automatically identified and switched in the priority order of RF → PCM → Analog (A/D) according to the signal detection.)

ZR → S → C → PS RAM

The main L/R signal is inputted through ZR38500 → SDSP to CDSP and after passing PS-RAM, it is output through all channels. (Signal paths are the same as in the normal operation.)

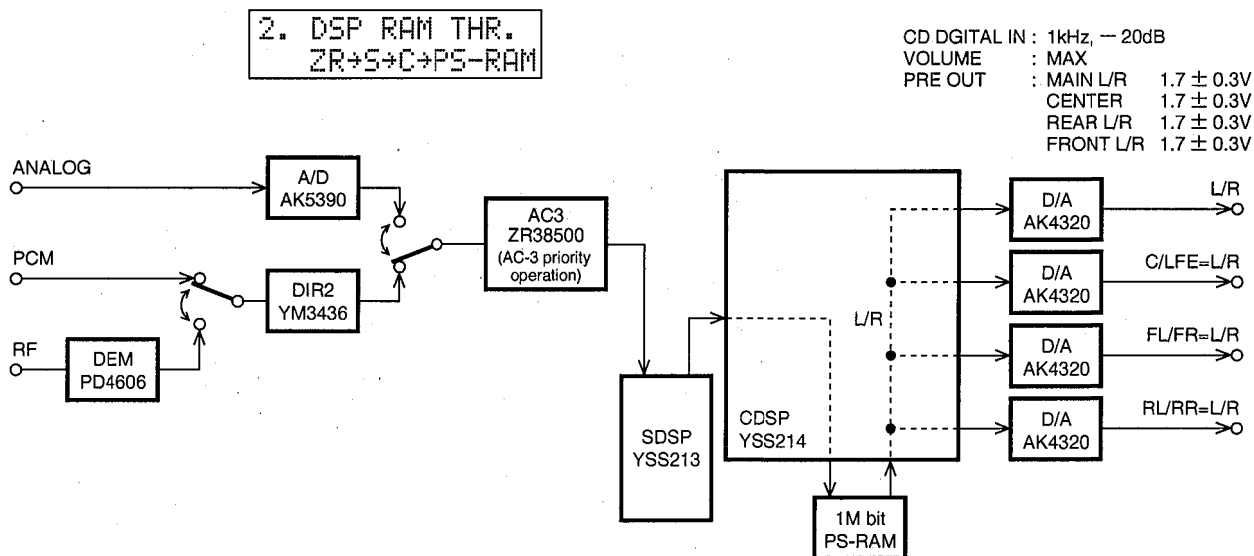

ZR → SDSP → CDSP

The main L/R signal is inputted through ZR38500 → SDSP to CDSP and then output through all channels. PS-RAM is bypassed.

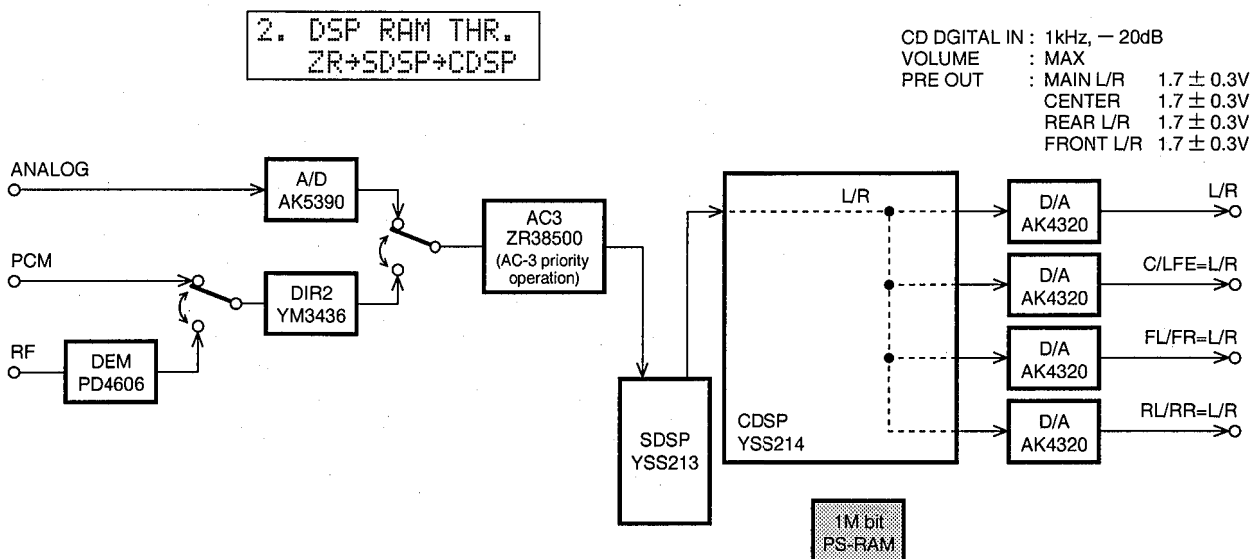

The shaded square means that the element included in it does not operate.

DSP-A3090

ZR → CDSP

The main L/R signal is inputted through ZR38500 to CDSP and then output through all channels. SDSP and PS-RAM are bypassed.

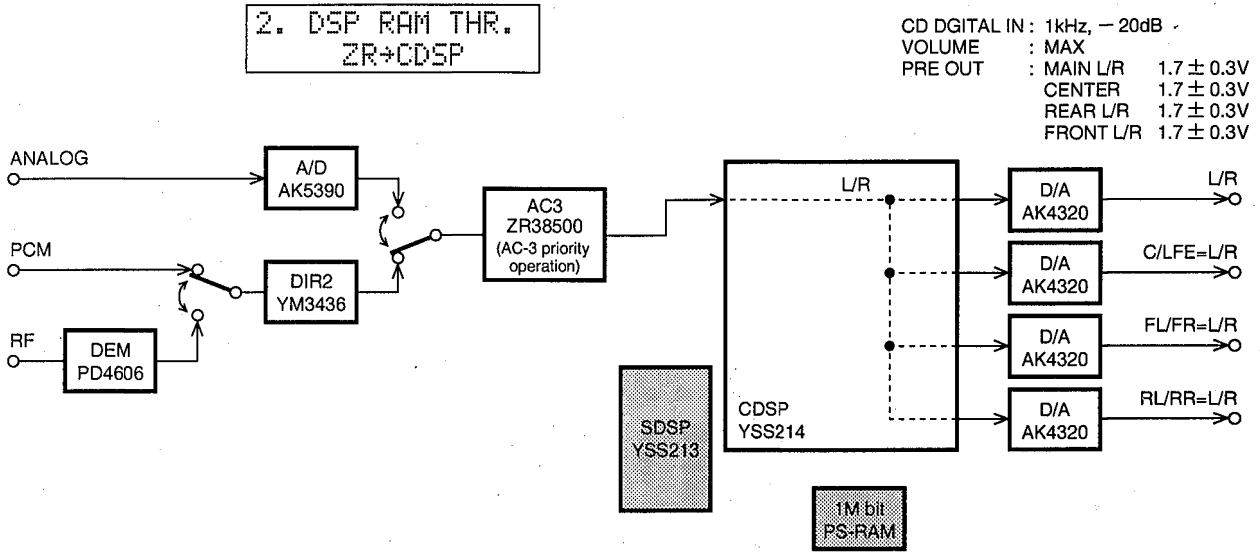

The shaded square means that the element included in it does not operate.

CDSP DIRECT

The main L/R signal is inputted directly to CDSP by DIR2 or A/D and output through all channels. ZR38500, SDSP and PS-RAM are bypassed.

Caution : No AC-3 decoding is executed as ZR38500 is bypassed. For this reason, when the AC-3 signal is inputted, the signal before decoding is output as a noise.

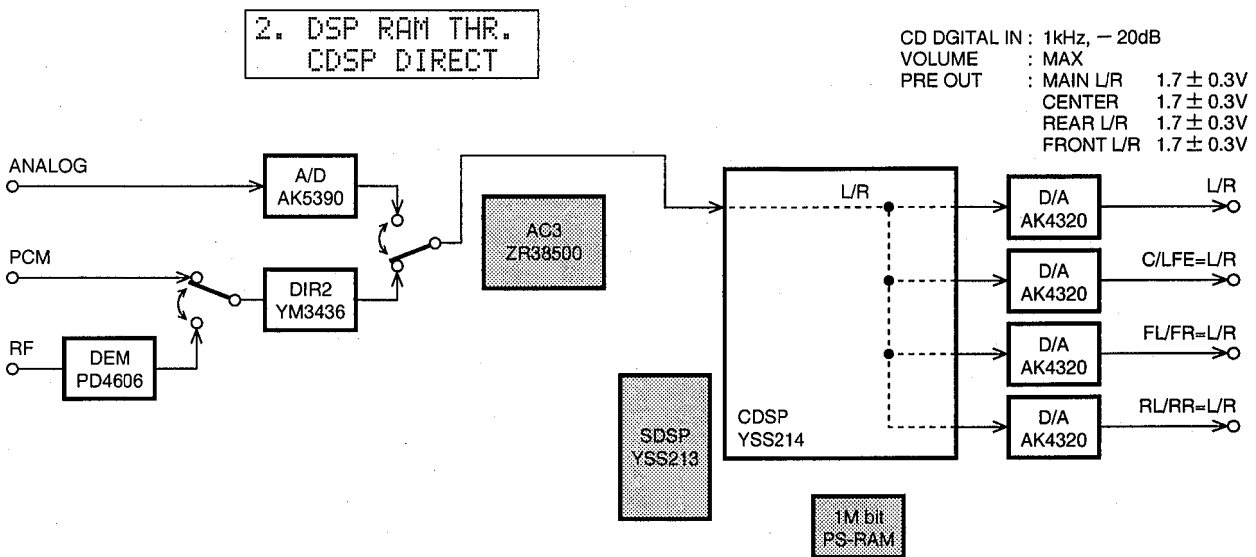

The shaded square means that the element included in it does not operate.

3. AC-3 THR.

The signal is inputted from RF or PCM. Regardless of the input source, the AC-3 signal is forced to be decoded and reproduced. (The AC-3 signal in each channel is decoded and output while passing through ZR38500 → CDSP.)

When operation is done for the sub-menu, the decode information for ZR38500 and AC-3 is displayed in 3 pages.

The decode information in P2 and P3 has nothing to do with servicing.

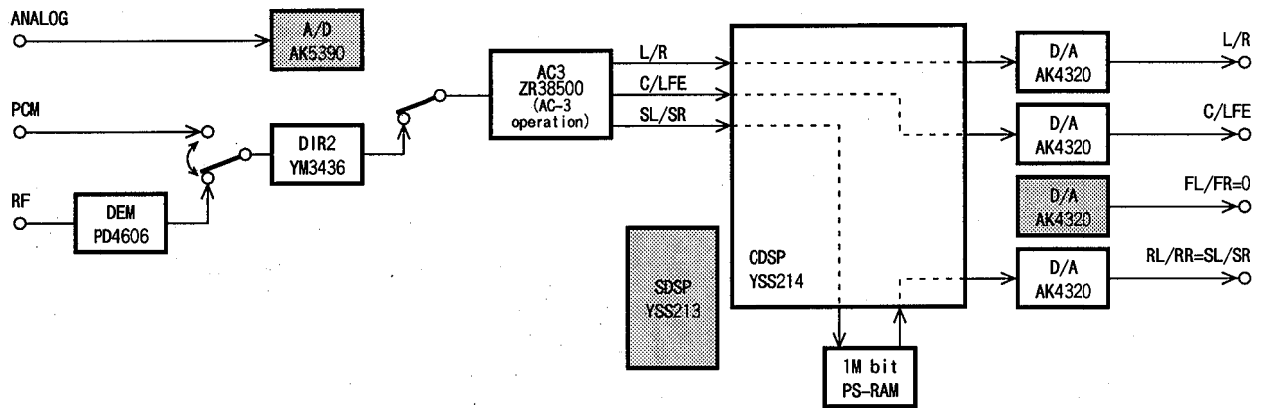

The shaded square means that the element included in it does not operate.

DSP-A3090

P1 : ZR38500 decode information

```
3. AC-3 THR.
P1: 05 00 1C 00
```

As signal identification is executed in normal AC-3 reproduction, the source (DAT, CD-ROM, etc.) without digital data bit cannot be reproduced even when it is AC-3 encoded. On the other hand, as this menu does not execute such digital data bit identification, these sources can be AC-3 reproduced. (To measure characteristics during AC-3 reproduction, use the AC-3 decoded sine wave.) However, note that with the sources that have not been AC-3 encoded, a decode error occurs and muting is applied. In addition, by displaying the status information indicating the operation of ZR38500 under the lower level of the FL display in hexadecimal notation, malfunction of the decoder can be detected. Refer to the examples given below for the decoding condition.

Normal AC-3 decode operation

```
3. AC-3 THR.
P1: 05 00 1C 0F
```

05 is indicated as the first data of P1 and 00 as the second data.

Reproduction of input source other than AC-3

```
3. AC-3 THR.
P1: 45 11 1C 0F
```

5 (means any number other than "0") is indicated as the first data and 00 as the second data.

Malfunction of ZR38500

```
3. AC-3 THR.
P1: FF FF FF FF
```

The lower 4 bits of the first data of P1 are other than 5.

4. PRO LOGIC

The same applies as the normal pro logic except that the auto input balance is OFF.

(The input data is automatically identified in the priority order of RF → PCM → Analog. AC-3 reproduction is executed when the AC-3 decode signal is inputted.)

The sub-menu items include selection of the center mode (normal, wide phantom) and EFFECT OFF. As this unit processes the entire center mode digitally within CDSP, it has no external analog circuit.

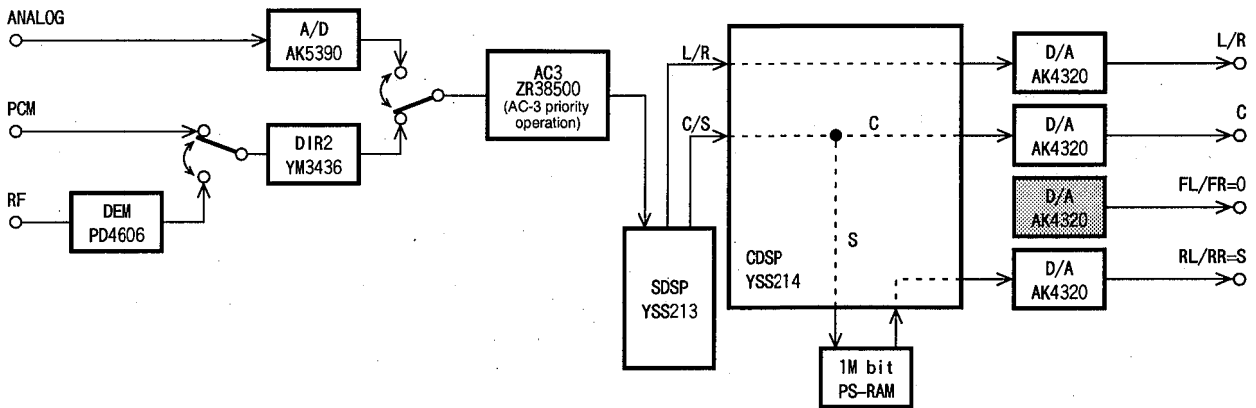

CENTER NORMAL

The center mode uses the normal mode. L, R, C, S signals are pro logic decoded and output.

4. PRO LOGIC
CENTER NORMAL

CENTER WIDE

The center mode uses the wide mode. L, R, C, S signals are pro logic decoded and output.

4. PRO LOGIC
CENTER WIDE

CENTER PHANTOM

The center mode uses the phantom mode. L, R, C, S signals are pro logic decoded and output.

4. PRO LOGIC
CENTER PHANTOM

EFFECT OFF

All DSPs are muted and only the main L/R signal is output through the analog bypass.

4. PRO LOGIC
EFFECT OFF

DSP-A3090

5. SPEAKERS SET

The input L/R signal is output through the specified channels according to the sub-menu.
 (The input data is automatically identified in the priority order of RF → PCM → Analog.)

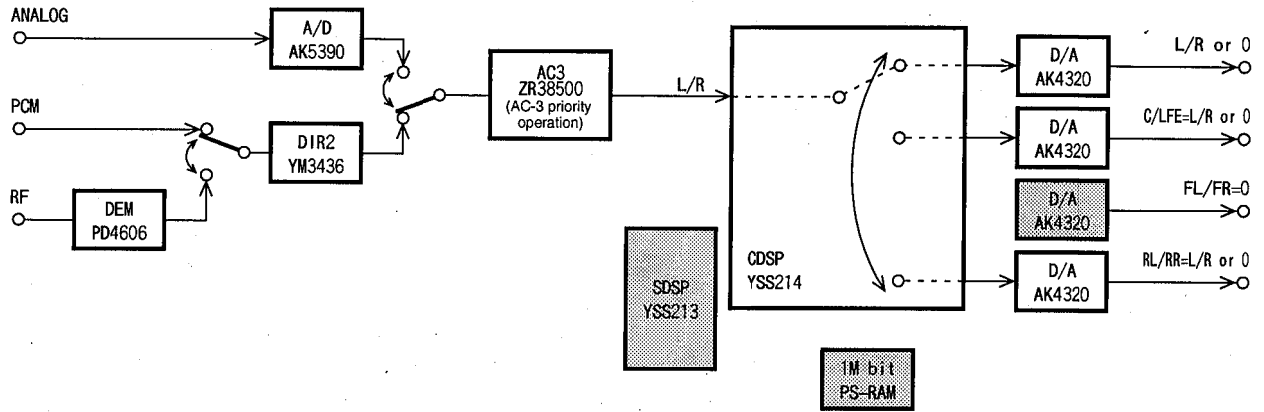

The shaded square means that the element included in it does not operate.

MAIN SP LARGE/SMALL

When LARGE is selected, the input L/R signal is output through the main L/R and when SMALL is selected, only signals lower than 90Hz are mixed in the sub-woofer signal path by using the analog switch.

5. SPEAKERS SET
MAIN SP LARGE

5. SPEAKERS SET
MAIN SP SMALL

REAR SP LARGE/SMALL

When LARGE is selected, the input L/R signal is output through the rear L/R and when SMALL is selected, only signals lower than 90Hz are mixed in the sub-woofer signal path by using the analog switch.

5. SPEAKERS SET
REAR SP LARGE

5. SPEAKERS SET
REAR SP SMALL

LFE BASS SW/MAIN

When SW is selected, the input L/R signal is output through C/LFE (sub-woofer) and when MAIN is selected, only signals lower than 90Hz are mixed in the main L/R signal path by using the analog switch. (No signal is output at the sub-woofer terminal.)

5. SPEAKERS SET
LFE/BASS SW

5. SPEAKERS SET
LFE/BASS MAIN

DSP-A3090

6. ANALOG INPUT

The analog input trim varies as 0dB/+2DB/+4DB according to the sub-menu.
 The input is fixed to the analog mode. All signals are muted in the DSP section and only the main L/R is output through the analog bypass.

INPUT TRIM 0dB/+2dB/+4dB

The input trim varies by 2dB step when operated by using the sub-menu.

```

6. ANALOG INPUT
INPUT TRIM 0dB
    
```

Supplementary information :

The analog input trim (from 0db to +6dB, by 2dB step) is executed by controlling the gain of the operation amplifier with 2 analog switches (L ch : Q1, Q3 / Rch : Q2, Q4) turned ON and OFF. As both of these analog switches are turned ON at +6dB, if normal operation is available at +2dB / +4dB, it is also available at +6dB. Also, as the input is fixed to the analog mode in this menu, RF or PCM signal is not output even when it is inputted.

7. MANUAL TEST

The test noise is output by the noise generator with a built-in DSP through the channels specified by the sub-menu. (The center mode is fixed to the wide mode.)

```

7. MANUAL TEST
ALL
    
```

ALL

Noise is output to all channels.

MAIN L

Noise is output to the MAIN L channel.

CENTER

Noise is output to the CENTER channel.

MAIN R

Noise is output to the MAIN R channel.

REAR R

Noise is output to the REAR R channel.

REAR L

Noise is output to the REAR L channel.

FRONT R

Noise is output to the FRONT R channel.

FRONT L

Noise is output to the FRONT L channel.

LFE

Noise is output to the LFE (sub-woofer) channel.

8. PRESET

This menu reserves and inhibits initialization of the back-up RAM (parameters, set menu contents, etc. for the sound field program)

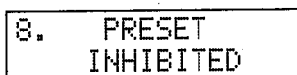

INHIBITED

RAM initialization is not executed. Select INHIBITED when protecting the values set by the user.

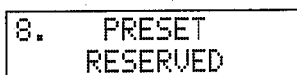

RESERVED

Initialization of the back-up RAM is reserved and it is executed when canceling DIAG. When shipping out of the factory or resetting RAM, select RESERVED.

While this menu is executed, all signals in the DSP section are muted and only the main L/R signal is output through the analog bypass.

9. DISPLAY CHK

This menu checks the FL display section and LED lighting. It is started and stopped by operating the sub-menu. When the program starts, the TAPE2 LED lights and the FL display operates as shown below.

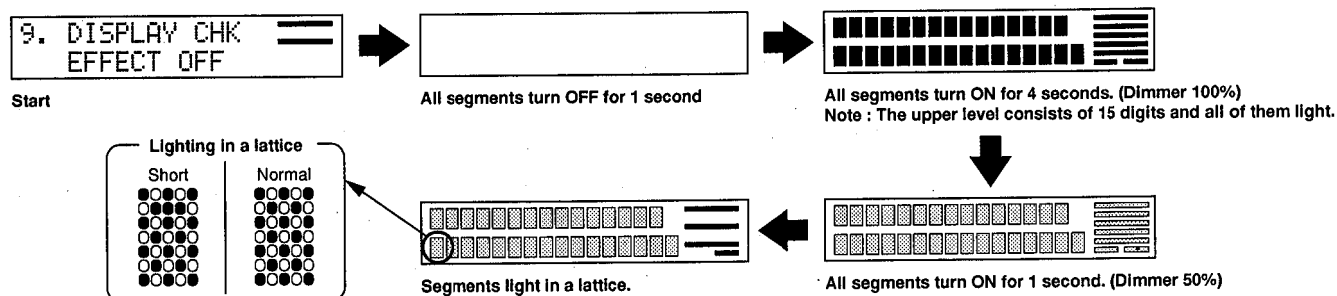

Segment conditions of the FL driver (IC901, IC902) and the FL tube are checked by turning ON and OFF all segments. Next, the operation of the FL driver is checked by using the dimmer control. Then a short between segments next to each other is checked by turning ON and OFF all segments alternately (in a lattice). (In the above example, the center segment in the second row from the top is shorted.)

While this menu is executed, all signals in the DSP section are muted and only the main L/R signal is output through the analog bypass.

10. AD DATA CHK

The A/D conversion value (7ch) of the main CPU (IC1) detecting the input/rec out selector, the main unit key, protection, etc. is divided into 2 pages and displayed in % by using the sub-menu. (5V as 100%)

This menu checks the A/D input port of the main CPU and the resistance value for voltage division. When the protection (PRD/PRV) is out of the normal value, the power turns OFF. Also, other A/Ds fail to operate properly when it is $\pm 4\%$ off from the standard value. In this case, check the constant of the partial pressure resistor, poor soldering, etc.

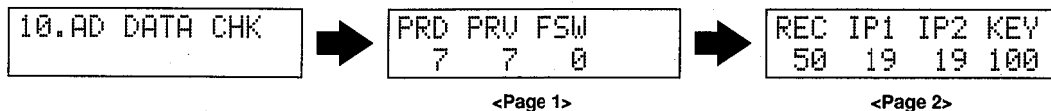

While Pages 1 and 2 are on display, it is possible to use functions of DIAG. menu selection, power OFF and DIAG cancellation only.

Page 1

- PRD : DC detect protection value (Normal value 1 - 13)
- PRV : Power supply voltage protection value (Normal value 2 - 15)
- FSW : Rear panel FRONT MIX switch, PAL/NTSC (R only) detection (20% step)

Standard value of FSW (Rear panel switch)

For R	FRONT MIX		Other than for R	FRONT MIX	
	OFF	ON		OFF	ON
NTSC	0	40		0	40
PAL	20	60			

Page 2

- REC : Value at REC OUT position (10% step)
- IP1 : Value 1 at INPUT SEL position (10% step)
- IP2 : Value 2 at INPUT SEL position (10% step)
- KEY : Detection of main unit panel key operation (10% step)

Standard value of REC OUT position

REC OUT	Standard value
CD	60
SOURCE	50
LD	40
TV/DBS	30
VCR2	20
VCR3/DVD	10
VIDE AUX	0

Standard value of INPUT SEL (input selector) position

INPUT	IP1 standard value	IP2 Standard value
PHONO	0	0
Intermediate position	100	0
CD	10	0
Intermediate position	10	100
TUNER	10	10
Intermediate position	100	10
TAPE1	20	10
Intermediate position	20	100
LD	20	20
Intermediate position	100	20
TV/DBS	30	20
Intermediate position	30	100
VCR3/DVD	30	30
Intermediate position	100	30
VCR1	40	30
Intermediate position	40	100
VCR2	40	40
Intermediate position	100	40
VIDEO AUX	50	40

Standard value of KEY (main unit panel key)

KEY	Standard value
TAPE2 MONITOR	0
INPUT MODE	60
EFFECT	70
PROGRAM +	80
PROGRAM -	90
SET MENU	---
INPUT TRIM +	40
INPUT TRIM -	50
KEY OFF state	100

The contents of signal processing while using the menu is the same as ZR → S → C → PS RAM (p. 12) of DIAG menu 2. DSP RAM THR.

DSP-A3090

11. VERSION CHK

In this menu, versions of CPU (Main/Sub) and ZR38500 are displayed alternately. When replacing the CPU, be sure to check the version of the CPU. The CPU may not be suitable depending on its compatibility. Using an unsuitable CPU will prevent normal communication between CPUs.

When the version display of the CPU and ZR is other than those shown below, possibility is as follows.

- 1) Failure in communication between CPUs using a flat connecting cable or connector.
(Communication failure can be checked also by using DIAG menu No.12.)
- 2) Malfunction of the sub-CPU due to clock, power supply or resetting.

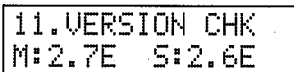

MAIN VERSION, SUB VERSION

M : stands for Main CPU (IC1) and S : for Sub-CPU (IC17). The number indicates the CPU version and the alphabet compatibility with each other. Compatibility of the CPU is indicated by using 2 or less alphabets. Even when the numbers do not match, if the same alphabet is included, they are compatible. (For example, "EF" means that it is compatible with both "E" and "F" versions of the other CPU.)

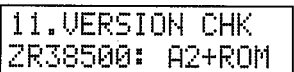

ZR38500 VERSION

ZR : stands for versions (4 types) of ZR38500.
 A2+ROM : Normal operation (See pages 56, 73)
 A3 : Normal operation
 A0-A2 : Check SRAM (IC14 - 16, 43) or the external ROM (IC44) for failure.
 ILLEGAL : It is possible that ZR38500 or the external ROM (IC44) is faulty.

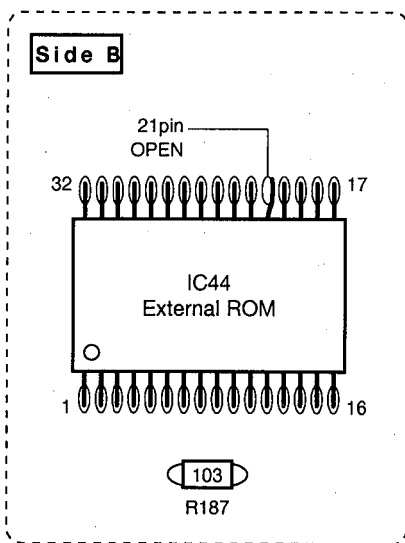

To check the external ROM (IC44) for failure when "ILLEGAL" was displayed

- 1) Loosen No. 21 pin of the external ROM (IC44) located on the DSP circuit board (Side B) and add a 10kΩ resistor to R187. (This will enable ZR38500 to operate without the external ROM.)
- 2) Check the ZR version again.
- 3) When "A0-A2" is displayed, the interface between the sub-CPU and ZR38500, ZR resetting, etc. are normal. (The sound will be muted.) Check SRAM (IC14 - 16, 43) of the DSP circuit board (Side A) or the external ROM (IC44) for faulty condition (including poor soldering and a faulty pattern).
- 4) If "ILLEGAL" is displayed again, it is highly possible that ZR38500 is faulty.

IC43(SRAM) and IC44(external ROM) are used up to the A2 version of ZR38500. As the A3 version does not require IC43 or IC44, there will be no such faulty factor caused by them.

The signals in the DSP section are all muted while this menu is executed and only the main L/R is output through the analog bypass.

12. EXIT

The lower line indicates the operation condition (in binary numeral).

The self-diagnosis function is completed by using the sub-menu and the normal operation is restored.

The contents of the signal process while using the menu are the same as the menu used before executing this menu.

```

12.  EXIT
00101011 1111
bit 7 6 5 4 3 2 1 0   3 2 1 0
    First data   Second data
    
```

The first data indicates the operation condition of DIR (IC21) and the digital system in the binary numeral (8 bits).

The second data indicates the communication condition between the main CPU and sub-CPU in the binary numeral (4 bits).

First data

- bit 7 : "1" at the digital mute ON/OFF and during digital muting
- bit 6 : Data transmission from the main CPU to the sub-CPU is required. "1" at start and communication error.
- bit 5 : MUTO terminal of DEM (PD4606) is detected. "1" when no signal is applied to AC-3RF and a DEM error occurred.
- bit 4 : "1" when the channel number (front/rear) of the AC-3 source is 1/0, 2/1, 2/2, 3/0, 3/1 or 3/2.
- bit 3 : "1" when ZR38500 is decoding the AC-3 signal properly.
- bit 2 : "1" when the digital source is PCM AUDIO and "0" when it is DAT (AC-3, CD-ROM).
- bit1, 0 : Sample frequency information ("00" : 32k/"01" : 44.1k/"10" : 48k/"11" : analog)

Second data

- bit 3 : Communication request (MRQ) from the main CPU to the sub-CPU. "0" while requesting.
- bit 2 : Communication data from the main CPU to the sub-CPU (MTS)
- bit 1 : Communication data from the sub-CPU to the main CPU (STM).
- bit 0 : Communication request from the sub-CPU to the main CPU (SRQ). "0" while requesting.

As communication between the main CPU and the sub-CPU usually takes place periodically or when some operation is done, the display changes as in "1111" → "1110" → "1111". When the display is fixed without any change, however, it is possible that a communication hang-up has occurred. In such case, check the flat connecting cable for poor insertion and the connector for poor soldering.

Example of normal operation during AC-3 reproduction
 AC-3 RF input and source channel number 3/2
 fs : 48kHz source is reproduced

```

12.  EXIT
00011010 1111
    
```

Example of normal operation during analog reproduction
 Analog input or no signal applied

```

12.  EXIT
00000111 1111
    
```

Example of normal operation during PCM reproduction
 fs: 44.1kHz PCM audio is reproduced.

```

12.  EXIT
00000101 1111
    
```

■ TEST POINT WAVEFORMS

Point ① (Pin 17 of IC 1)

V : 2V/div H : 50nsec/div DC range 1 : 1 probe

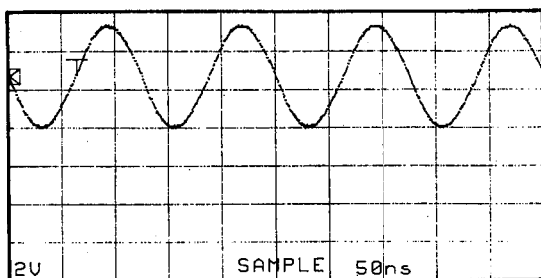

Point ⑤ (Pin 13 of IC 21)

V : 2V/div H : 50nsec/div DC range 1 : 1 probe

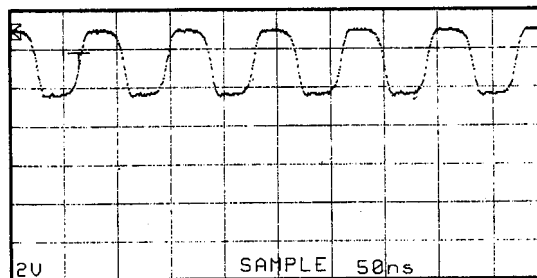

Point ②

(CH1 : Emitter of Q6) V : 10V/div (CH1)
(CH2 : Collector of Q7) V : 2V/div (CH2)

H : 0.5 sec/div DC range 1 : 1 probe
(This waveform is not available by pushing the power switch ON and OFF.)

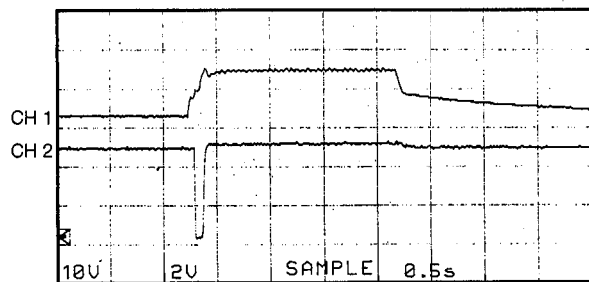

With the POWER switch turned ON, connect the power cord to the AC outlet.

Disconnect the power cord from the AC outlet.

Point ⑥ (Pin 82 of IC 13)

V : 2V/div H : 50nsec/div DC range 1 : 1 probe

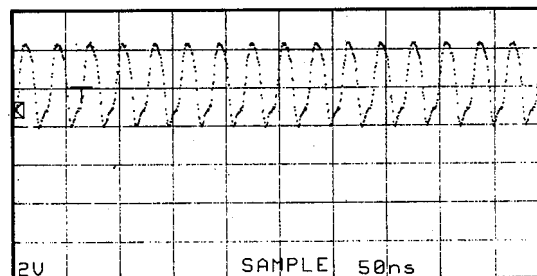

Point ③ (Pin 11 of IC 10)

V : 2V/div H : 50nsec/div DC range 1 : 1 probe

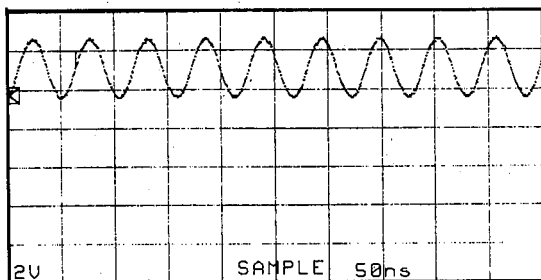

Point ⑦ (Pin 9 of IC17)

V : 2V/div H : 50nsec/div DC range 1 : 1 probe

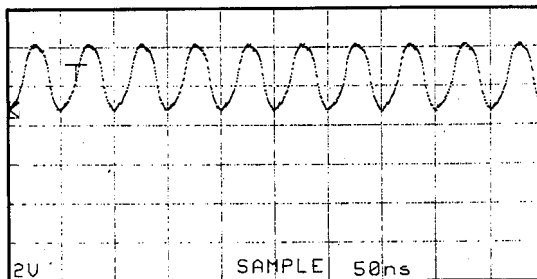

Point ④ (Pin 3 of IC 11)

V : 2V/div H : 50nsec/div DC range 1 : 1 probe

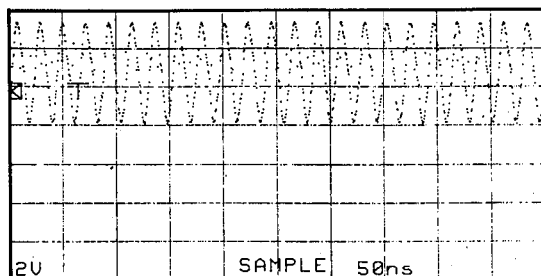

Point ⑧ (Pin 16 of IC 12)

V : 2V/div H : 50nsec/div DC range 1 : 1 probe

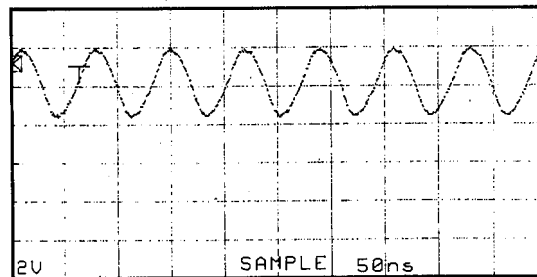

DSP-A3090

■ IC DATA

IC11 : PD4606A
AC-3 RF Demodulator

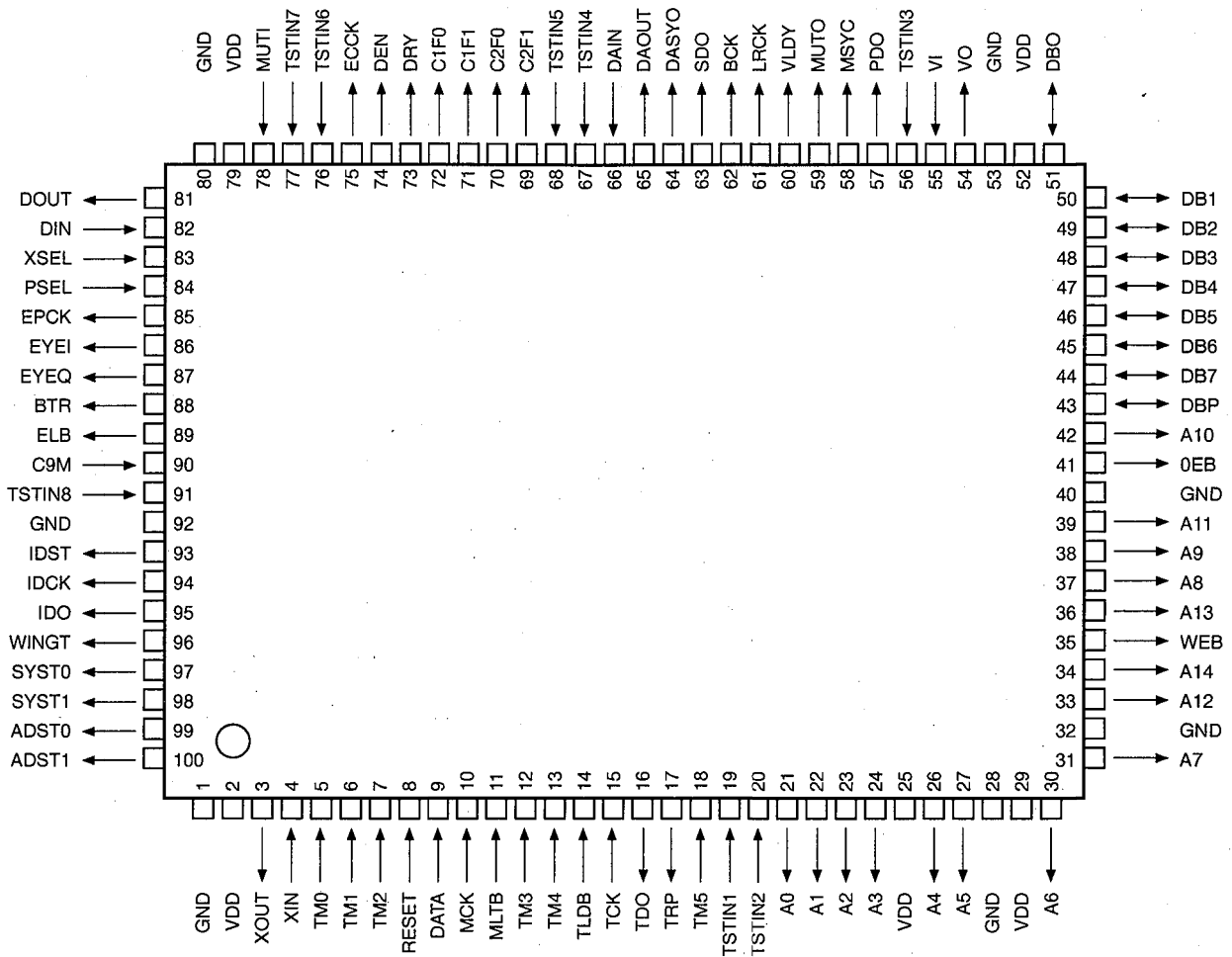

DSP-A3090

No.	Name	I/O	Function
1	GND	—	Ground (0V)
2	VDD	—	+5V power supply.
3	XOUT	O	Crystal oscillation circuit output.
4	XIN	I	Crystal oscillation circuit input.
5	TM0	I	Terminal for setting IC test mode, normally unconnected.
6	TM1	I	Terminal for setting IC test mode, normally unconnected.
7	TM2	I	Terminal for setting IC test mode, normally unconnected.
8	RESET	I	System resetting terminal, reset at "L". Set to "L" once when turning ON the power.
9	DATA	I	Serial data input from CPU (LSB first).
10	MCK	I	CPU serial input clock, data is latched at the rise edge of clock.
11	MLTB	I	CPU input latch, serial data (for 8 bits) from CPU is latched to register.
12	TM3	I	Terminal for setting IC test mode, normally unconnected.
13	TM4	I	Terminal for setting IC test mode, normally unconnected.
14	TLDB	I	Tag code load signal, tag code is loaded to 16-bit shift register at "L".
15	TCK	I	Clock for tag code output, data is output at the rise edge of clock.

IC11 : PD4606A
AC-3 RF Demodulator

No.	Name	I/O	Function
16	TDO	O	Tag code serial data output (MSB first).
17	TRP	O	Tag code renewing signal, setting becomes "H" if tag code has no error when correction for 1 block is over.
18	TMS	I	Terminal for setting IC test mode, normally unconnected.
19	TSTIN1	I	IC test terminal, normally unconnected.
20	TSTIN2	I	IC test terminal, normally unconnected.
21	A0	O	External RAM address output. Address 0 (LSB)
22	A1	O	External RAM address output. Address 1
23	A2	O	External RAM address output. Address 2
24	A3	O	External RAM address output. Address 3
25	VDD	—	+5V power supply.
26	A4	O	External RAM address output. Address 4
27	A5	O	External RAM address output. Address 5
28	GND	—	Ground (0V)
29	VDD	—	+5V power supply.
30	A6	O	External RAM address output. Address 6
31	A7	O	External RAM address output. Address 7
32	GND	—	Ground (0V)
33	A12	O	External RAM address output. Address 12
34	A14	O	External RAM address output. Address 12 (MSB)
35	WEB	O	External RAM write enable signal, "L" Active
36	A13	O	External RAM address output. Address 13
37	A8	O	External RAM address output. Address 8
38	A9	O	External RAM address output. Address 9
39	A11	O	External RAM address output. Address 11
40	GND	—	Ground (0V)
41	OEB	O	External RAM output enable signal. "L" active.
42	A10	O	External RAM address output. Address 10.
43	DBP	I/O	External RAM data terminal. Eraser pointer terminal.
44	DB7	I/O	External RAM data terminal. Data bus 7
45	DB6	I/O	External RAM data terminal. Data bus 6
46	DB5	I/O	External RAM data terminal. Data bus 5
47	DB4	I/O	External RAM data terminal. Data bus 4
48	DB3	I/O	External RAM data terminal. Data bus 3
49	DB2	I/O	External RAM data terminal. Data bus 2
50	DB1	I/O	External RAM data terminal. Data bus 1
51	DB0	I/O	External RAM data terminal. Data bus 0
52	VDD	—	+5V power supply.
53	GND	—	Ground (0V)
54	VO	L	VCXO output.
55	VI	I	VCXO input.
56	TSTIN3	I	IC test terminal, normally unconnected.
57	PDO	O	Phase comparator output (tri-state)
58	MSYC	O	"H" at AC-3 synchronous signal. Monitor terminal
59	MUTO	O	Muting output. Muting available at "H". Setting becomes "H" when "MUTI=H" or AC-3 is asynchronous.
60	VLDY	O	Validity flag output. Correct data at "L". Possibly incorrect at "H"
61	LRCK	O	L/R channel switching clock. 48kHz. L channel at "H".
62	BCK	O	Bit clock, 3.072MHz.
63	SDO	O	Serial data output.
64	DASYO	O	Digital out preamble B identification signal.

IC11 : PD4606A
AC-3 RF Demodulator

No.	Name	I/O	Function
65	DAOUT	O	Digital out output.
66	DAIN	I	Digital audio interface signal input. Signal from digital out terminal or "DAIN" after being processed in IC is selected and output at "DAOUT".
67	TSTIN4	I	IC test terminal, normally unconnected.
68	TSTIN5	I	IC test terminal, normally unconnected.
69	C2F1	O	Terminal used to indicate error condition after C2 correction, whether completely corrected or not.
70	C2F0	O	Terminal used to indicate error condition after C2 correction, number of errors at C2.
71	C1F1	O	Terminal used to indicate error condition after C1 correction, whether any error exists or not.
72	C1F0	O	Terminal used to indicate error condition after C1 correction, number of errors at C1.
73	DRY	O	Monitor terminal for error correction section.
74	DEN	O	Monitor terminal for error correction section.
75	ECK	O	Clock for error correction section, 576KHz.
76	TSTIN6	I	IC test terminal, normally unconnected.
77	TSTIN7	I	IC test terminal, normally unconnected.
78	MUTI	I	Muting input. Muting available at "H".
79	VDD	—	+5V power supply.
80	GND	—	Ground (0V)
81	DOUT	O	QPSK inverted output.
82	DIN	I	QPSK signal input.
83	XSEL	I	Crystal select, used at "H".
84	PSEL	I	PLL select, used at "L".
85	EPCK	O	Clock for QPSK eye pattern, 288KHz.
86	EYEI	O	Eye pattern output : I phase.
87	EYEQ	O	Eye pattern output : Q phase.
88	BTR	O	
89	ELB	O	
90	C9M	O	9.216MHz
91	TSTIN8	I	IC test terminal, normally unconnected.
92	GND	—	Ground (0V)
93	IDST	O	Signal to indicate ID start position.
94	IDCK	O	ID signal sample clock. Data changes at the fall edge of clock, 576KHz.
95	IDO	O	ID data output (MSB first).
96	WINGT	O	Setting becomes "L" while searching synchronous signal of correction block.
97	SYST0	O	Terminal used to indicate lock condition of synchronous signal in correction block.
98	SYST1	O	Terminal used to indicate lock condition of synchronous signal in correction block.
99	ADST0	O	Terminal used to indicate continuity condition of ID address in correction block.
100	ADST1	O	Terminal used to indicate continuity condition of ID address in correction block.

IC21 : YM3436DK
DIR (Digital Format Interface Receiver)

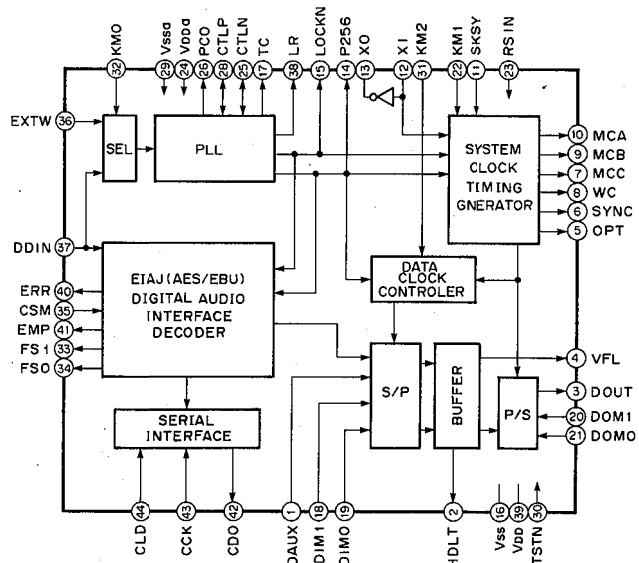
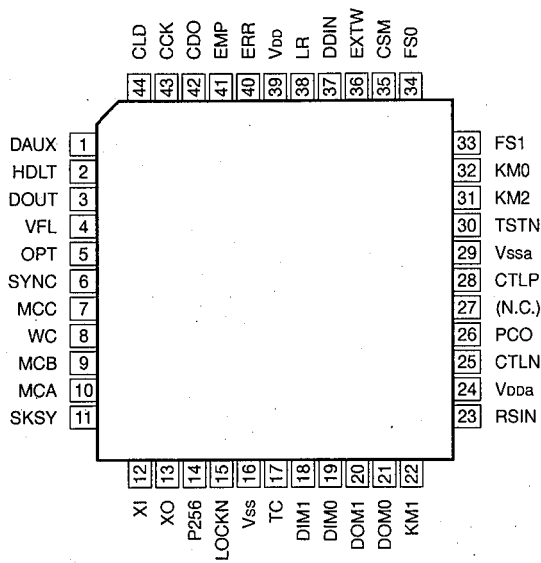

Pin No.	Pin Name	I/O	Function	Pin No.	Pin Name	I/O	Function
1	DAUX	I	Auxiliary input for audio data	26	PCO	O	PLL phase comparison output
2	HDLT	O	Asynchronous buffer operation flag	27	(NC)		
3	DOUT	O	Audio data output	28	CTLP	I	VCO control input P
4	VFL	O	Parity flag output	29	Vssa		VCO section power (GND)
5	OPT	O	Fs x 1 Synchronous output signal for DAC	30	TSTN	I	Test terminal. Open for normal use
6	SYNC	O	Fs x 1 Synchronous output signal for DSP	31	KM2	I	Clock mode switching input 2
7	MCC	O	Fs x 64Bit clock output	32	KM0	I	Clock mode switching input 0
8	WC	O	Fs x 1Word clock output	33	FS1	O	Channel status sampling frequency display output 1
9	MCB	O	Fs x 128Bit clock output	34	FS0	O	Channel status sampling frequency display output 0
10	MCA	O	Fs x 256Bit clock output	35	CSM	I	Channel status output method selection
11	SKSY	I	Clock synchronization control input	36	EXTW	I	External synchronous auxiliary input word clock
12	XI	I	Crystal oscillator connection or external clock input	37	DDIN	I	EIAJ (AES/EBU) data input
13	XO	O	Crystal oscillator connection	38	LR	O	PLL word clock output
14	P256	O	VCO oscillating clock connection	39	Vdd		Logic section power (+5V)
15	LOCK	O	PLL lock flag	40	ERR	O	Data error flag output
16	Vss		Logic section power (GND)	41	EMP	O	Channel status emphasis control code output
17	TC	O	PLL time constant switching output	42	CDO	O	3-wire type microcomputer interface data output
18	DIM1	I	Data input mode selection	43	CCK	I	3-wire type microcomputer interface clock input
19	DIM0	I	Data input mode selection	44	CLD	I	3-wire type microcomputer interface load input
20	DOM1	I	Data output mode selection				
21	DOM0	I	Data output mode selection				
22	KM1	I	Clock mode switching input 1				
23	RSTN	I	System reset input				
24	Vdda		VCO section power (+5V)				
25	CTLN	I	VCO control input N				

DSP-A3090

IC41 : YSS213-K
Dolby-Pro-Logic Decoder +LDSP (SDSP)

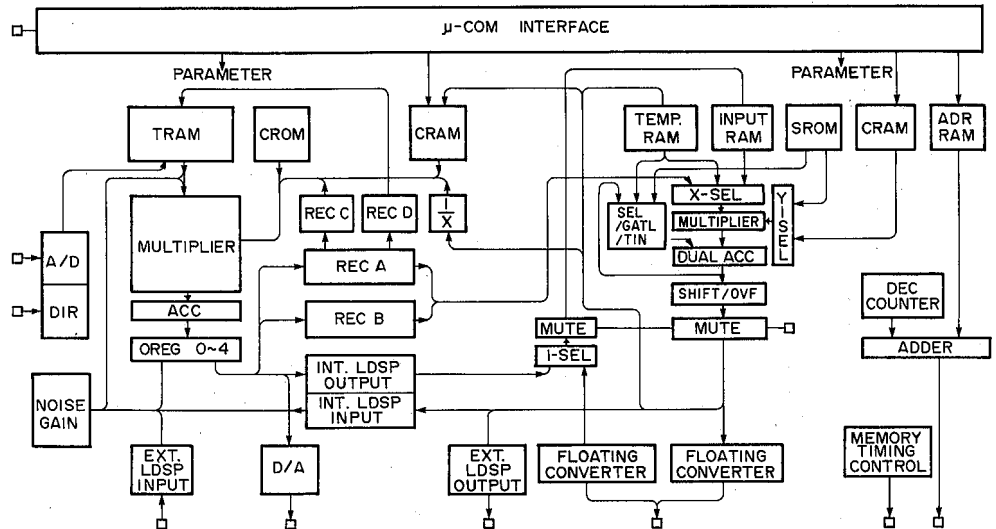
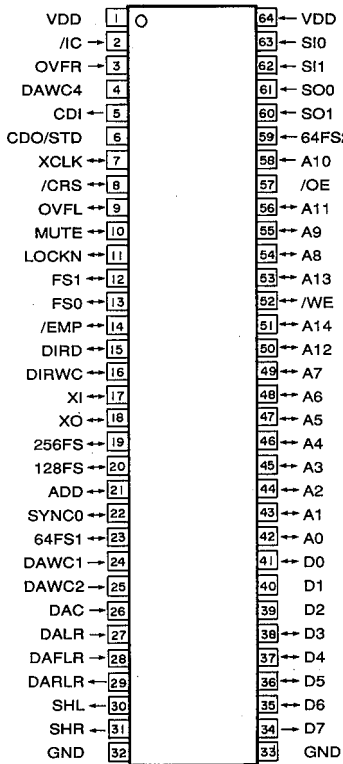

- The Dolby Pro Logic section has bi-directional emphasis circuit, noise sequencer, 7kHz low pass filter(variable), transformed B-type N.R. decoder, center mode control, automatic input balance and automatic phase control all built in.
- The front 3 channels have 5 bands of secondary IIR equalizer for the tone correction built in, 3 bands at the center and 1 band each at the right and left.
- The sampling frequency can be switched automatically among 32kHz, 44.1kHz and 48kHz. (It can also be fixed.)

No.	Name	I/O	Function
1	VDD	—	+5V power supply
2	IC	Ics	Initial clear input
3	OVFR	O	Rch input, Overflow detect terminal
4	DAWC4	O	L/R word clock for D/A converter (18 bit output)
5	CDI	I _{ts}	Microprocessor interface data input
6	CDO/STD	O	Microprocessor interface data output
7	XCLK	I _{ts}	Microprocessor interface clock input
8	CRS	I _{ts}	Microprocessor interface reset terminal
9	OVFL	O	Lch input overflow detect terminal
10	MUTE	O	System mute detect terminal
11	LOCKN	I _{ts}	DIR2 Lock detect terminal
12	FS1	I _{ts}	Sampling frequency select terminal
13	FS0	I _{ts}	Sampling frequency select terminal
14	EMP	I _{ts}	De-emphasis select terminal
15	DIRD	I _t	DIR2 data input
16	DIRWC	I _{ts}	DIR2 word clock input
17	XI	I _c	Crystal oscillation input terminal
18	XO	O	Crystal oscillation output terminal

IC41 : YSS213-K
Dolby-Pro-Logic Decoder +LDSP (SDSP)

No.	Name	I/O	Function
19	256FS	O	256*FS clock output
20	128FS	O	128*FS clock output
21	ADD	It	A/D converter data input terminal
22	SYNCO	O	External LDSP system synchronous signal A/D converter word clock
23	64FS1	O	64*FS clock (for A/D, D/A converter)
24	DAWC1	O	D/A conversion clock (16 bit output)
25	DAWC2	O	D/A converter L/R word clock (16 bit output)
26	DAC	O	Center main channel D/A converter output
27	DALR	O	L, R main channel D/A converter output
28	DAFLR	O	Front L, R surround channel D/A converter output
29	DARLR	O	Rear L, R surround channel D/A converter output
30	SHL	O	D/A converter L channel sample/hold signal
31	SHR	O	D/A converter R channel sample/hold signal
32	GND	—	Ground
33	GND	—	Ground
34	D7	It/O	External delay PSRAM data terminal
35	D6	It/O	External delay PSRAM data terminal
36	D5	It/O	External delay PSRAM data terminal
37	D4	It/O	External delay PSRAM data terminal
38	D3	It/O	External delay PSRAM data terminal
39	D2	It/O	External delay PSRAM data terminal
40	D1	It/O	External delay PSRAM data terminal
41	D0	It/O	External delay PSRAM data terminal
42	A0	O	External delay PSRAM address terminal
43	A1	O	External delay PSRAM address terminal
44	A2	O	External delay PSRAM address terminal
45	A3	O	External delay PSRAM address terminal
46	A4	O	External delay PSRAM address terminal
47	A5	O	External delay PSRAM address terminal
48	A6	O	External delay PSRAM address terminal
49	A7	O	External delay PSRAM address terminal
50	A12	O	External delay PSRAM address terminal
51	A14	O	External delay PSRAM address terminal
52	\overline{WE}	O	External delay PSRAM write enable terminal
53	A13	O	External delay PSRAM address terminal
54	A8	O	External delay PSRAM address terminal
55	A9	O	External delay PSRAM address terminal
56	A11	O	External delay PSRAM address terminal
57	\overline{OE}	O	External delay PSRAM output enable terminal
58	A10	O	External delay PSRAM address terminal
59	64FS2	O	64*FS clock (/CE and LDSP master clock of PSRAM)
60	SO1	O	LDSP serial tone data output 1 channel
61	SO0	O	LDSP serial tone data output 0 channel
62	SI1	It	LDSP serial tone data input 1 channel
63	SI0	It	LDSP serial tone data input 0 channel
64	VDD	—	+5V power supply

Note) Symbols used in the I/O column mean as follows.

I : Input terminal O : Output terminal
t : TTL level c : CMOS level
s : Shmidt input

IC18 : YSS214
CDSP

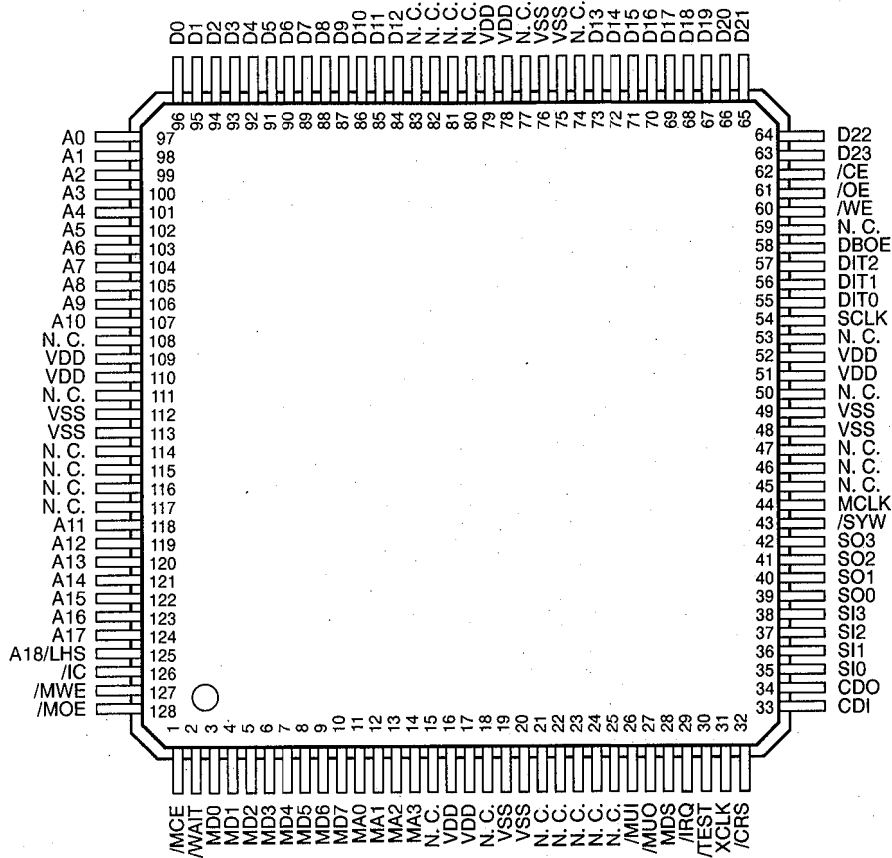

No.	Name	I/O	Function
1	/MCE	Is+	Chip enable input from CPU
2	/WAIT	OD	Wait signal output to CPU
3	MD0	Is/O	CPU I/F parallel data
4	MD1	Is/O	CPU I/F parallel data
5	MD2	Is/O	CPU I/F parallel data
6	MD3	Is/O	CPU I/F parallel data
7	MD4	Is/O	CPU I/F parallel data
8	MD5	Is/O	CPU I/F parallel data
9	MD6	Is/O	CPU I/F parallel data
10	MD7	Is/O	CPU I/F parallel data
11	MA0	Is	CPU I/F address input
12	MA1	Is	CPU I/F address input
13	MA2	Is	CPU I/F address input
14	MA3	Is	CPU I/F address input
15	N.C.	-	Unconnected
16	VDD	-	+5V power supply
17	VDD	-	+5V power supply
18	N.C.	-	Unconnected
19	VSS	-	Ground
20	VSS	-	Ground
21	N.C.	-	Unconnected
22	N.C.	-	Unconnected
23	N.C.	-	Unconnected
24	N.C.	-	Unconnected

DSP-A3090

IC18 : YSS214
CDSP

No.	Name	I/O	Function
25	N.C.	-	Unconnected
26	/MUI	Is+	Serial data input gate
27	/MUO	O	Serial data output mute
28	MDS	Is+	Micro-processor communication mode select
29	/IRQ	OD	Interrupt request
30	/TEST	Is+	LSI test (normally unconnected)
31	XCLK	Is/O	Serial control data shift clock
32	/CRS	Is+/O	Reset signal for serial control data synchronization
33	CDI	Is+	Serial control data input
34	CDO	O	Serial control data output
35	SI0	Is+	Serial data input
36	SI1	Is+	Serial data input
37	SI2	Is+	Serial data input
38	SI3	Is+	Serial data input
39	SO0	O	Serial data output
40	SO1	O	Serial data output
41	SO2	O	Serial data output
42	SO3	O	Serial data output
43	/SYW	Is	Signal input for system synchronization
44	MCLK	Is	Master clock input (256fs)
45	N.C.	-	Unconnected
46	N.C.	-	Unconnected
47	N.C.	-	Unconnected
48	VSS	-	Ground
49	VSS	-	Ground
50	N.C.	-	Unconnected
51	VDD	-	+5V power supply
52	VDD	-	+5V power supply
53	N.C.	-	Unconnected
54	SCLK	O	Clock output (64fs)
55	DIT0	O	Digital audio interface data output
56	DIT1	O	Digital audio interface data output
57	DIT2	O	Digital audio interface data output
58	DBOE	Is+	memory data bus output enable
59	N.C.	-	Unconnected
60	/WE	O	External RAM write enable
61	/OE	O	External RAM output enable
62	/CE	O	External RAM chip enable
63	D23	Is+/O	External RAM data
64	D22	Is+/O	External RAM data
65	D21	Is+/O	External RAM data
66	D20	Is+/O	External RAM data
67	D19	Is+/O	External RAM data
68	D18	Is+/O	External RAM data
69	D17	Is+/O	External RAM data
70	D16	Is+/O	External RAM data
71	D15	Is+/O	External RAM data
72	D14	Is+/O	External RAM data
73	D13	Is+/O	External RAM data
74	N.C.	-	Unconnected
75	VSS	-	Ground
76	VSS	-	Ground

IC18 : YSS214
CDSP

No.	NAME	I/O	FUNCTION
77	N.C.	-	Unconnected
78	VDD	-	+5V power supply
79	VDD	-	+5V power supply
80	N.C.	-	Unconnected
81	N.C.	-	Unconnected
82	N.C.	-	Unconnected
83	N.C.	-	Unconnected
84	D12	Is+O	External RAM data
85	D11	Is+O	External RAM data
86	D10	Is+O	External RAM data
87	D9	Is+O	External RAM data
88	D8	Is+O	External RAM data
89	D7	Is+O	External RAM data
90	D6	Is+O	External RAM data
91	D5	Is+O	External RAM data
92	D4	Is+O	External RAM data
93	D3	Is+O	External RAM data
94	D2	Is+O	External RAM data
95	D1	Is+O	External RAM data
96	D0	Is+O	External RAM data
97	A0	O	External RAM address
98	A1	O	External RAM address
99	A2	O	External RAM address
100	A3	O	External RAM address
101	A4	O	External RAM address
102	A5	O	External RAM address
103	A6	O	External RAM address
104	A7	O	External RAM address
105	A8	O	External RAM address
106	A9	O	External RAM address
107	A10	O	External RAM address
108	N.C.	-	Unconnected
109	VDD	-	+5V power supply
110	VDD	-	+5V power supply
111	N.C.	-	Unconnected
112	VSS	-	Ground
113	VSS	-	Ground
114	N.C.	-	Unconnected
115	N.C.	-	Unconnected
116	N.C.	-	Unconnected
117	N.C.	-	Unconnected
118	A11	O	External RAM address
119	A12	O	External RAM address
120	A13	O	External RAM address
121	A14	O	External RAM address
122	A15	O	External RAM address
123	A16	O	External RAM address
124	A17	O	External RAM address
125	A18/LHS	O	External RAM address/L/H word clock
126	/IC	Is	Initial clear
127	/MWE	Is+	Write enable input from CPU
128	/MOE	Is+	Output enable input from CPU

I: Input O: Output +: Built-in pull-up resistor s: Schmitt input
 OD: Open drain N.C.: Non-connect (unconnected)

IC12 : M35010-062SP
Super Impose

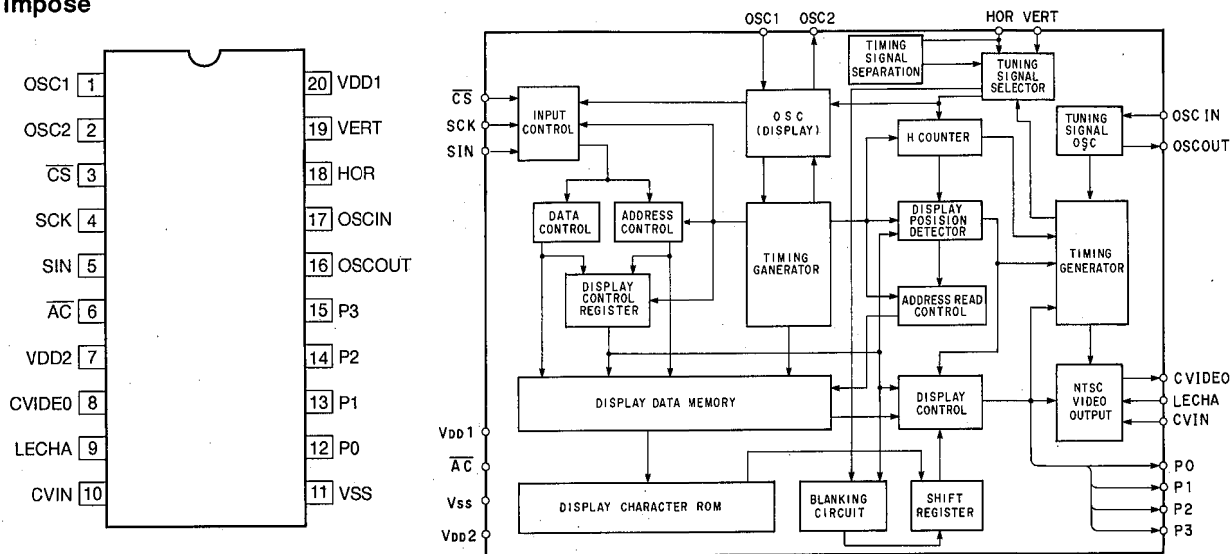

Pin No.	Symbol	Terminal name	Function
1	OSC1	External terminal for oscillation circuit	External terminal of oscillation circuit for display. The standard oscillation frequency is about 7MHz. The display position in the horizontal direction and width of characters on the TV screen are determined according to this oscillation frequency.
2	OSC2	External terminal for oscillation circuit	
3	CS	Chip select input	Chip select terminal "L" is set when the serial data is transferred. Hysteresis input. A pull-up resistor is built in.
4	SCK	Serial clock input	When CS terminal is "L", the SIN serial data is taken in at the SCK rise. Hysteresis input. A pull-up resistor is built in.
5	SIN	Serial data input	The data and addresses for the display control register and display data memory are inputted in the serial form. Hysteresis input. A pull-up resistor is built in.
6	AC	Auto clear input	The IC internal circuit is reset when in "L" state. Hysteresis input. A pull-up resistor is built in.
7	VDD2	Power supply terminal	Analog type power supply terminal that should be connected to +5V.
8	CVIDEO	Composite video signal output	Output terminal for composite video signal 2Vp-p composite video signal is output. When making a superimposition, the character output and other features are superimposed on the composite video signals inputted through the CVIN terminal.
9	LECHA	Character level input	Input terminal to determine the output level for the characters in the composite video signals. The color of characters is white.
10	CVIN	Video input	Input terminal for external composite video signals. When making a superimposition, the character output and other features are superimposed on these composite video signals.
11	VSS	Ground terminal	Connection to GND is made by using this terminal.
12	P0	Port 0 output	Port terminal output or character background signals (BLNK1*) are output. The polarity can be selected when determining the font ROM.
13	P1	Port 1 output	Port terminal output or character background signals (CO1*) are output. The polarity can be selected when determining the font ROM.
14	P2	Port 2 output	Port terminal output or character background signals (BLNK2*) are output. The polarity can be selected when determining the font ROM.
15	P3	Port 3 output	Port terminal output or character background signals (CO2*) are output. The polarity can be selected when determining the font ROM.
16	OSCOUT	Oscillation circuit for generation of synchronous signals	External terminal of the oscillation circuit for generation of synchronous signals. The oscillation frequency is 14.32MHz when the NTSC system is used and 17.73MHz when the PAL system is used.
17	OSCIN		
18	HOR*	Horizontal synchronous signal input	Horizontal synchronous signals are inputted. Hysteresis input The polarity can be selected when determining the font ROM.
19	VERT*	Vertical synchronous signal input	Vertical synchronous signals are inputted. Hysteresis input The polarity can be selected when determining the font ROM.
20	VDD1	Power supply terminal	Digital type power supply terminal that should be connected to +5V.

DSP-A3090

IC1 : HD6473614P
8 bit μ -COM (Main CPU)

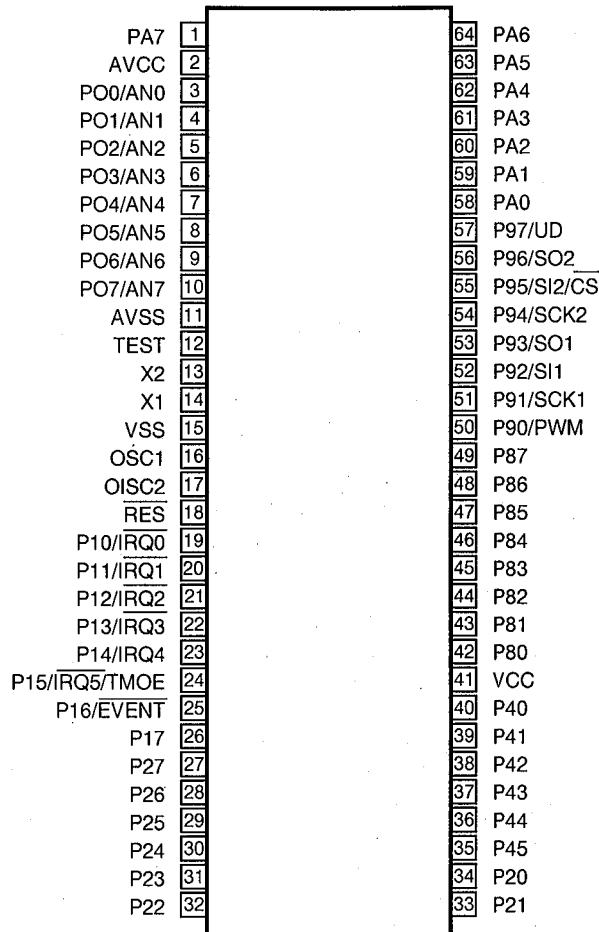

DSP-A3090

No.	PORT	NAME	I/O	FUNCTION	POWER ON	POWER OFF	BACKUP
1	PA7	/HMT	O	HEAD PHONE MUTE	O	OL	OL
2	AVCC	AVCC	I	+5V for AD			
3	AN0	REC	I	REC OUT SELECTOR	I	I	I
4	AN1	ADP1	I	AD : INPUT SELECTOR POSITION	I	I	I
5	AN2	ADP2	I	AD : INPUT SELECTOR POSITION	I	I	I
6	AN3	KEY	I	AD : KEY SCAN	I	I	I
7	AN4	PRV	I	AD : PSV PROTECTION	I	I	I
8	AN5	PRD	I	AD : DC PROTECTION	I	I	I
9	AN6	FSW	I	AD : FUNCTION SW	I	I	I
10	P07		I	GND	I	I	I
11	AVSS	AVSS	I	GND for AD			
12	TEST	TEST	I	Vss			
13	X2	X2		OPEN			
14	X1	X1	I	Vcc			
15	VSS	VSS	I	GND for SYSTEM			
16	OSC1	OSC1	I	8MHz			
17	OSC2	OSC2	O	8MHz			
18	RES	/RES	I	RESET			
19	IRQ0	PDT	I	IRQ : POWER DETECT	I	I	I
20	IRQ1	REM	I	IRQ : REMOCON INT.	I	I	I

IC1 : HD6473614P
8 bit μ -COM (Main CPU)

No.	PORT	NAME	I/O	FUNCTION	POWER ON	POWER OFF	BACKUP
21	IRQ2	SRQ	I	IRQ : INPUT STROBE INT.	I	I	I
22	IRQ3	VSY	I	IRQ : SPI V-SYNC DETECT	I	I	I
23	P14/IRQ4			Not used	OL		
24	P15/IRQ5			Not used	OL		
25	P16	EX/AT	I	SPI : FIEXD / AUTO (H / L)	I	I	I
26	P17	INP/N	I	SPI : PAL / NTSC (H / L)	I	I	I
27	P27			Not used	OL		
28	P26			Not used	OL		
29	P25			Not used	OL		
30	P24			Not used	OL		
31	P23			Not used	OL		
32	P22			Not used	OL		
33	P21	E/I	O	VIDEO SYNC	O	OL	OL
34	P20	SRY	O	SP RELAY	O	OL	OL
35	P45	PRY	O	POWER RELAY	O	OL	OL
36	P44	/FMT	O	FULL MUTE	O	OL	OL
37	P43	PRI	I	I PROTECTION	I : OL	I : OL	I : OL
38	P42			Not used	OH	OH	OH
39	P41	VIND	O	VOLUME LED	O	OL	OL
40	P40	PCTL	O	ZR VCC (+5V) PORT	O	OL	OL
41	VCC	VCC	I	+5V for SYSTEM			
42	P80	VDN	O	VOLUME DOWN CONTROL	O	OL	OL
43	P81	VUP	O	VOLUME UP CONTROL	O	OL	OL
44	P82	TR	O	INPUT SELECTOR RIGHT CONTROL	O	OL	OL
45	P83	TL	O	INPUT SELECTOR LEFT CONTROL	O	OL	OL
46	P84	POS	I	INPUT SELECTOR POSISION	I	I	I
47	P85	CES	O	CE : M35010	O	OL	OL
48	P86	CET1	O	CE : TC9162AN	O	OL	OL
49	P87	CET2	O	CE : TC9273N / TC9162AN	O	OL	OL
50	P90	CEL1	O	CE : LC7535 / LC7824 / LC75710	O	OL	OL
51	SCK1	SCK	O	SERIAL CLOCK	O	OL	OL
52	P92	CEL2	O	CE : LC7535 / LC782132 / LC75710	O	OL	OL
53	SO1	SDT	O	SERIAL DATA	O	OL	O
54	SKC2	CLK	O	COM : CLOCK	O	OL	OL
55	SI2	STM	I	COM : RXD	I	I	I
56	SO2	MTS	O	COM : TXD	O	OL	OL
57	P97	MRQ	O	COM : O-STROBE	O	OL	OL
58	PA0	/SBR	O	SUB CPU RESET	O	OL	OL
59	PA1	/FLR	O	FL RESET	O	OL	OL
60	PA2	T2I	O	TAPE2 MONITOR LED	O	OL	OL
61	PA3	/STBY	I/O	STANBY MODE	I/O	I	I
62	PA4	PSW	I	POWER SW DETECT	I	I	I
63	PA5	PSM	I	POWER SW MODE	I	I	I
64	PA6	/HPI	I	HEAD PHONE DETECT	I	I	I

IC17 : HD6473258P10
8 bit μ -COM (Sub CPU)

P6 ₀ /FTCI	1	○	64	P3 ₇ /A ₇
P6 ₁ /FTOA	2		63	P3 ₆ /A ₆
P6 ₂ /FTOB	3		62	P3 ₅ /A ₅
P6 ₃ /FTI	4		61	P3 ₄ /A ₄
P6 ₄ /IRQ ₀	5		60	P3 ₃ /A ₃
P6 ₅ /IRQ ₁	6		59	P3 ₂ /A ₂
P6 ₆ /IRQ ₂	7		58	P3 ₁ /A ₁
RES	8		57	P3 ₀ /A ₀
XTAL	9		56	P1 ₀ /A ₀
EXTAL	10		55	P1 ₁ /A ₁
MD ₁	11		54	P1 ₂ /A ₂
MD ₀	12		53	P1 ₃ /A ₃
NMI	13		52	P1 ₄ /A ₄
Vcc	14		51	P1 ₅ /A ₅
STBY	15		50	P1 ₆ /A ₆
Vss	16		49	P1 ₇ /A ₇
P4 ₀ /TMC ₀	17		48	Vss
P4 ₁ /TMC ₀	18		47	P2 ₀ /A ₈
P4 ₂ /TMR ₀	19		46	P2 ₁ /A ₉
P4 ₃ /TMC ₁	20		45	P2 ₂ /A ₁₀
P4 ₄ /TMRO ₁	21		44	P2 ₃ /A ₁₁
P4 ₅ /TMR ₁	22		43	P2 ₄ /A ₁₂
P4 ₆ /	23		42	P2 ₅ /A ₁₃
P4 ₇ /E	24		41	P2 ₆ /A ₁₄
P5 ₀ /TxDo	25		40	P2 ₇ /A ₁₅
P5 ₁ /RxDo	26		39	Vcc
P5 ₂ /SCK ₀	27		38	P7 ₇ /WAIT
P5 ₃ /TxD ₁	28		37	P7 ₆ /RD
P5 ₄ /RxD ₁	29		36	P7 ₅ /WR
P5 ₅ /SCK ₁	30		35	P7 ₄ /AS
P7 ₀ /IS	31		34	P7 ₃ /IOS
P7 ₁ /OS	32		33	P7 ₂ /BUSY

No.	PORT	NAME	I/O	FUNCTION
1	P60	/IC	O	CDSP / DIR IC
2	P61	KM1	O	DIR forcibly mode (L : ANALOG)
3	P62	CLD	O	DIR CE
4	P63	CCK	O	DIR CLK
5	P64//IRQ0	CD0	IRQ	DIR data / LOCK interrupt
6	P65//IRQ1	ERR	IRQ	DIR ERR detect interrupt
7	P66//IRQ2	/IRQ	IRQ	CDSP interrupt request
8	/RES	/RES		RESET
9	XTAL	XI		20MHz
10	EXTAL	XO		20MHz
11	MD1	MD1		+5V
12	MD0	MD0		+5V
13	/NMI	/NMI		+5V
14	VCC	VDD		+5V
15	/SYBY	/STBY		+5V
16	VSS	GND		GND
17	P40	DPD	O	A/D digital power down
18	P41	APD	O	A/D analog power down
19	P42	MUTO	I	DEMOD. MUTE OUT
20	P43	SSEL	O	SDSP / ZR select (H : SDSP)

IC17 : HD6473258P10
8 bit μ -COM (Sub CPU)

No.	PORT	NAME	I/O	FUNCTION
21	P44	/ZIC	O	ZR IC
22	P45	TXZ	O	SUB CPU→ZR serial data
23	ϕ	RXZ	I	ZR→SUB CPU serial data
24	P47/E	CLZ	O	ZR serial clock
25	P50/TXD0	TXD0	O	SDSP serial data
26	P51/RXD0	/CRS	O	SDSP strobe
27	P52/SCK0	SCK0	O	SDSPclock
28	P53/TXD1	TXD	O	SUB→MAIN CPU serial data (STM)
29	P54/RXD1	RXD	I	MAIN→SUB CPU serial data (MTS)
30	P55/SCK1	XCK	I	MAIN-SUB CPU I/F clock
31	P70	/IS	I	CPU I/F input strobe (MRQ)
32	P71	/OS	O	CPU I/F output strobe (SRQ)
33	P72	DAMT	O	DAC MUTE (H : MUTE)
34	/IOS	DEM1	O	DAC fs0 00, 01, 10, 11
35	/AS	DEM0	O	DAC fs1 44.1k, OFF, 48k, 32k
36	/WR	FS0	O	SDSP fs0
37	/RD	FS1	O	SDSP fs1
38	/WAIT			Not used
39	VCC	VDD		+5V
40	A15	INH	O	REC SEL.
41	A14	R1	O	REC SEL.
42	A13	R0	O	REC SEL.
43	A12	I2	O	INPUT SEL.
44	A11	I1	O	INPUT SEL.
45	A10	I0	O	INPUT SEL.
46	A9	OPT	I	CD COAX / OPT detect (H : COAX)
47	A8	/MUI	O	CDSP INPUT MUTE
48	VSS	GND		GND
49	A7	/WT	I	CDSP BUSY
50	A6	/MOE	O	CDSP OE (Output enable)
51	A5	/MWE	O	CDSP WE (Write enable)
52	A4	/MCE	O	CDSP CE (Chip enable)
53	A3	MA3	O	CDSP address
54	A2	MA2	O	
55	A1	MA1	O	
56	A0	MA0	O	
57	D0	MD0	I/O	CDSP data bus
58	D1	MD1	I/O	
59	D2	MD2	I/O	
60	D3	MD3	I/O	
61	D4	MD4	I/O	
62	D5	MD5	I/O	
63	D6	MD6	I/O	
64	D7	MD7	I/O	

DSP-A3090

IC BLOCKS

IC13 : ZR38500
AC-3 Decoder

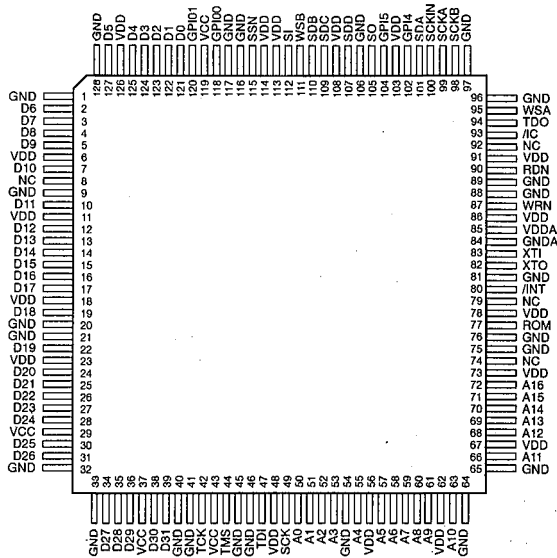

IC12 : TC55329AJ-35
32,768-word x 9 bit Static RAM

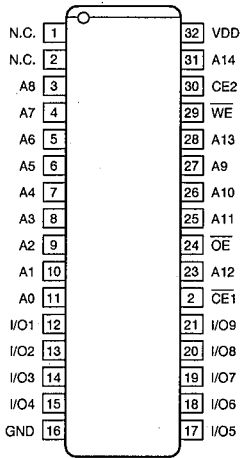

IC14~16, 43 : TC55328BJ-15
32,768-word x 8 bit Static RAM

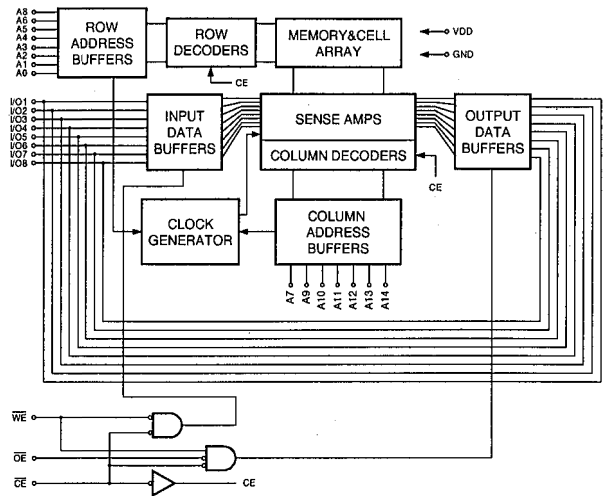
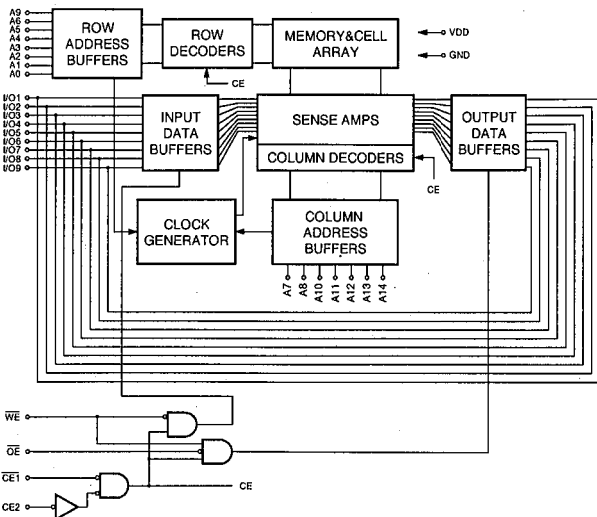
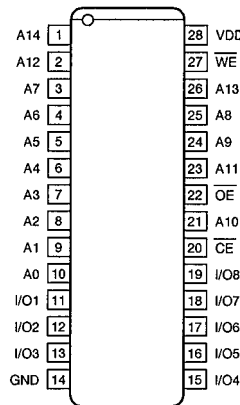

IC19, 20 : KM658128ALG-8
128k x 8 bit Pseudo Static RAM

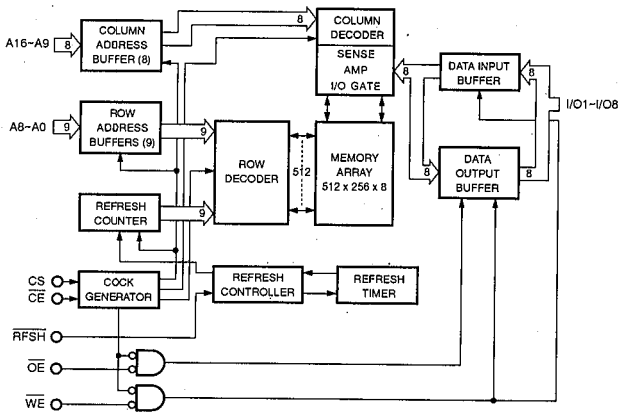
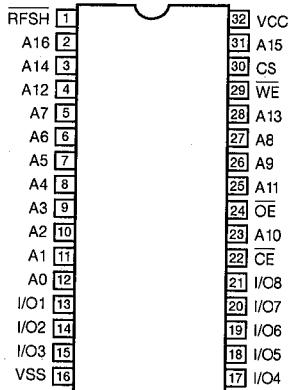

IC44 : MSM27C131ZB
131,072-word x 8 bit One Time PROM

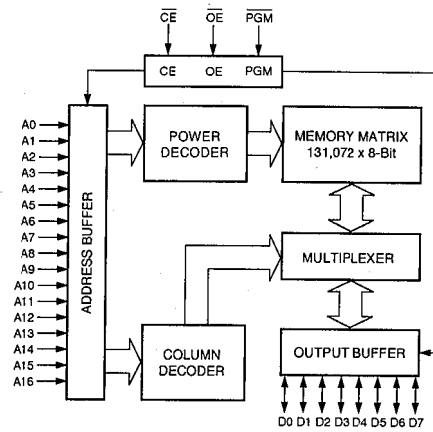
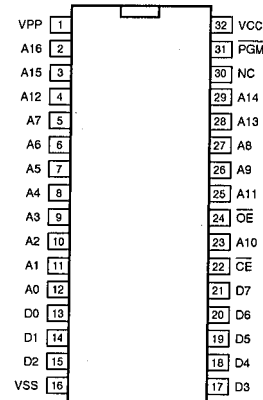

IC24 : AK5390-VS
20 bit 2-Channel A/D Converter

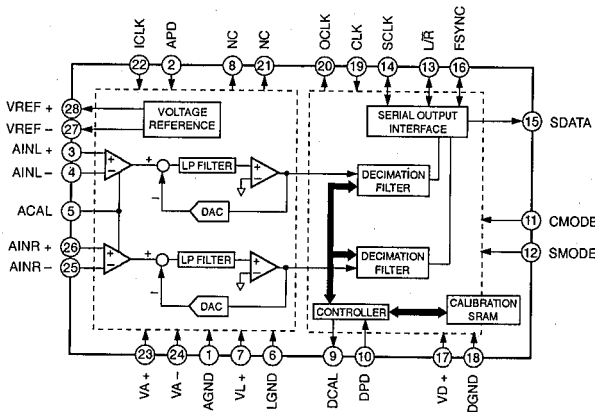

IC25~28 : AK4320-VM
1 bit D/A Converter

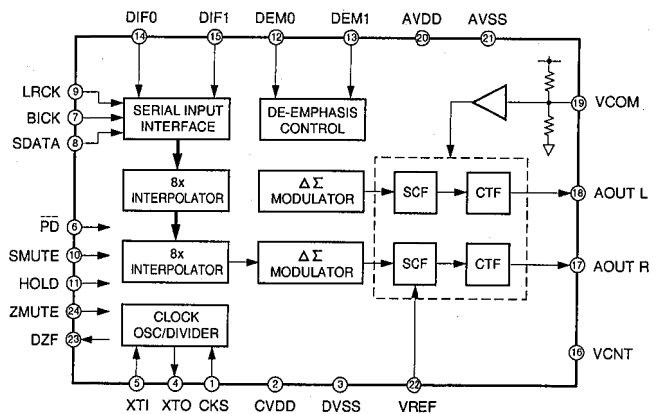

DSP-A3090

IC7 : TC74HC151AF
8 to 1 Data Selector

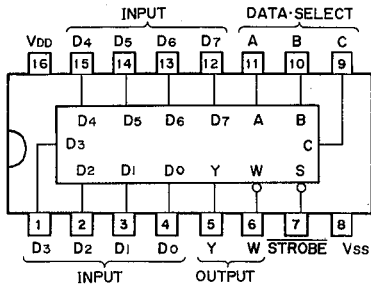

INPUT			OUTPUT		
SELECT			STROBE S	Y	W
C	B	A			
X	X	X	H	L	H
L	L	L	L	D ₀	$\overline{D_0}$
L	L	H	L	D ₁	$\overline{D_1}$
L	H	L	L	D ₂	$\overline{D_2}$
L	H	H	L	D ₃	$\overline{D_3}$
H	L	L	L	D ₄	$\overline{D_4}$
H	L	H	L	D ₅	$\overline{D_5}$
H	H	L	L	D ₆	$\overline{D_6}$
H	H	H	L	D ₇	$\overline{D_7}$

H: HIGH LEVEL L: LOW LEVEL X: H or L

IC4~7, 402, 403 : μ PD4051BC
Analog Multiplexers/Demultiplexers

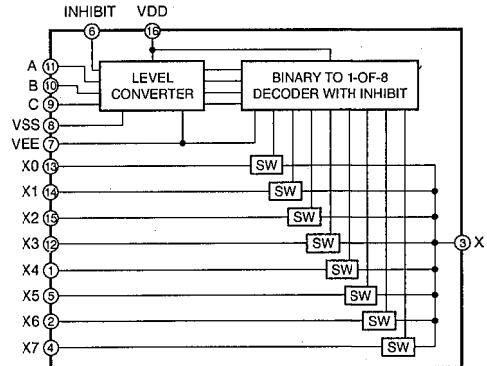

INPUT STATES				"ON" CHANNEL (S)
INHIBIT	C	B	A	
0	0	0	0	0
0	0	0	1	1
0	0	1	0	2
0	0	1	1	3
0	1	0	0	4
0	1	0	1	5
0	1	1	0	6
0	1	1	1	7
1	X	X	X	NONE

DSP-A3090

IC8, 42 : TC74HC153AF
Dual 4 to 1 Data Selector

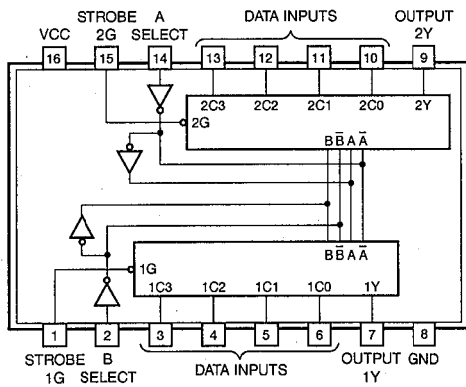

INPUTS		OUTPUT
SELECT	STROBE	Y
B A	G	Y
X X	H	L
L L	L	C0
L H	L	C1
H L	L	C2
H H	L	C3

IC9~11, 404 : μ PD4053BC
Triple 2-Channel Multiplexer/Demultiplexer

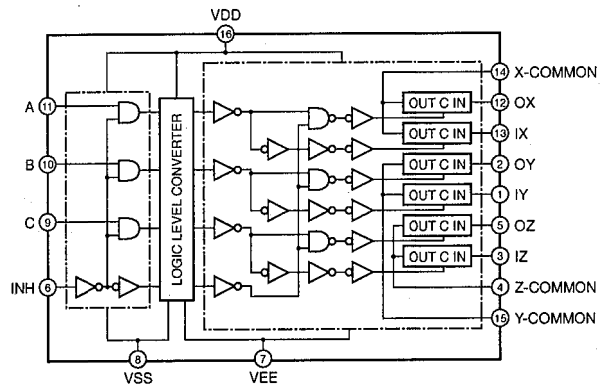

CONTROL INPUTS				"ON" CHANNEL		
INHIBIT (Pin 6)	C (Pin 9)	B (Pin 10)	A (Pin 11)	OX (Pin 12), OY (Pin 2), OZ (Pin 5) 1X (Pin 13), 1Y (Pin 1), 1Z (Pin 3)	2Y (Pin 2)	3Y (Pin 3)
L	L	L	L	OX, OY, OZ		
L	L	L	H	1X, OY, OZ		
L	L	H	L	OX, 1Y, OZ		
L	L	H	H	1X, 1Y, OZ		
L	H	L	L	OX, OY, 1Z		
L	H	L	H	1X, OY, 1Z		
L	H	H	L	OX, 1Y, 1Z		
L	H	H	H	1X, 1Y, 1Z		
H	*	*	*	NOTE		

* Don't Care

IC19, 404 : TC9162AN
Analog Function Switch

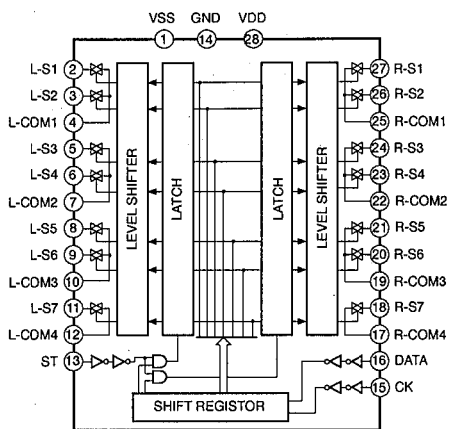

IC8 : LC7824
Analog Function Switch

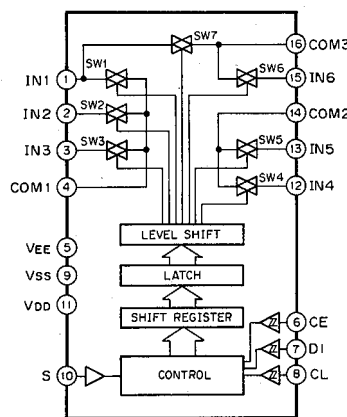

IC20 : LC78213
Analog Function Switch

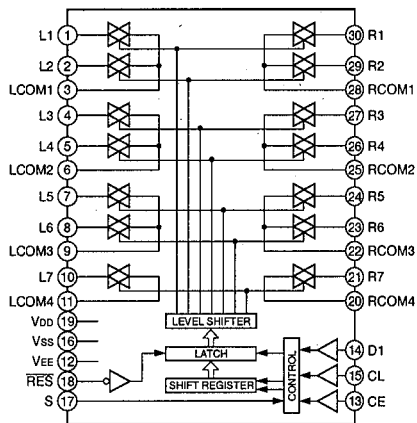

IC403, 405 : TC9273N-004
Analog Function Switch

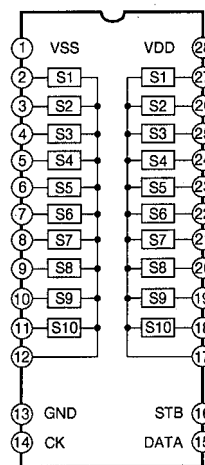

IC16~18 : LC7536
Electric Controlled Volume

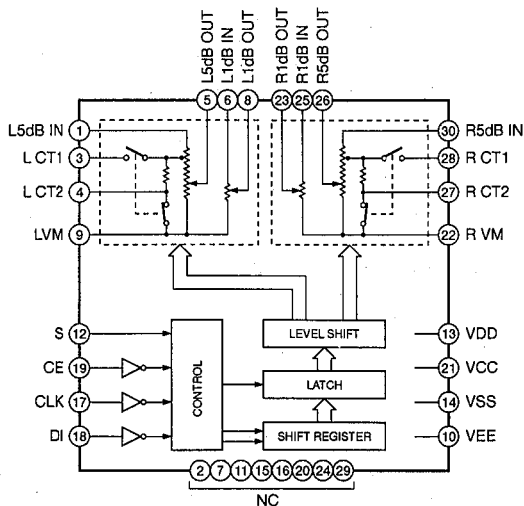

IC301, 302 : LB1641
Motor Driver

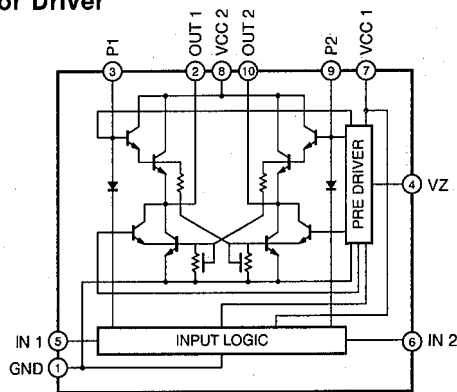

DSP-A3090

IC901, 902 : LC75710NE
FL Display Driver

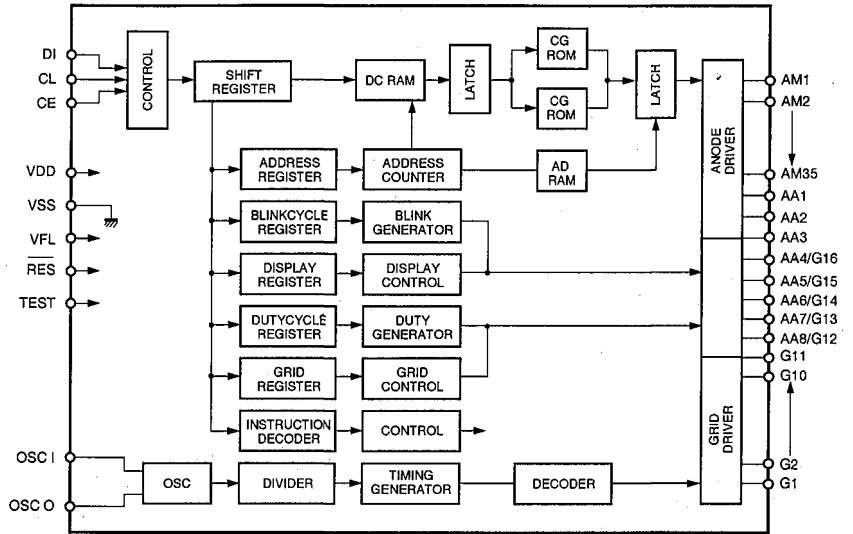
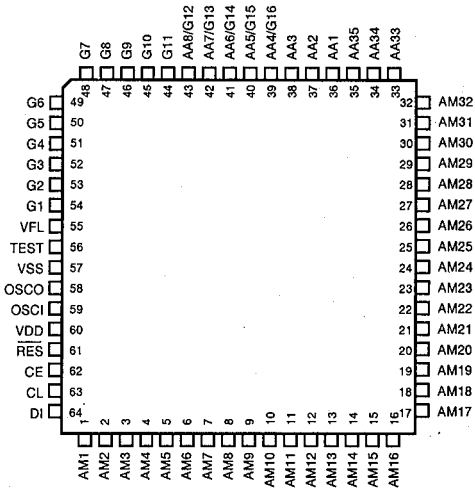

DSP-A3090

IC301, 302 : μ PC1225H
Power Amp

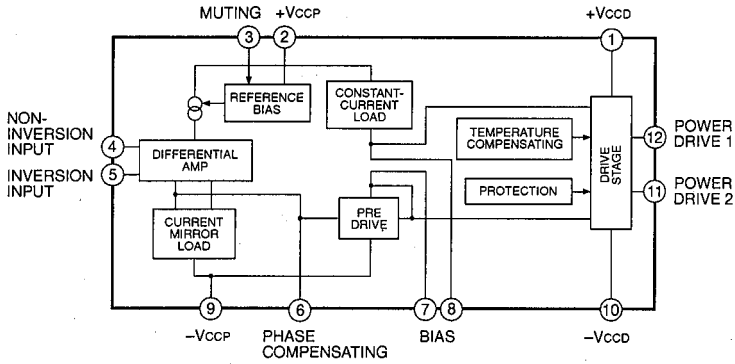

IC6, 23 : μ PD74HC00G
Quad 2 Input NAND

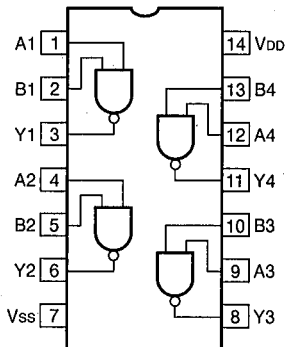

IC9, 10 : TC74HCU04AF
IC13, 14 : TC74HCU04AP
IC22 : μ PD74HC04G
Hex Inverters

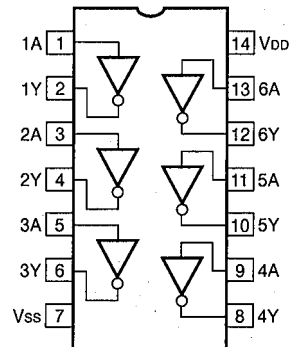

IC1~3, 401 : MC14576CP
Dual Video Amp

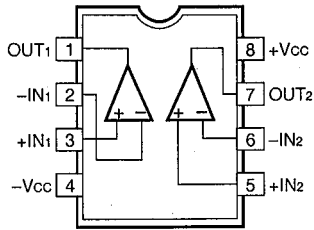

IC2 : LT1016IN8

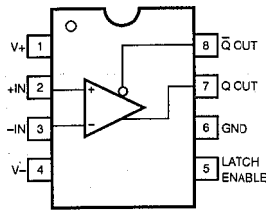

IC802 : μ PC4570HA
Dual OP-Amp

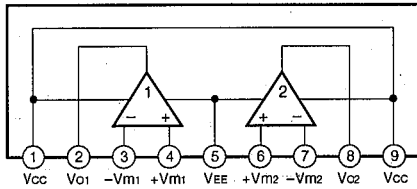

IC1 : MC14577CP (DSP)
IC3, 37~40 : μ PC4570G2 (DSP)
IC4, 5 : NJM2904G (DSP)
IC3, 4, 9~12, 15, 21~23 : μ PC4570G2 (FUNCTION)
IC5~8 : NJM2068MD (FUNCTION)
Dual OP-Amp

IC401, 402, 801, 803 : NJM2068L
IC804 : NJM4556AL
Dual OP-Amp

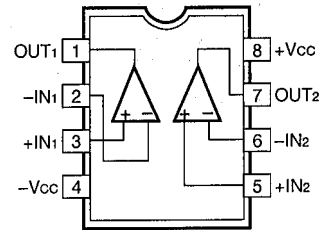
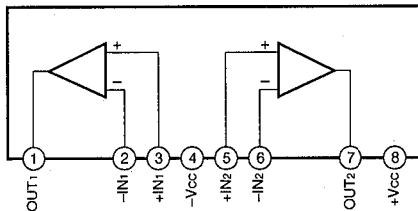

IC13, 14, 24, 25, 501, 502 : μ PC4574G2 (FUNCTION)
IC31 : μ PC4574G2 (DSP)
4-Channel OP-Amp

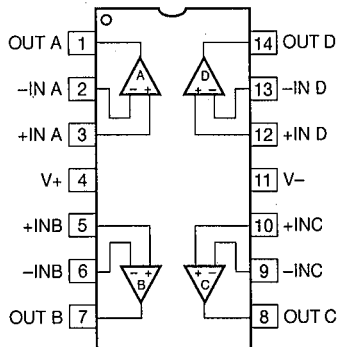

- Other ICs
- IC11 : PD4606A → See page 23
 - IC21 : YM3436DK → See page 26
 - IC41 : YSS213 → See page 27
 - IC18 : YSS214 → See page 29
 - IC1 : HD6473614P → See page 33
 - IC17 : HD6473258P10 → See page 35
 - IC12 : M35010-062SP → See page 32

■ DISPLAY DATA (VT876400)

V901 : 32-BT-02G

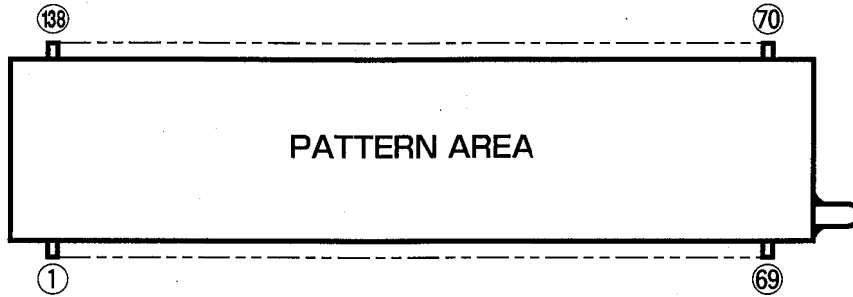

GRID ASSIGNMENT

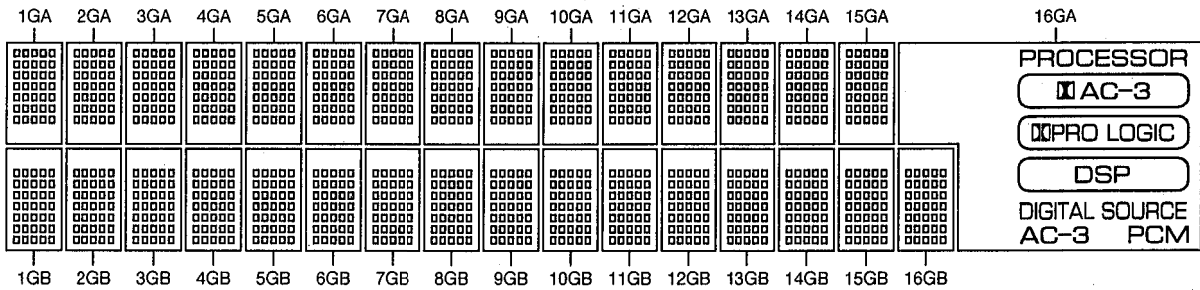

DSP-A3090

SEGMENT DESIGNATION

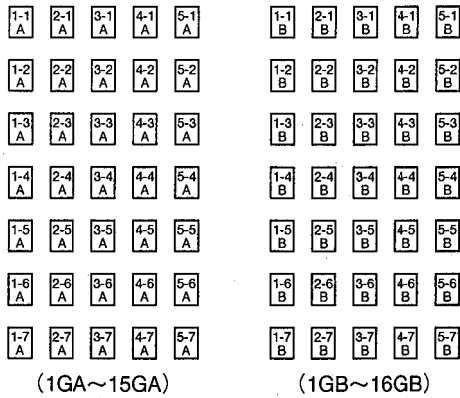

PIN CONNECTION

Pin No.	Connection	Pin No.	Connection	Pin No.	Connection	Pin No.	Connection	Pin No.	Connection	Pin No.	Connection	Pin No.	Connection
1	F1	21	P20B	41	NC	61	P4B	81	P19A	101	P27A	121	13GA
2	F1	22	P19B	42	NC	62	P3B	82	P18A	102	P28A	122	12GA
3	F1	23	P18B	43	NC	63	P2B	83	P17A	103	P29A	123	11GA
4	NP	24	P17B	44	NC	64	P1B	84	P16A	104	P30A	124	10GA
5	NP	25	P16B	45	1GB	65	NP	85	P15A	105	P31A	125	9GA
6	P26B	26	IC	46	2GB	66	NP	86	P14A	106	P32A	126	8GA
7	P27B	27	16GB	47	3GB	67	F2	87	P13A	107	P33A	127	7GA
8	P28B	28	15GB	48	4GB	68	F2	88	P12A	108	P34A	128	6GA
9	P29B	29	14GB	49	5GB	69	F2	89	P11A	109	P35A	129	5GA
10	P30B	30	13GB	50	P15B	70	F2	90	P10A	110	NC	130	4GA
11	P31B	31	12GB	51	P14B	71	F2	91	P9A	111	IC	131	3GA
12	P32B	32	11GB	52	P13B	72	F2	92	P8A	112	NC	132	2GA
13	P33B	33	10GB	53	P12B	73	NP	93	P7A	113	NC	133	1GA
14	P34B	34	9GB	54	P11B	74	NP	94	P6A	114	NC	134	NP
15	P35B	35	8GB	55	P10B	75	P25A	95	P5A	115	NC	135	NP
16	P25B	36	7GB	56	P9B	76	P24A	96	P4A	116	NC	136	F1
17	P24B	37	6GB	57	P8B	77	P23A	97	P3A	117	NC	137	F1
18	P23B	38	NC	58	P7B	78	P22A	98	P2A	118	16GA	138	F1
19	P22B	39	NC	59	P6B	79	P21A	99	P1A	119	15GA		
20	P21B	40	NC	60	P5B	80	P20A	100	P26A	120	14GA		

Note : F1, F2 : Filament NP : No Pin NC : No Connection DL : Datum Line 1GA~16GA, 1GB~16GB : Grid
IC : Internal Connection

ANODE CONNECTION

	1GA~15GA	16GA		1GA~15GA	16GA		1GA~15GA	16GA		1GA~15GA	16GA
P1A	1-1A	—	P11A	1-3A	—	P21A	1-5A	—	P31A	1-7A	PRO LOGIC
P2A	2-1A	—	P12A	2-3A	—	P22A	2-5A	—	P32A	2-7A	DSP
P3A	3-1A	—	P13A	3-3A	—	P23A	3-5A	—	P33A	3-7A	DIGITAL SOURCE
P4A	4-1A	—	P14A	4-3A	—	P24A	4-5A	—	P34A	4-7A	AC-3
P5A	5-1A	—	P15A	5-3A	—	P25A	5-5A	—	P35A	5-7A	PCM
P6A	1-2A	—	P16A	1-4A	—	P26A	1-6A	—			
P7A	2-2A	—	P17A	2-4A	—	P27A	2-6A	—			
P8A	3-2A	—	P18A	3-4A	—	P28A	3-6A	—			
P9A	4-2A	—	P19A	4-4A	—	P29A	4-6A	PROCESSOR			
P10A	5-2A	—	P20A	5-4A	—	P30A	5-6A	AC-3			

	1GB~16GB		1GB~16GB		1GB~16GB		1GB~16GB
P1B	1-1B	P11B	1-3B	P21B	1-5B	P31B	1-7B
P2B	2-1B	P12B	2-3B	P22B	2-5B	P32B	2-7B
P3B	3-1B	P13B	3-3B	P23B	3-5B	P33B	3-7B
P4B	4-1B	P14B	4-3B	P24B	4-5B	P34B	4-7B
P5B	5-1B	P15B	5-3B	P25B	5-5B	P35B	5-7B
P6B	1-2B	P16B	1-4B	P26B	1-6B		
P7B	2-2B	P17B	2-4B	P27B	2-6B		
P8B	3-2B	P18B	3-4B	P28B	3-6B		
P9B	4-2B	P19B	4-4B	P29B	4-6B		
P10B	5-2B	P20B	5-4B	P30B	5-6B		

DSP-A3090

PIN CONNECTION DIAGRAM

● ICs

<p>NJM78L05A</p>	<p>AN78N05</p>	<p>AN79N05</p>	<p>NJM78M15FA</p>	<p>NJM79M05FA NJM79M15FA</p>	<p>PQ05RF1</p>	<p>NJM2068L NJM4556AL</p>
<p>μPC4570HA</p>	<p>LB1641</p>	<p>μPC1225H</p>	<p>LT1016IN8 MC14576CP MC14577CP NJM2068MD</p>	<p>TC74HCU04AP</p>	<p>LC7824 μPD4051BC μPD4053BC</p>	<p>M35010-062SP</p>
<p>TC9162AN TC9273N-004</p>	<p>TC55328BJ-15</p>	<p>LC7536 LC78213</p>	<p>TC55329AJ-35</p>	<p>HD6473256P HD6473614P YSS213</p>		
<p>NJM2904G μPC4570G</p>	<p>TC74HCU04AF μPC4574G2 μPD74HC00G μPD74HC04G</p>	<p>TC74HC151AF TC74HC153AF</p>	<p>AK4320-VS</p>	<p>AK5390-VS</p>	<p>KM658128ALG-8 MSM27C131ZB</p>	
<p>YM3446DK</p>	<p>LC75710NE</p>	<p>PD4606A</p>	<p>YSS214</p>	<p>ZR38500</p>		

● Diodes

<p>1SS133 1SR139-100 AK04</p>	<p>MTZJ2.0B MTZJ4.3A MTZJ5.1A MTZJ5.1B MTZJ6.8A MTZJ9.1C MTZJ13.0A MTZJ15.0B MTZJ33.0D</p>	<p>D3SBA20 RBA-406B RBV-602</p>
<p>ISS355</p>	<p>KV1851-TL</p>	<p>S1NB20</p>

● Transistors

<p>2SA933S (Q, R) 2SC1740S (R, S) 2SC2603 (E, F) 2SD1915F (S, T) DTA143ES DTC114ES DTC143XS DTC144ES</p>	<p>2SA1708(S,T)</p>	<p>2SC1846(S)</p>	<p>2SA1940 (R,O) 2SC5197 (R,O)</p>
<p>2SA970 (GR, BL) 2SA1015 (Y) 2SA1145 (O, Y) 2SC535 (A, B, C) 2SC1815 (Y) 2SC2240 (GR, BL) 2SC2705 (O, Y) 2SC2878 (A, B)</p>	<p>2SC2412K(Q,R,S) 2SC3326(A,B) DTA144EK</p>	<p>2SA1837 2SC4793 2SD2396(J,K)</p>	<p>2SA1302(O,R) 2SC3281(O, R)</p>

PRINTED CIRCUIT BOARD (Foil side)

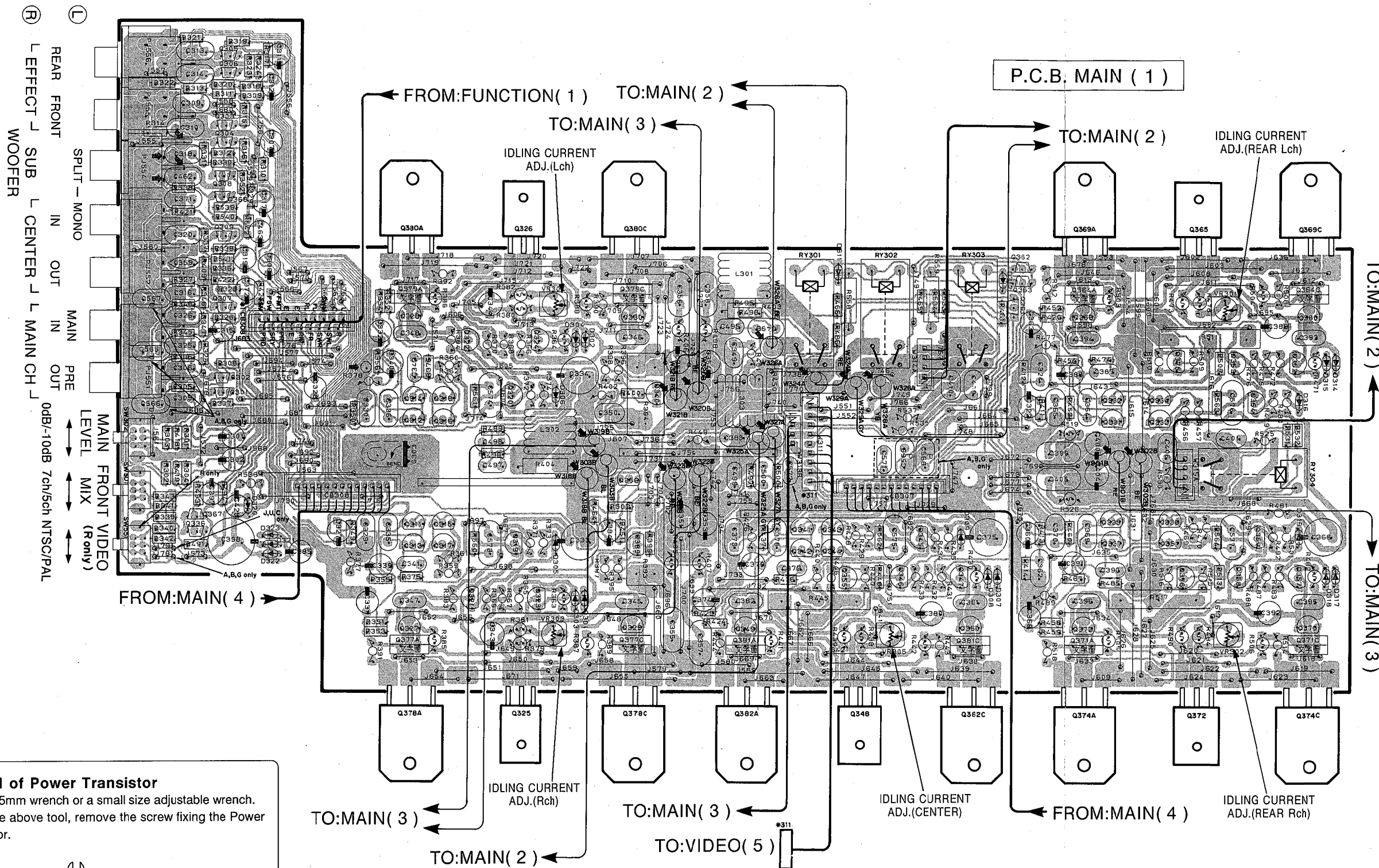

Removal of Power Transistor

- a. Use a 5.5mm wrench or a small size adjustable wrench.
- b. Using the above tool, remove the screw fixing the Power Transistor.

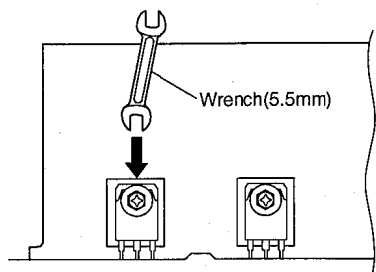

Semiconductor Location

Ref. No.	Location	Ref. No.	Location	Ref. No.	Location	Ref. No.	Location	Ref. No.	Location	Ref. No.	Location	Ref. No.	Location	Ref. No.	Location
Q 301	B3	Q 313	C4	Q 324	D3	Q 335	F2	Q 346	E4	Q 357	G4	Q 367	B3	Q 375	G3
Q 302	B3	Q 314	C3	Q 325	D4	Q 336	B3	Q 347	F4	Q 358	G4	Q 368	B2	Q 376	G4
Q 303	B2	Q 315	C3	Q 326	D2	Q 337	F4	Q 348	E4	Q 359	G4	Q 369A	F2	Q 377A	C4
Q 304	B2	Q 316	C3	Q 327	C4	Q 338	G3	Q 349	E4	Q 360	G3	Q 369C	G2	Q 377C	D4
Q 305	B1	Q 317	C4	Q 328	C2	Q 339	D4	Q 350	F4	Q 361	F2	Q 370	G4	Q 378A	C4
Q 306	B1	Q 318	C3	Q 329	D4	Q 340	D3	Q 351	G4	Q 362	F2	Q 371A	F4	Q 378C	D4
Q 307	B2	Q 319	D4	Q 330	D2	Q 341	E3	Q 352	G3	Q 363	F2	Q 371C	G4	Q 379A	C2
Q 308	B2	Q 320	D3	Q 331	F3	Q 342	E4	Q 353	G3	Q364A	F2	Q 372	G4	Q 379C	D2
Q 309	B2	Q 321	C4	Q 332	F3	Q 343	E3	Q 354	G3	Q364C	G2	Q 373	F4	Q 380A	C2
Q 311	C3	Q 322	C3	Q 333	G3	Q 344	E4	Q 355	E4	Q 365	G2	Q 374A	F4	Q 380C	B2
Q 312	C3	Q 323	D4	Q 334	G3	Q 345	E4	Q 356	D3	Q 366	F2	Q 374C	G4	Q 381A	E4

Q381C	F4
Q382A	E4
Q382C	F4

PRINTED CIRCUIT BOARD (Foil side)

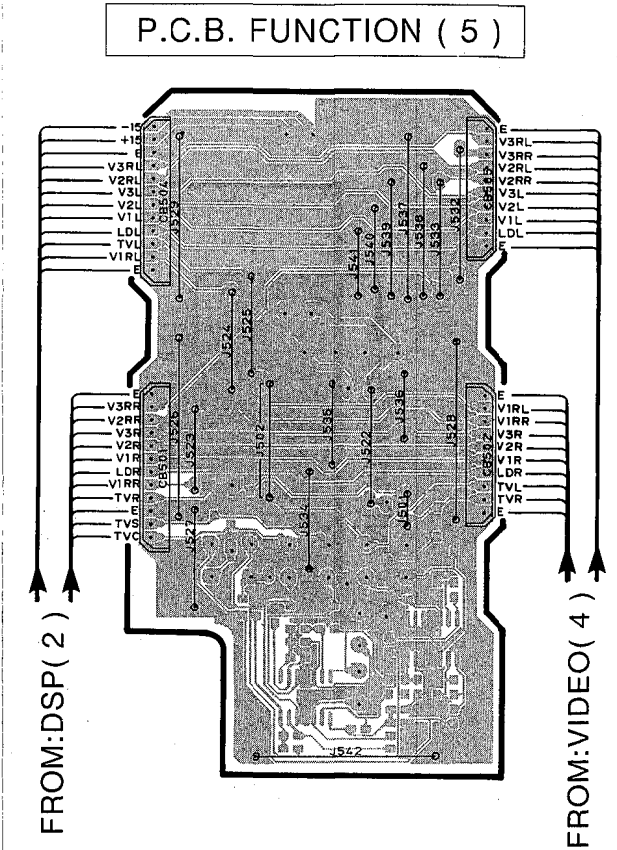
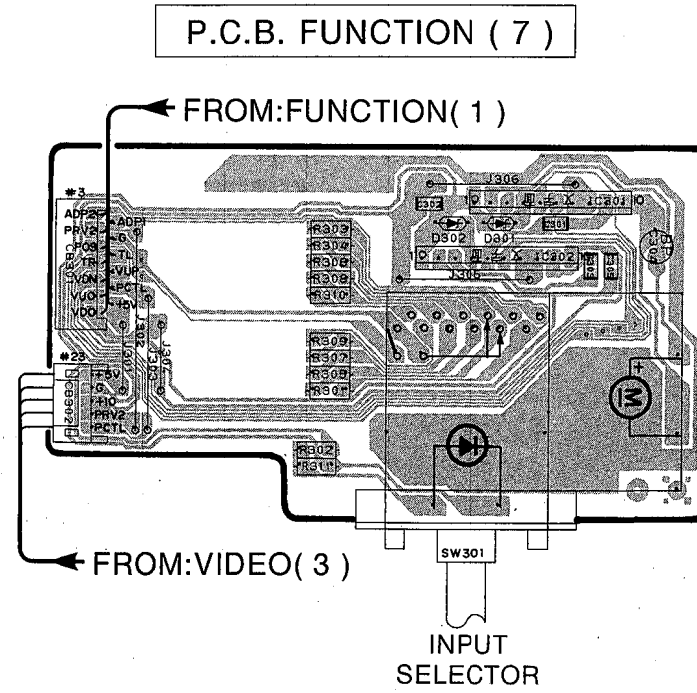
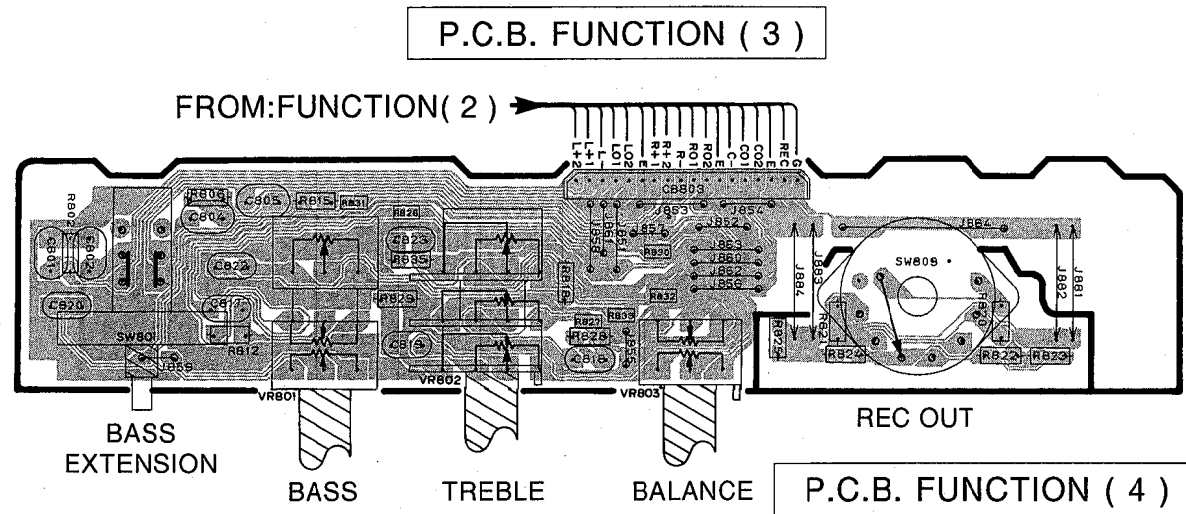

Semiconductor Location

Ref. No.	Location	Ref. No.	Location
IC301	E2	Q801	E4
IC302	E2	Q802	E4
IC801	F4	Q803	E4
IC802	E4	Q804	E4
IC803	F4		
IC804	E4		

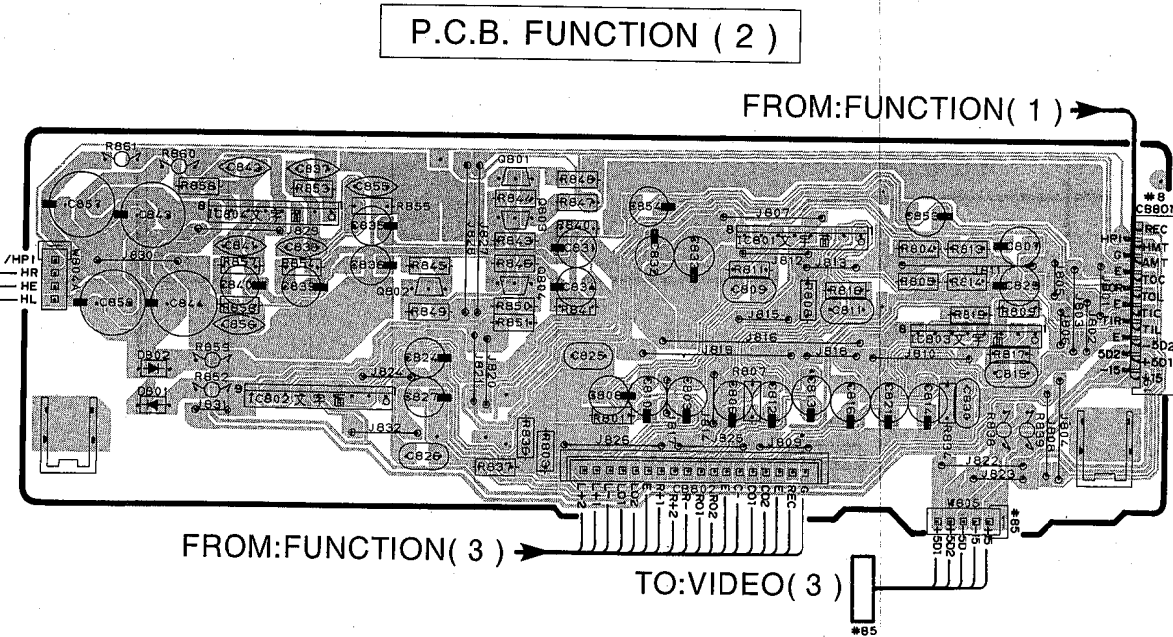
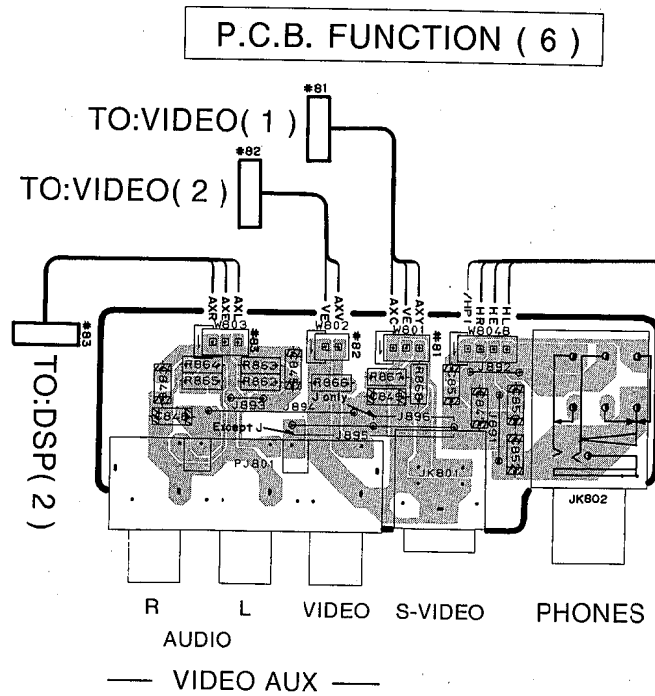

PRINTED CIRCUIT BOARD (Foil side)

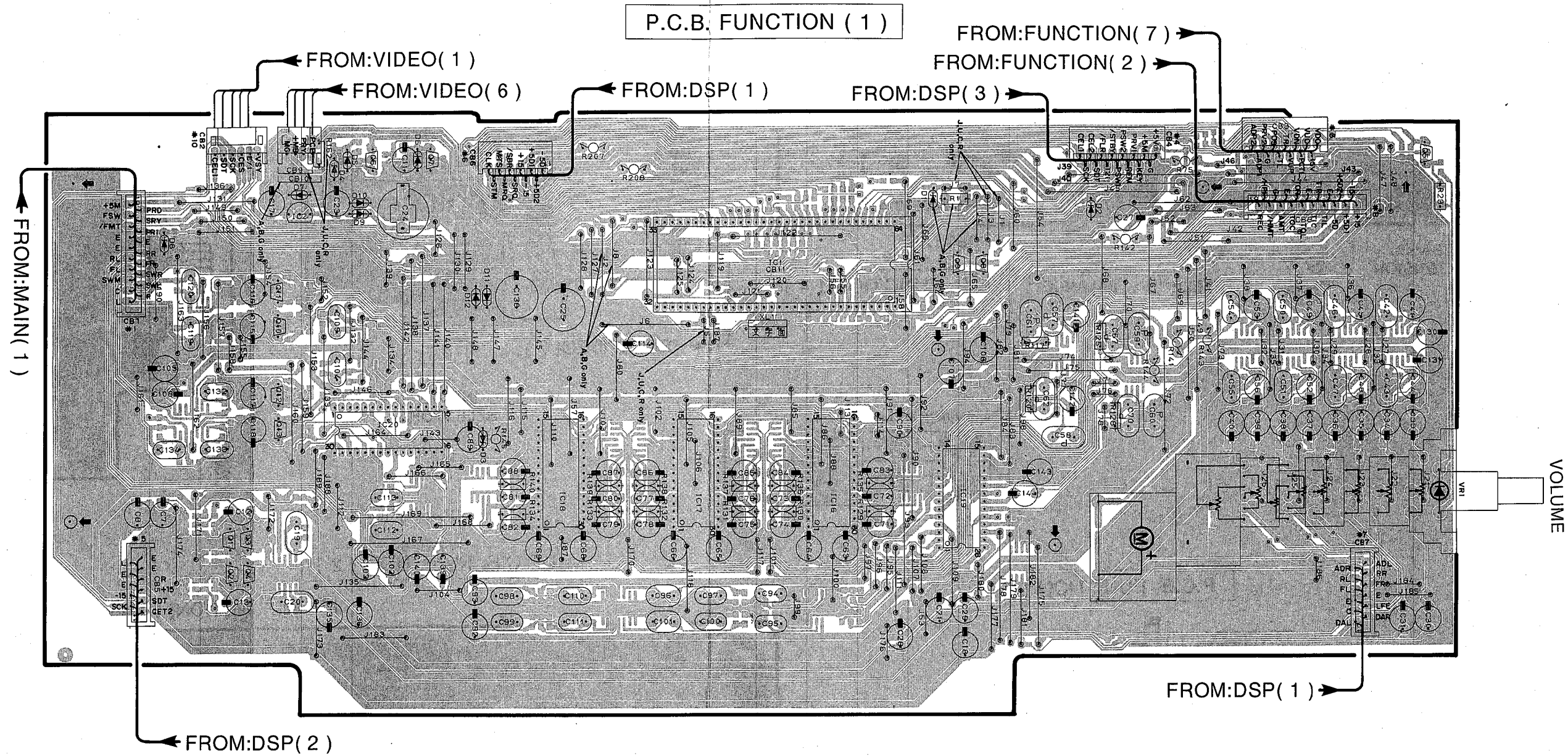

● Semiconductor Location

Ref. No.	Location	Ref. No.	Location
IC 1	E2	Q 1	B3
IC 2	C2	Q 2	B4
IC 16	E3	Q 3	B3
IC 17	D3	Q 4	B4
IC 18	D3	Q 5	G2
IC 19	E3	Q 6	C2
IC 20	C3	Q 7	C2
		Q 8	E2
		Q 9	E2
		Q 10	B2
		Q 11	B2
		Q 12	B3
		Q 13	B3

P.C.B. FUNCTION (1)

1
2
3
4
5
6

■ PRINTED CIRCUIT BOARD (Foil side)

① and ② : TEST POINT WAVEFORMS (See page 22)

P.C.B. FUNCTION (1)

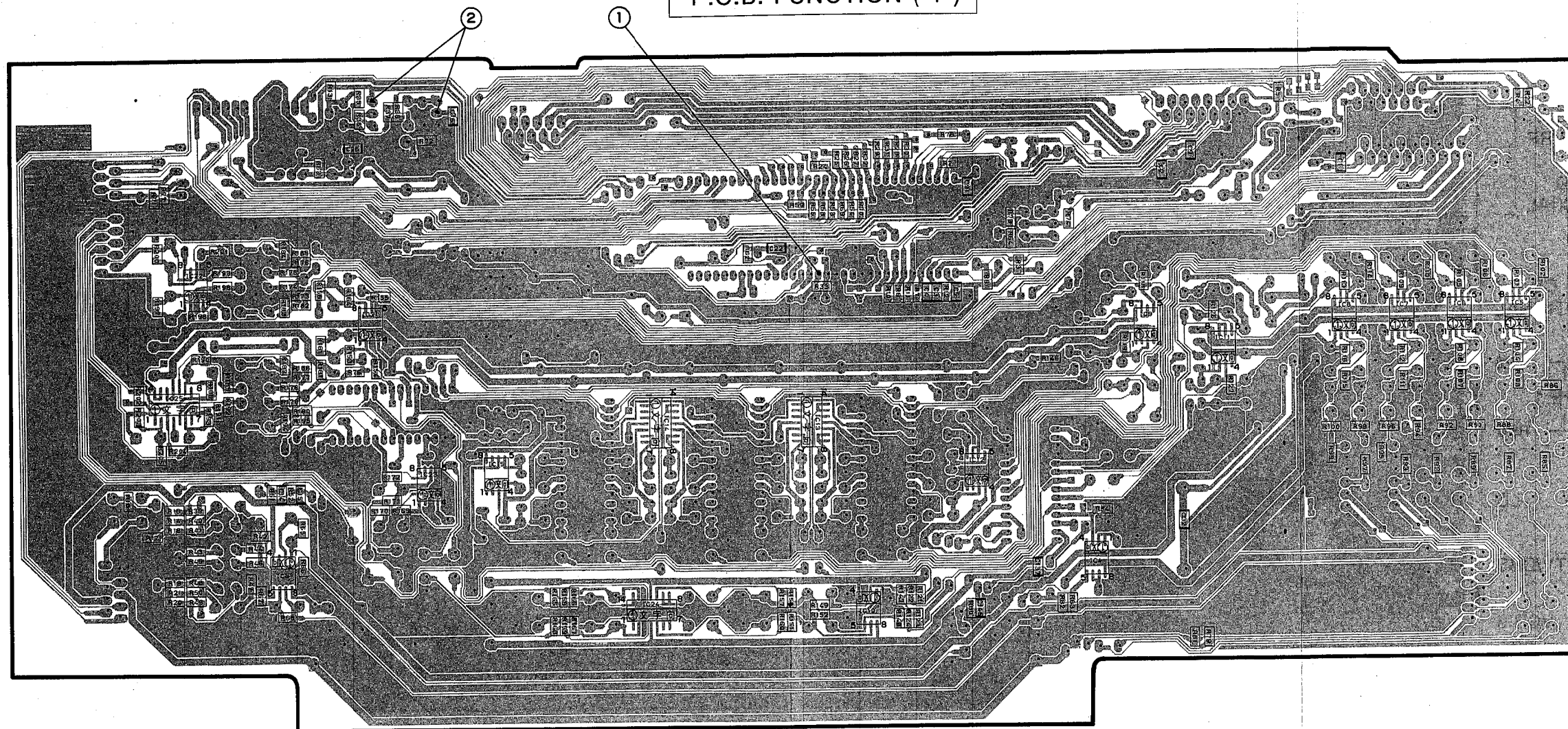

● Semiconductor Location

Ref. No.	Location	Ref. No.	Location
IC 3	B3	IC 21	C2
IC 4	E3	IC 22	B2
IC 5	G2	IC 23	C3
IC 6	G2	IC 24	D4
IC 7	G2	IC 25	B3
IC 8	F2		
IC 9	F2		
IC 10	E4		
IC 11	F3		
IC 12	E3		
IC 13	D2		
IC 14	D3		
IC 15	C3		

1

2

3

4

5

6

■ PRINTED CIRCUIT BOARD (Parts side)

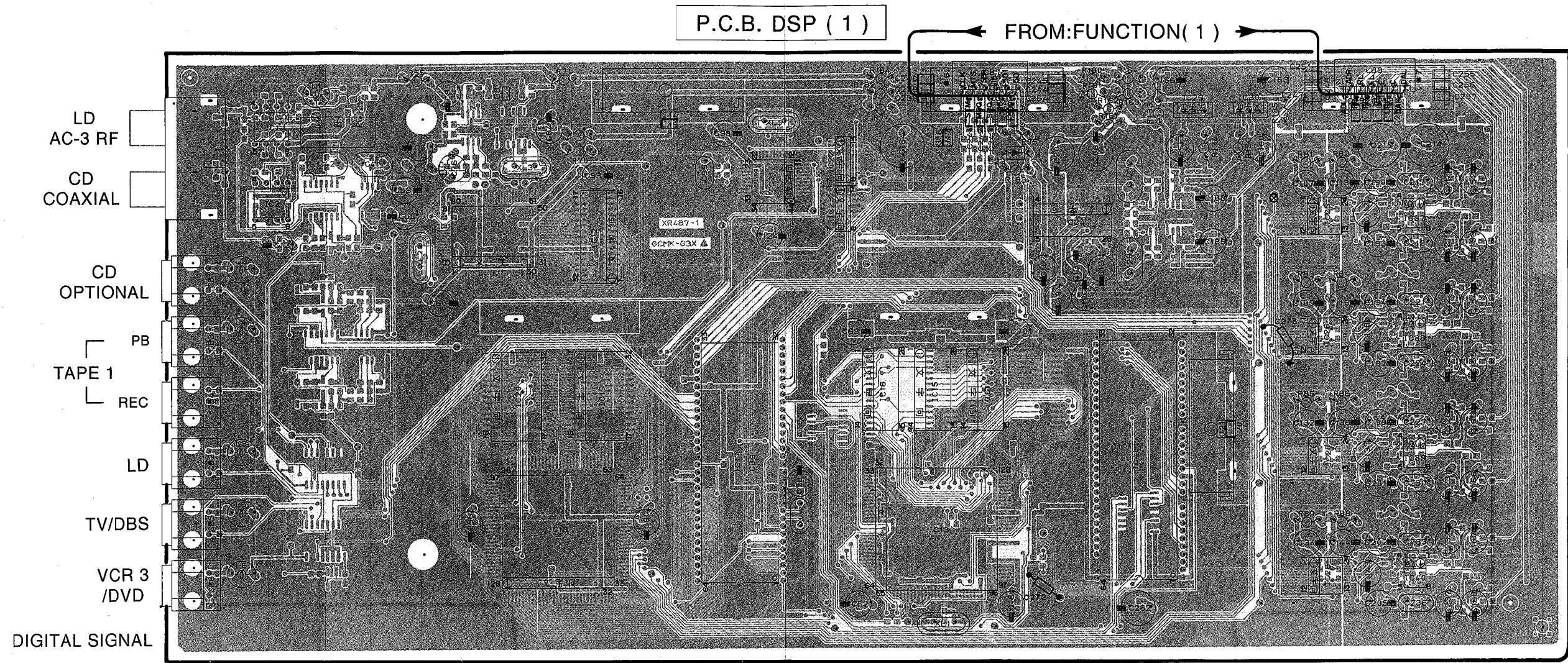

ZR38500(IC13) version and peripheral circuit parts

There are two versions (A2 version and A3 version) of AC-3 decoder ZR38500 (IC13). The A3 version is an upper version of the A2 version and requires less number of peripheral circuit parts. Therefore, be careful for what parts to use when repairing or replacing a faulty part. Use of a wrong part may result in an operation failure. Be sure to check with the table below as it shows the parts that should be used for each version.

ZR38500(IC13) version	ROM (IC44)	SRAM (IC14~16)	SRAM (IC43)	Jumper (J1)	Jumper (J2)	Resistor (R187)	Version displayed when DIAG 11 is used
A2	○	○15nsec	○15nsec	○	×	×	A2+ROM
A3 (used as A2)	○	○15nsec	○15nsec	○	×	×	A2+ROM
A3 (used as A3)	×	○15~35nsec	×	×	○	○47kΩ	A3

Note)

- "○" in the table means that part is used and "×" means that part is not used.
- Figures in SRAM columns indicate the access speed required.
- Since the A3 version is an upper compatible version of the A2 version, if A2 is loaded on A3 as it is, it can operate as the A2 version.

● Semiconductor Location

Ref. No.	Location	Ref. No.	Location
IC 1	B2	IC 23	E2
IC 2	B2	IC 24	F2
IC 11	C2	IC 25	G2
IC 12	D2	IC 26	G3
IC 13	E3	IC 27	G3
IC 14	E3	IC 28	G4
IC 15	E3	IC 29	F2
IC 16	E3	IC 30	F2
IC 17	D3	IC 37	G2
IC 18	C3	IC 38	G3
IC 19	D3	IC 39	G3
IC 20	C3	IC 40	G4
IC 21	D2	IC 41	F3
IC 22	E2		

■ PRINTED CIRCUIT BOARD (Foil side) ③ to ⑦ : TEST POINT WAVEFORMS (See page 22)

P.C.B. DSP (1)

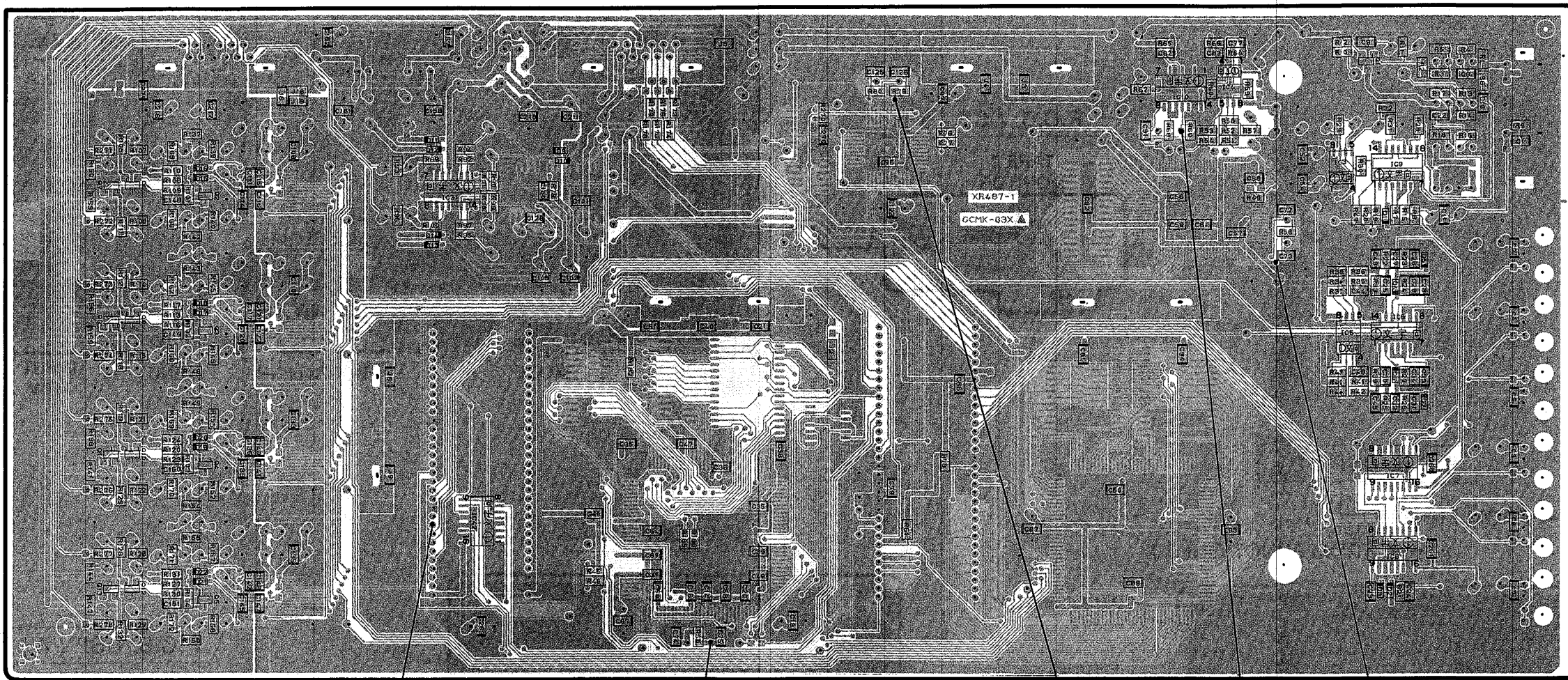

⑦

⑥

⑤

③

④

● Semiconductor Location

Ref. No.	Location	Ref. No.	Location
IC 3	F2	Q 1	G2
IC 4	F2	Q 2	B2
IC 5	F3	Q 3	B3
IC 6	G3	Q 4	B3
IC 7	G3	Q 5	B4
IC 8	G3	Q 6	B2
IC 9	G2	Q 7	B2
IC 10	F2	Q 8	B2
IC 31	C2	Q 9	B2
IC 42	C3	Q 10	B3
		Q 11	B3
		Q 12	B3
		Q 13	B3

■ PRINTED CIRCUIT BOARD (Foil side)

Note) When replacing the V901 FL display (VT876400), replace it together with the FL support (VU018900).

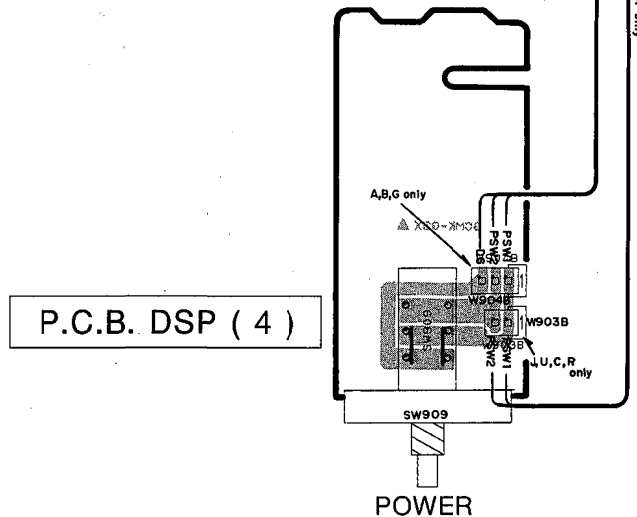
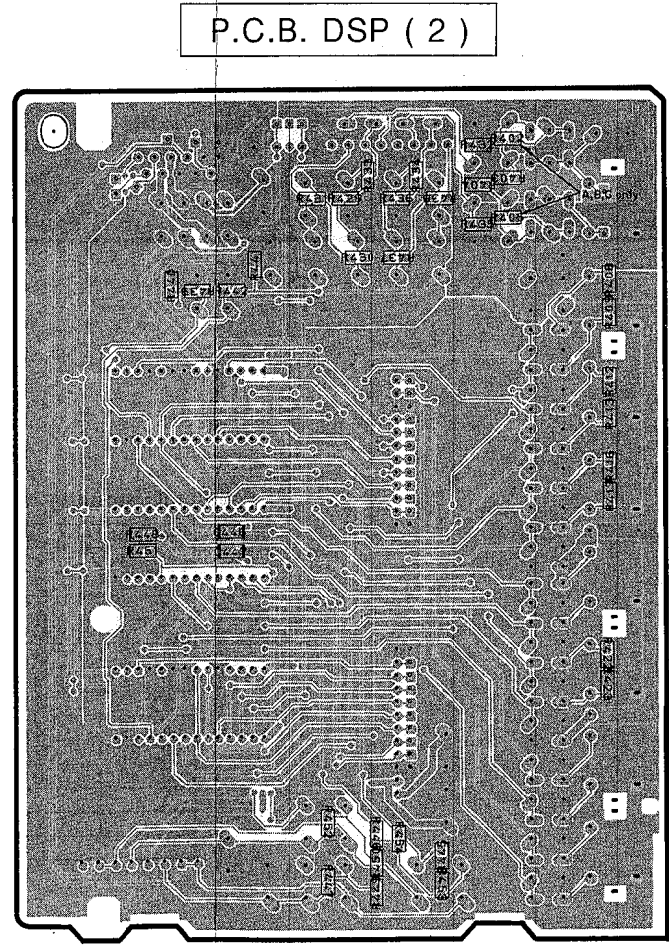
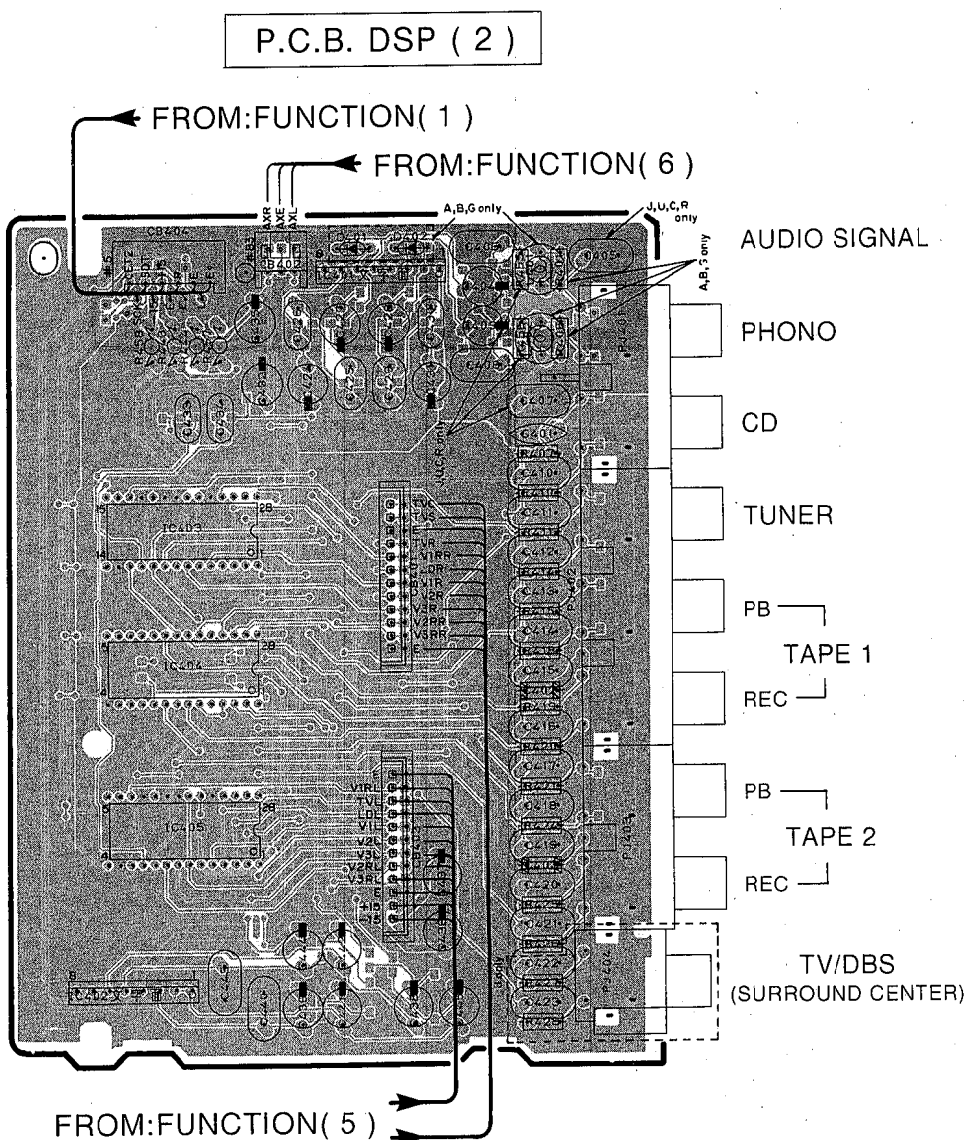
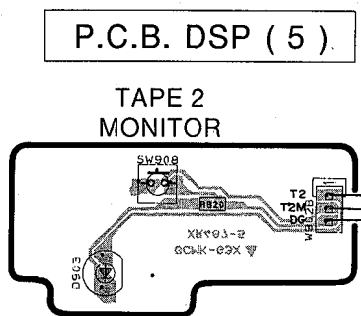
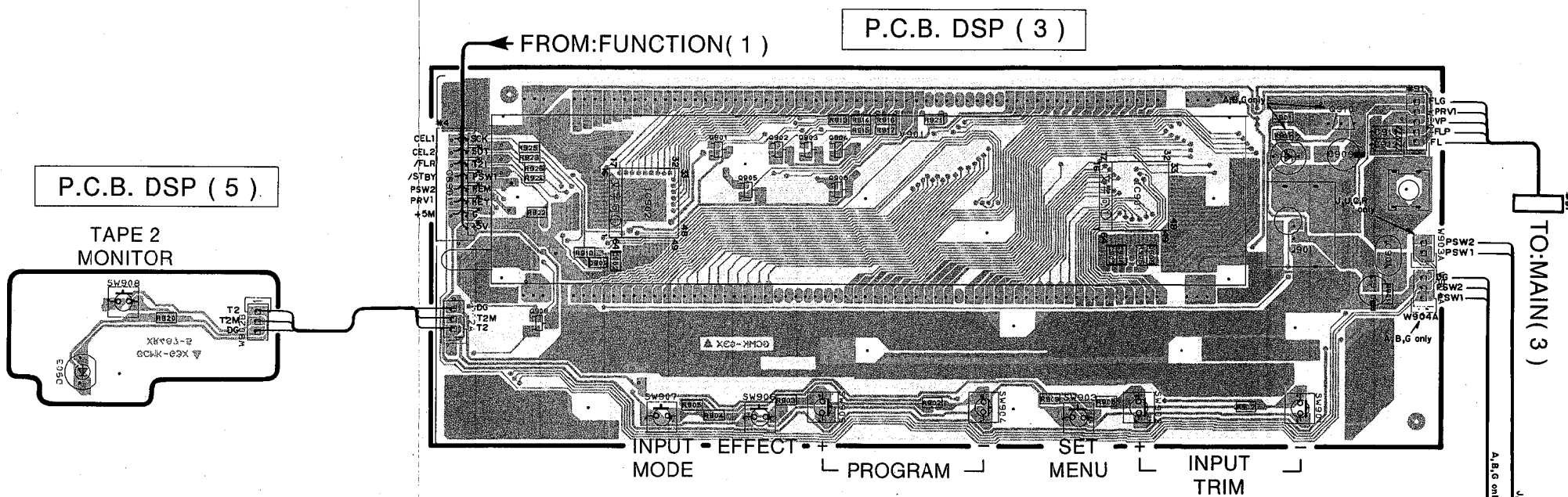

PRINTED CIRCUIT BOARD (Foil side) ⑧ : TEST POINT WAVEFORMS (See page 22)

1

2

3

4

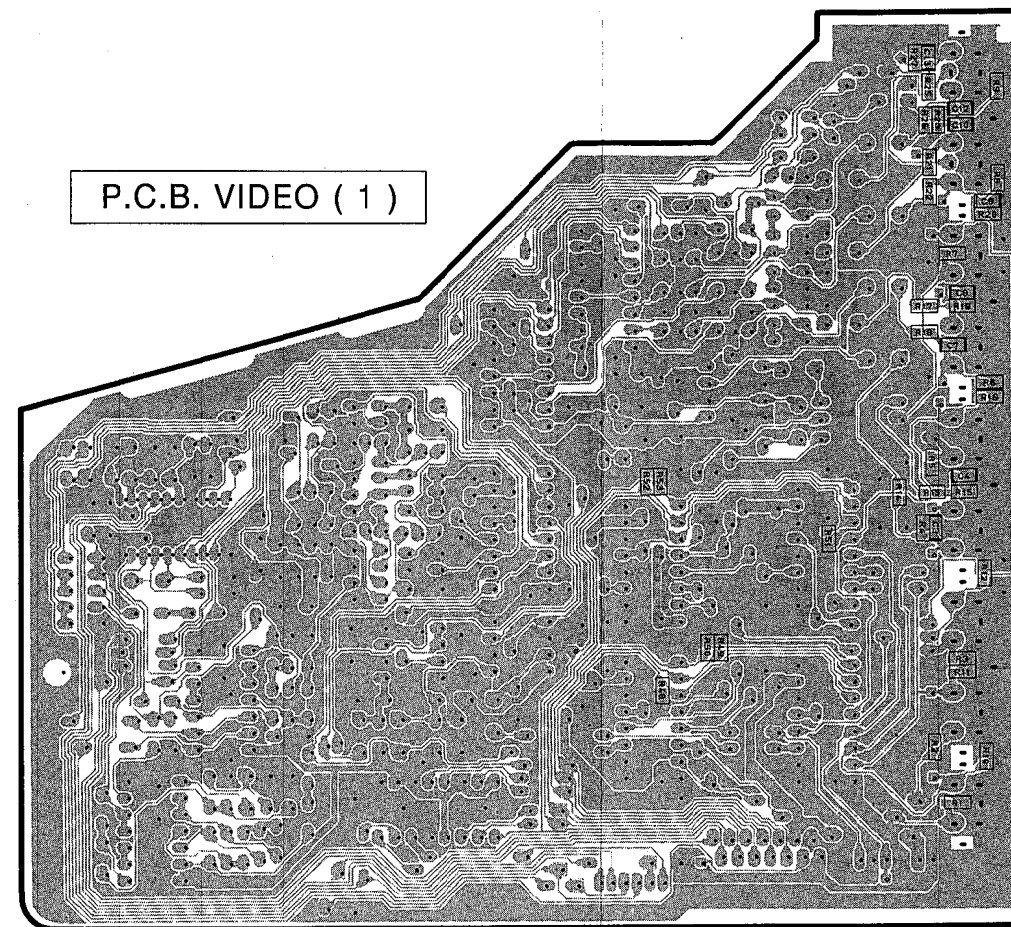
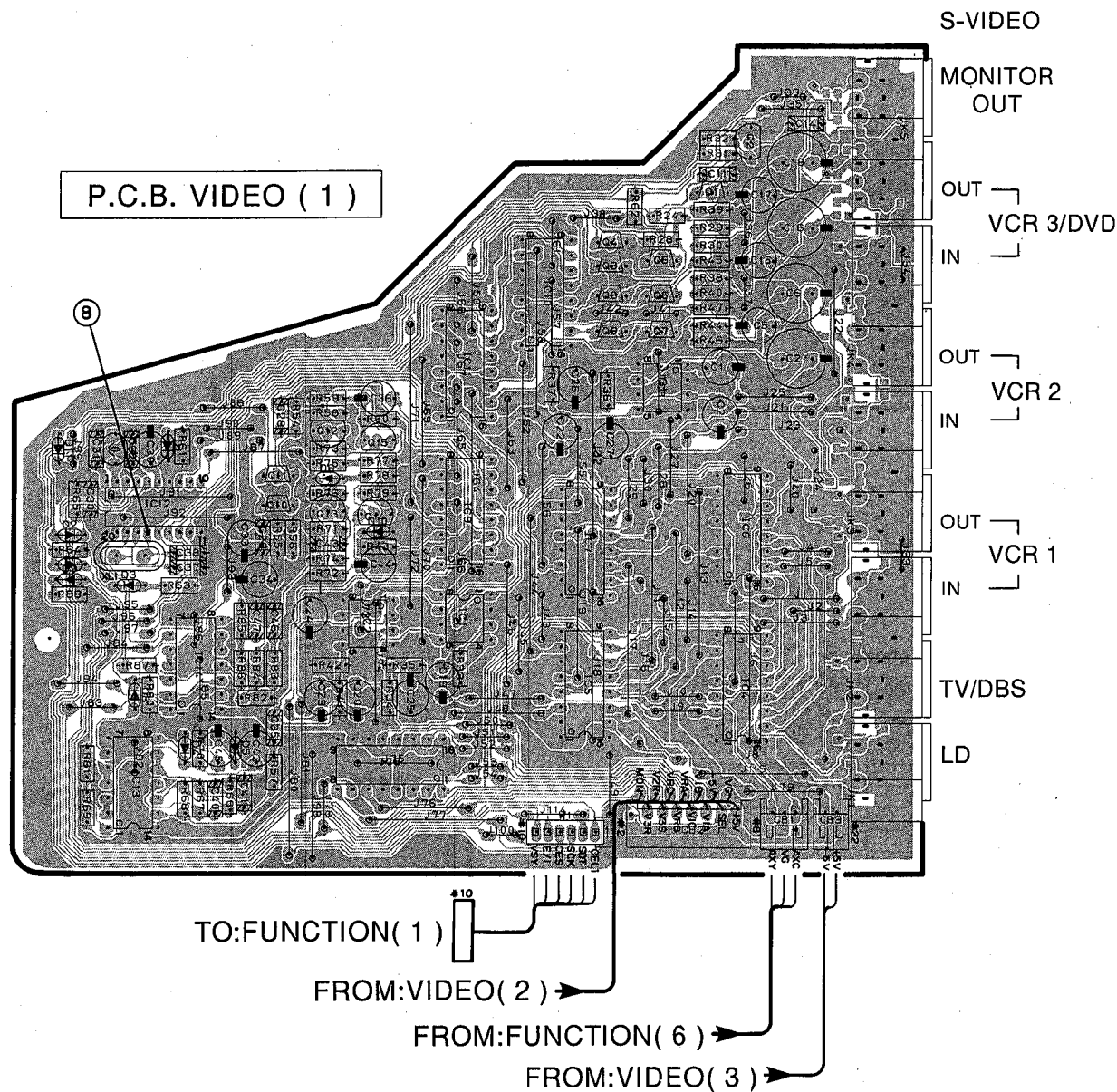

P.C.B. VIDEO (5)

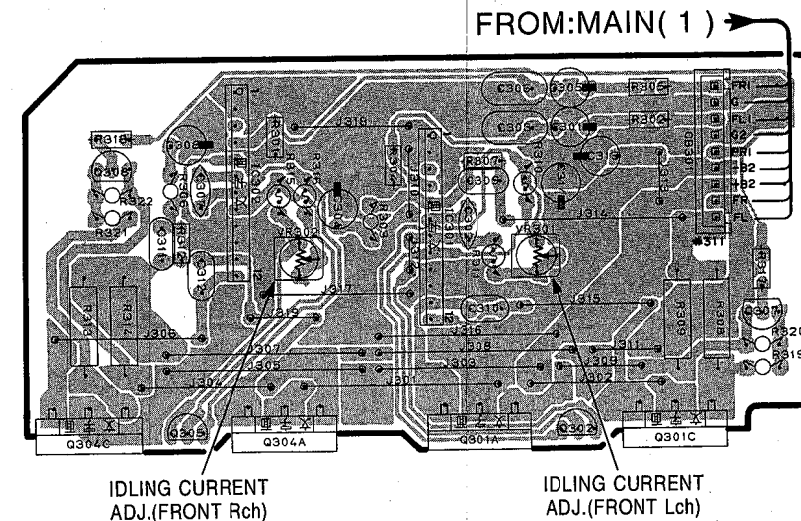

● Semiconductor Location

Ref. No.	Location	Ref. No.	Location	Ref. No.	Location	Ref. No.	Location
IC 1	B3	IC 13	A3	Q 1	C2	Q 13	B3
IC 2	B3	IC 14	B3	Q 2	C2	Q 14	B3
IC 3	C2	IC 301	F5	Q 3	C2	Q 15	B2
IC 4	C3	IC 302	F5	Q 4	C2	Q301A	F6
IC 5	C3			Q 5	C2	Q301C	G6
IC 6	C3			Q 6	C2	Q 302	G6
IC 7	C3			Q 7	C2	Q304A	F6
IC 8	B3			Q 8	C2	Q304C	E6
IC 9	B3			Q 9	C2	Q 305	E6
IC 10	C2			Q 10	B3	Q 307	G5
IC 11	B2			Q 11	B2	Q 308	E5
IC 12	A3			Q 12	B2		

5

6

PRINTED CIRCUIT BOARD (Foil side)

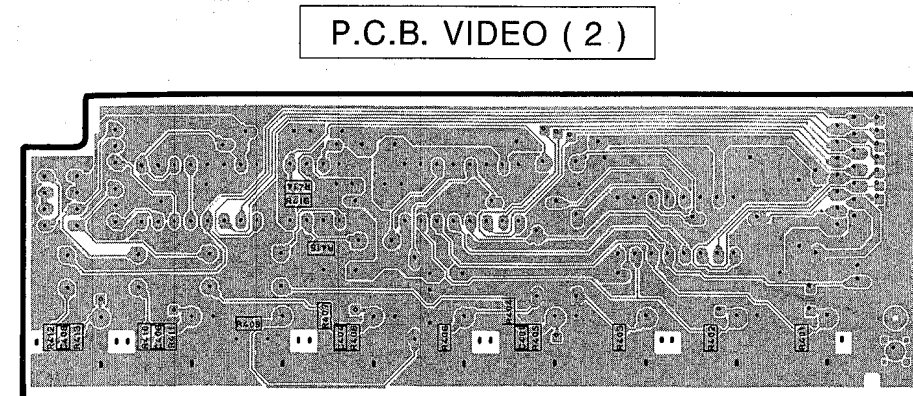
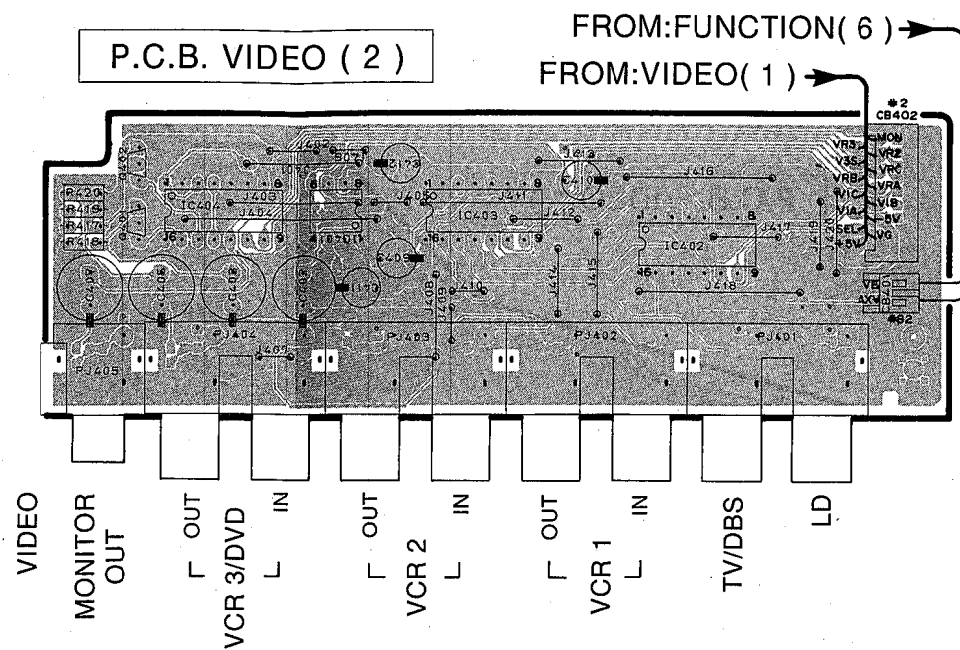

Semiconductor Location

Ref. No.	Location	Ref. No.	Location
IC 201	A5	Q 401	B2
IC 202	B5	Q 402	B2
IC 203	C5		
IC 204	C5		
IC 205	B5		
IC 206	B5		
IC 207	B5		
IC 401	C2		
IC 402	D2		
IC 403	C2		
IC 404	B2		

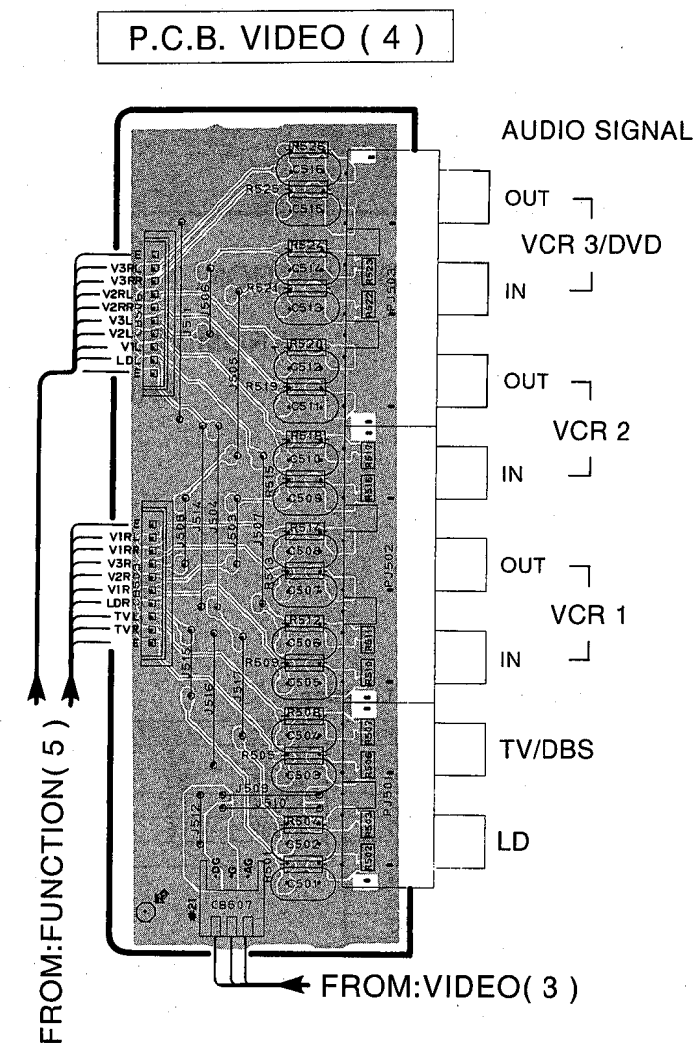
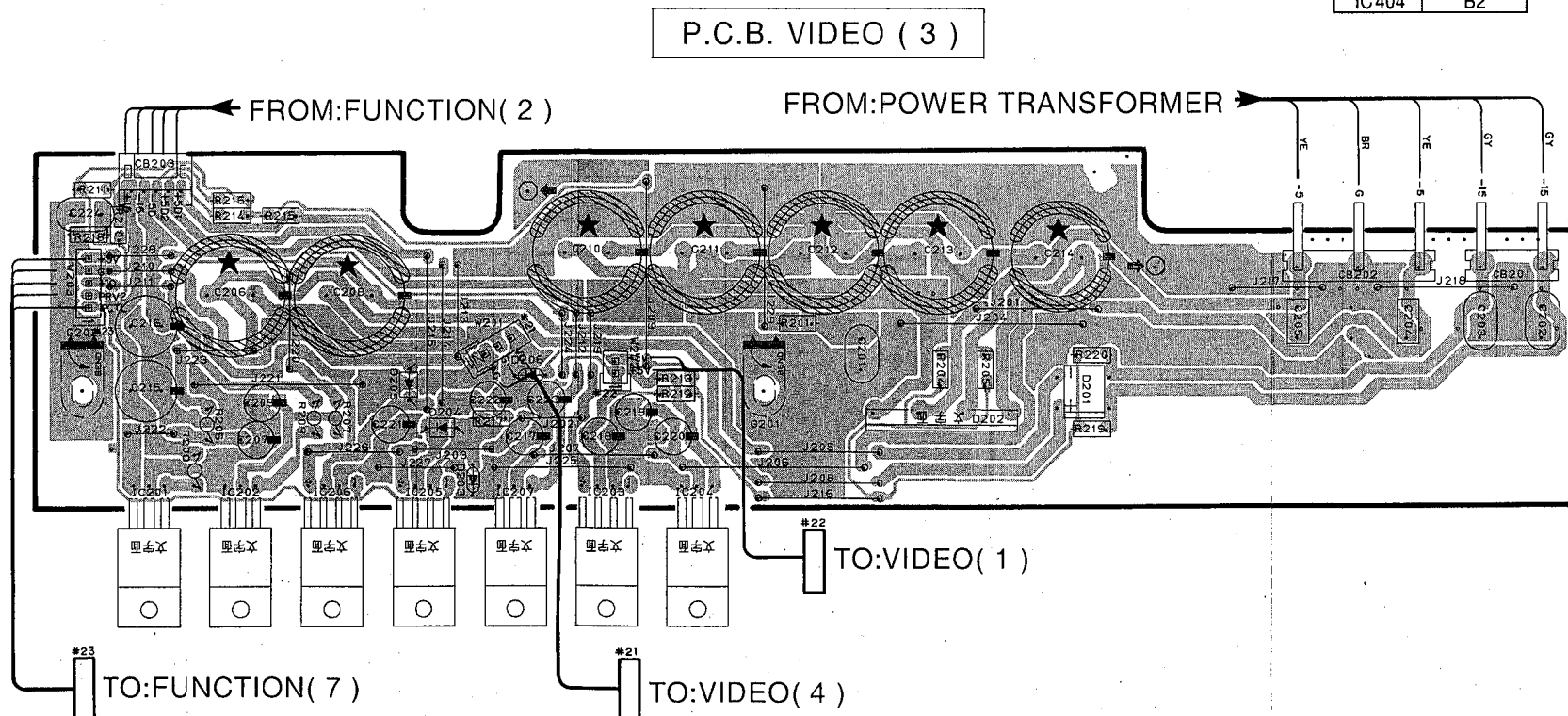

REMOTE CONTROL TRANSMITTER

SCHEMATIC DIAGRAM

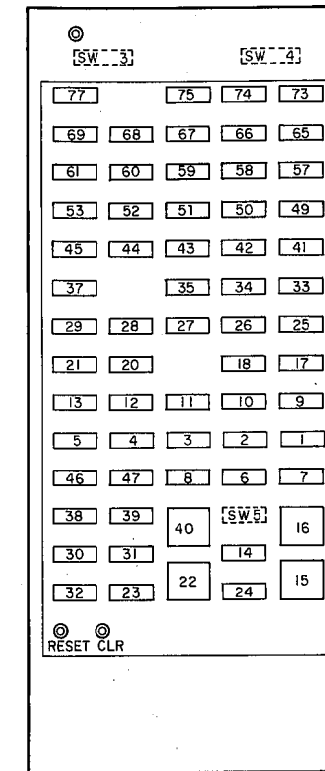
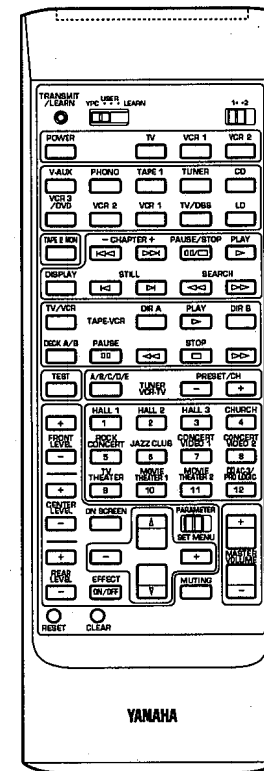
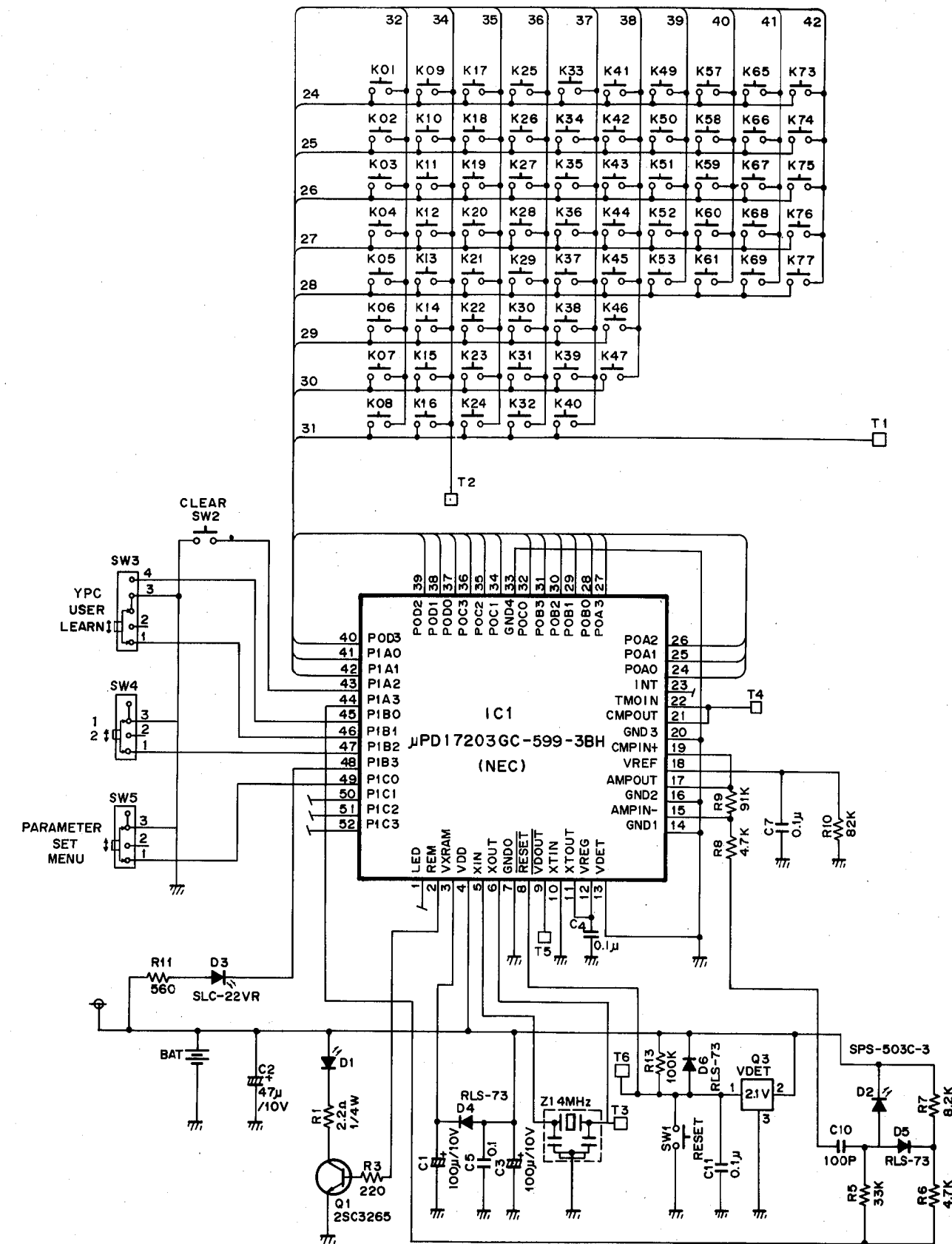

KEY No.	CONTROL CODE	FUNCTION
SW 4	1 2	
77	7D-8F	POWER
75	—	TV
74	—	VCR 1
73	—	VCR 2
69	7D-8A	INPUT V-AUX
68	7D-88	PHONO
67	7D-8B	TAPE1
66	7D-89	TUNER
65	7D-87	CD
60	7D-82	VCR 2
59	7D-81	VCR 1
58	7D-84	TV/DBS
57	7D-83	LD
53	7D-8C	TAPE2 MON
52	7A-0B 7C-02	SKIP/CHAPTER -
51	7A-0A 7C-03	SKIP/CHAPTER +
50	7A-09 7C-04	PAUSE/STOP
49	7A-08 7C-05	PLAY
45	7A-0A 7C-13	DISPLAY

KEY No.	CONTROL CODE	FUNCTION
SW 4	1 2	
44	— 7C-0A	STILL ◀
43	— 7C-0B	STILL ▶
42	7A-0D 7C-06	SEARCH ◀◀
41	7A-0C 7C-07	SEARCH ▶▶
37	—	TV/VCR
35	7A-07	DIR A
34	7A-00	PLAY
33	7A-40	DIR B
29	7A-06	DECK A/B
28	—	PAUSE
27	7A-01	◀◀
26	7A-03	STOP
25	7A-02	▶▶
21	7D-CA	TEST
20	7A-12	TUNER A/B/C/D/E
18	7A-11	PRESET -
17	7A-10	PRESET +
13	7D-CD	FRONT LEVEL +
12	7D-D0	PROGRAM 1
11	7D-D1	PROGRAM 2

KEY No.	CONTROL CODE	FUNCTION
SW 4	1 2	
10	7D-D2	PROGRAM 3
9	7D-D3	PROGRAM 4
5	7D-CE	FRONT LEVEL -
4	7D-D4	PROGRAM 5
3	7D-D5	PROGRAM 6
2	7D-D6	PROGRAM 7
1	7D-D7	PROGRAM 8
46	7D-CB	CENTER LEVEL +
47	7D-D8	PROGRAM 9
8	7D-D9	PROGRAM 10
6	7D-DA	PROGRAM 11
7	7D-DB	PROGRAM 12
38	7D-CC	CENTER LEVEL -
39	7D-C2	ON SCREEN
16	7D-8D	MASTER VOLUME +
30	7D-C8	REAR LEVEL +
32	7D-C9	REAR LEVEL -
23	7D-C1	EFFECT ON/OFF
24	7D-94	MUTING -20dB
15	7D-8E	MASTER VOLUME -

KEY No.	CONTROL CODE	FUNCTION
SW 5	PARAMETER SET MENU	
40	7D-C5 7D-9D	PARAMETER SET MENU ↑
31	7D-C7 7D-9F	PARAMETER SET MENU -
14	7D-C6 7D-9E	PARAMETER SET MENU +
22	7D-C4 7D-9C	PARAMETER SET MENU ↓

■ BLOCK DIAGRAM

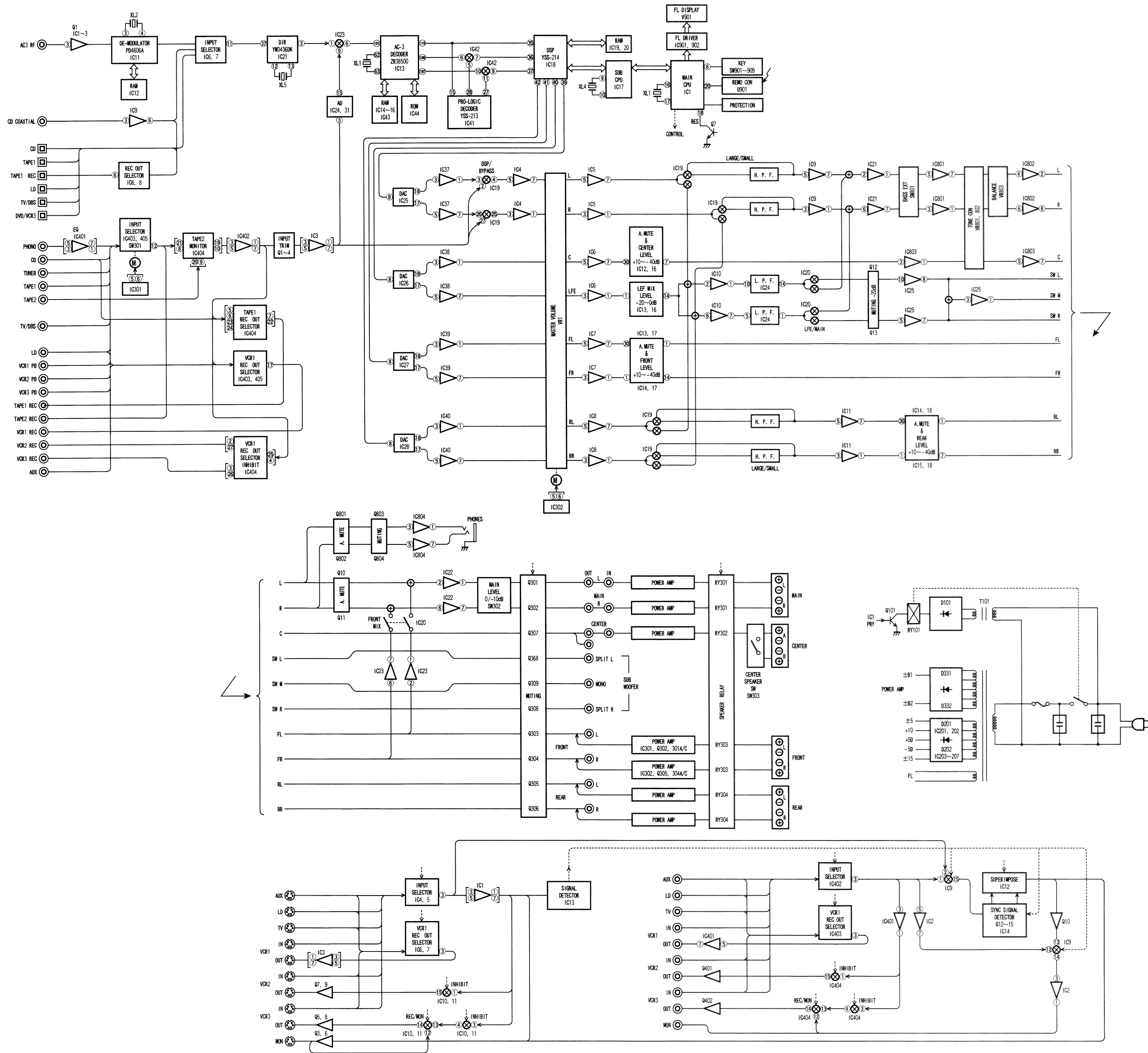

SCHEMATIC DIAGRAM

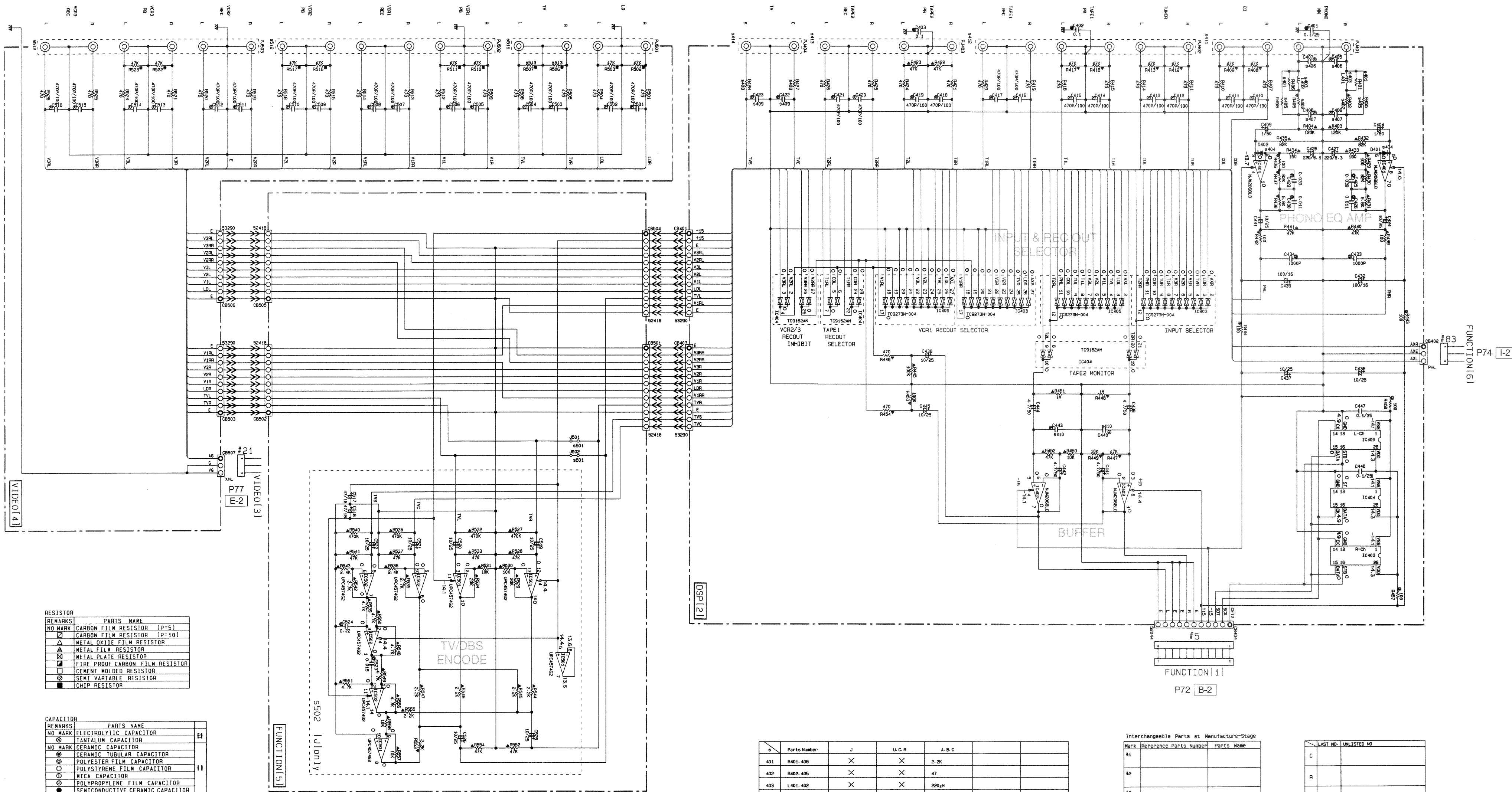

RESISTOR

REMARKS	PARTS NAME
NO MARK	CARBON FILM RESISTOR (P=5)
□	CARBON FILM RESISTOR (P=10)
△	METAL OXIDE FILM RESISTOR
▲	METAL FILM RESISTOR
⊠	METAL PLATE RESISTOR
■	FIRE PROOF CARBON FILM RESISTOR
□	CEMENT MOUNTED RESISTOR
○	SEMI VARIABLE RESISTOR
●	CHIP RESISTOR

CAPACITOR

REMARKS	PARTS NAME
NO MARK	ELECTROLYTIC CAPACITOR
□	TANTALUM CAPACITOR
○	CERAMIC CAPACITOR
●	CERAMIC TUBULAR CAPACITOR
⊙	POLYESTER FILM CAPACITOR
○	POLYSTYRENE FILM CAPACITOR
⊖	MICA CAPACITOR
⊕	POLYPROPYLENE FILM CAPACITOR
●	SEMICONDUCTIVE CERAMIC CAPACITOR

s	Parts Number	J	U.C	R	A	B	G
511	PJ501	VU14480	W72590	W72590	W72590	W72590	W72590
512	PJ502-503	VU14480	W72600	W72600	W72600	W72600	W72600
513	RS06-507	X	47K	47K	47K	47K	47K
514							
515							
516							
PWB	XR488	XR489	XR490	XR491	XR491	XR492	
PCB	VU17860	VU17870	VU17880	VU17890	VU17900	VU18430	

s	Parts Number	J	U.C.R	A.B.G
501	J501-502	X	○	○
502	3-1 Encoder	○	X	X
503				
504				
505				
506				
PWB	XR484	XR484	XR484	
PCB	VU17760	VU17770	VU17780	

s	Parts Number	J	U.C.R	A.B.G
401	RA01-406	X	X	2-2K
402	RA02-406	X	X	47
403	LA01-402	X	X	220μH
404	DA01-402	X	X	15S133-HSS104TD
405	RA05-456	47	47	X
406	CA05-407	100P/100	100P/100	X
407	CA06-408	220P/100	220P/100	390P/100
408	RA27-428	470	X	X
409	CA22-423	470P/100	X	X
410	CA40-443	100P/100	100P/100	220P/100
411	PJ401	WK42170	WK42150	WK42150
412	PJ402	VU14470	W75060	W75060
413	PJ403	VK17740	VJ69630	VJ69630
414	PJ404	VL84390	X	X
415				
416				
417				
418				
419				
420				
421				
PWB	XR487	XR487	XR487	
PCB	VU17830	VU17840	VU17850	

Interchangeable Parts at Manufacture-Stage

Mark	Reference Parts Number	Parts Name
81		
82		
83		
84		
85		
86		

LAST NO.	UNLISTED NO
C	
R	
Q	
D	
IC	
CB	

NOTICE
 (J)..... Japanese model
 (U)..... U.S.A model
 (C)..... Canadian model
 (A)..... Australian model
 (G)..... European model
 (B)..... British model
 (R)..... General model
 (P)..... RP model

* All voltage are measured with a 10MΩ/V DC electric volt meter.
 * Components having special characteristics are marked Δ and must be replaced with parts having specifications equal to those originally installed.
 * Schematic diagram is subject to change without notice.

SCHEMATIC DIAGRAM ① and ② : TEST POINT WAVEFORMS (See page 22)

RESISTOR		CAPACITOR	
REMARKS	PARTS NAME	REMARKS	PARTS NAME
NO MARK	CARBON FILM RESISTOR (P-5)	NO MARK	ELECTRONIC CAPACITOR
△	CARBON FILM RESISTOR (P-10)	△	TANTALUM CAPACITOR
△	METAL FILM RESISTOR (P-10)	△	CERAMIC TUBULAR CAPACITOR
△	METAL FILM RESISTOR	○	POLYESTER FILM CAPACITOR
△	FILM PROOF CARBON FILM RESISTOR	○	POLYSTYRENE FILM CAPACITOR
△	CEMENT HOLED RESISTOR	○	MICA CAPACITOR
△	SEMI VARIABLE RESISTOR	○	POLYPROPYLENE FILM CAPACITOR
■	CHIP RESISTOR	■	SEMI CONDUCTIVE CERAMIC CAPACITOR

NOTICE
 (J)..... Japanese model
 (U)..... U.S.A model
 (C)..... Canadian model
 (A)..... Australian model
 (G)..... European model
 (E)..... SP 1st SPY model
 (P)..... General model
 (P)..... HP model

LAST NO. REGISTERED	DATE	DESCRIPTION
C	148	6-10-127-129
D	106	5-24-95-97-98-91-103-106
D	13	
D	12	
IC	25	
CB	11	

Interchangeable Parts at Manufacture Stage	Part No.	Reference Part No.	Part Name
41	10010	10010	ICP1010
42	10010	10010	ICP1010
43	10010	10010	ICP1010
44	10010	10010	ICP1010

Circuit No.	U.C.F.	L.S.F.
1	○	○
2	○	○
3	○	○
4	○	○
5	○	○
6	○	○
7	○	○
8	○	○
9	○	○
10	○	○
11	○	○
12	○	○
13	○	○
14	○	○
15	○	○
16	○	○
17	○	○
18	○	○
19	○	○
20	○	○
21	○	○
22	○	○
23	○	○
24	○	○
25	○	○
26	○	○
27	○	○
28	○	○
29	○	○
30	○	○
31	○	○
32	○	○
33	○	○
34	○	○
35	○	○
36	○	○
37	○	○
38	○	○
39	○	○
40	○	○
41	○	○
42	○	○
43	○	○
44	○	○
45	○	○
46	○	○
47	○	○
48	○	○
49	○	○
50	○	○
51	○	○
52	○	○
53	○	○
54	○	○
55	○	○
56	○	○
57	○	○
58	○	○
59	○	○
60	○	○
61	○	○
62	○	○
63	○	○
64	○	○
65	○	○
66	○	○
67	○	○
68	○	○
69	○	○
70	○	○
71	○	○
72	○	○
73	○	○
74	○	○
75	○	○
76	○	○
77	○	○
78	○	○
79	○	○
80	○	○
81	○	○
82	○	○
83	○	○
84	○	○
85	○	○
86	○	○
87	○	○
88	○	○
89	○	○
90	○	○
91	○	○
92	○	○
93	○	○
94	○	○
95	○	○
96	○	○
97	○	○
98	○	○
99	○	○
100	○	○

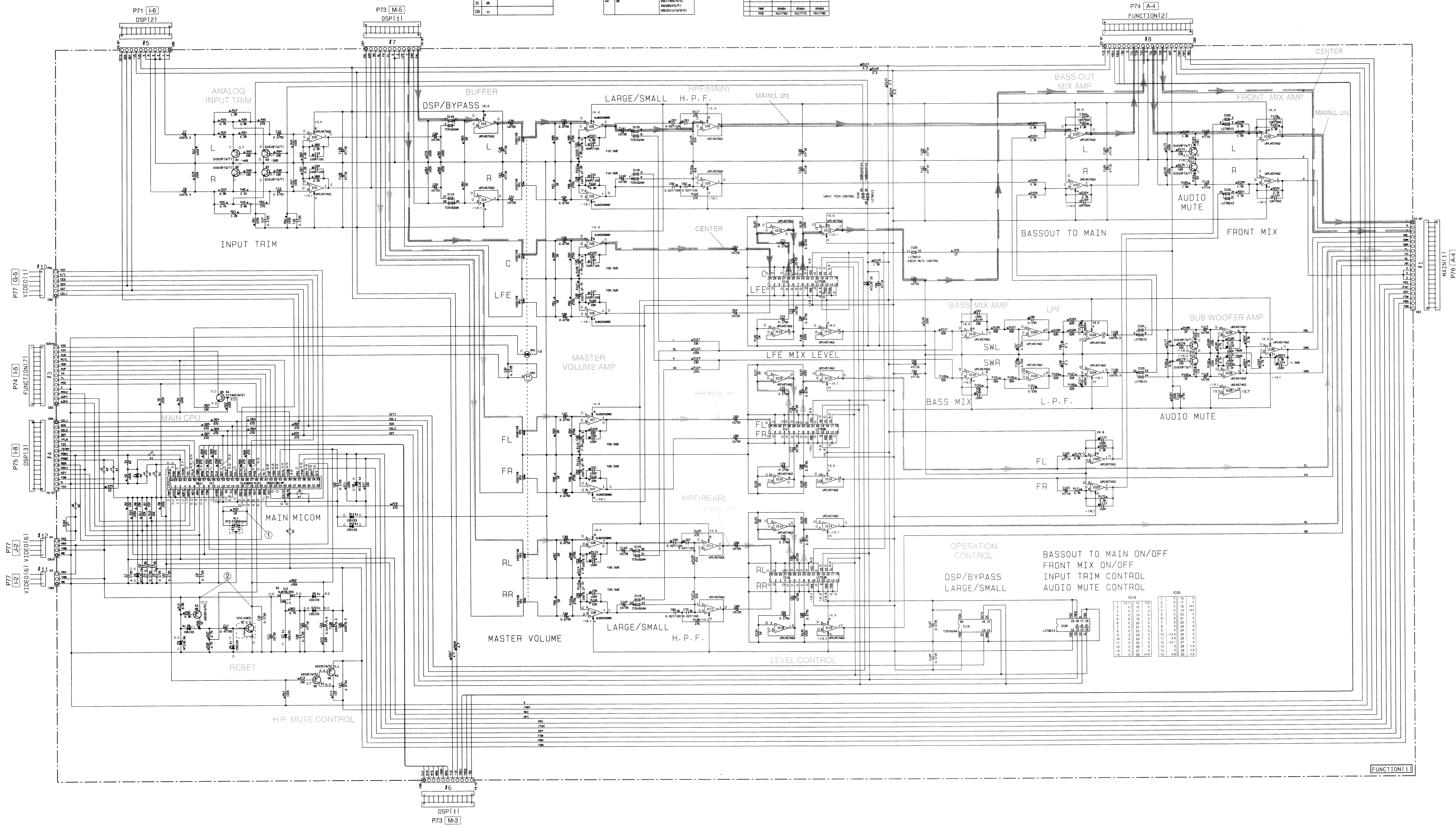

* All voltage are measured with a 10MQ/V DC electric volt meter.
 * Components having special characteristics are marked △ and must be replaced with parts having specifications equal to those originally installed.
 * Schematic diagram is subject to change without notice.

■ SCHEMATIC DIAGRAM ③ to ⑦ : TEST POINT WAVEFORMS (See page 22)

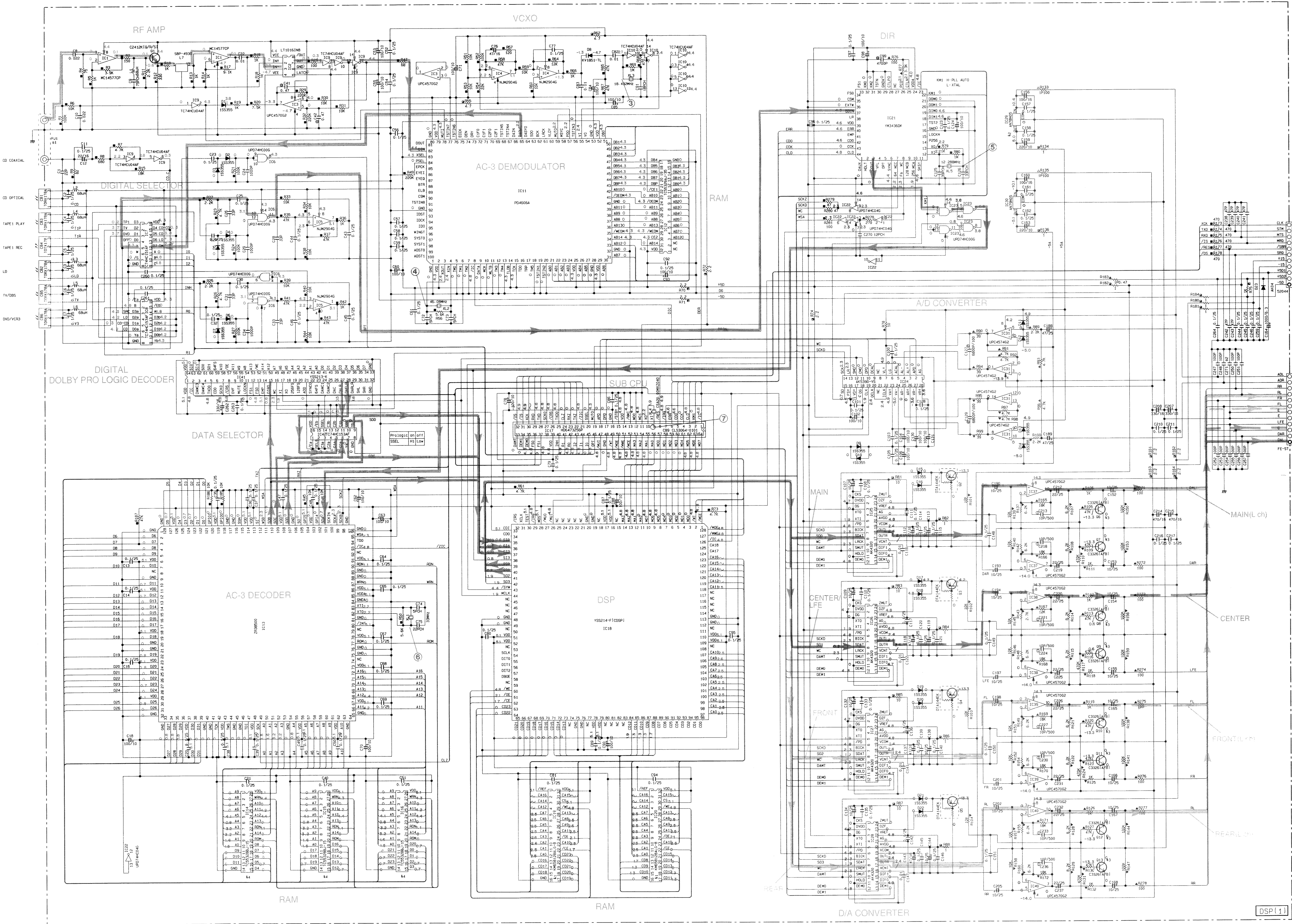

REMARKS	PARTS NAME
NO MARK	CARBON FILM RESISTOR (P=5)
□	CARBON FILM RESISTOR (P=10)
△	METAL OXIDE FILM RESISTOR
▲	METAL FILM RESISTOR
◇	METAL PLATE RESISTOR
○	FIRE PROOF CARBON FILM RESISTOR
●	CEMENT MOLDED RESISTOR
■	SEMI VARIABLE RESISTOR
■	CHIP RESISTOR

REMARKS	PARTS NAME
NO MARK	ELECTROLYTIC CAPACITOR
□	TANTALUM CAPACITOR
○	CERAMIC CAPACITOR
●	CERAMIC TUBULAR CAPACITOR
◇	POLYESTER FILM CAPACITOR
○	POLYSTYRENE FILM CAPACITOR
○	MICA CAPACITOR
○	POLYPROPYLENE FILM CAPACITOR
●	SEMICONDUCTIVE CERAMIC CAPACITOR

NOTICE (mode1)
 (J)..... JAPANESE
 (U)..... U.S.A
 (C)..... CANADIAN
 (R)..... GENERAL
 (A)..... AUSTRALIAN
 (B)..... BRITISH
 (G)..... EUROPEAN
 (L)..... SINGAPORE

Parts Number	J	U.C.R	A.B.G
1	PJ1	VU1430	VU1440 VU1440
2	C21	0.1/25	0.1/25
PCB			
	VU1780	VU1790	VU1785

Mark	Reference Parts Number	Parts Name
41	IC19-20	MM56128A/G-B MM56128A/P-B
42	IC29	AM7805 L7805
43	06-13	2SC3261A/B 2SC3261B
44	IC14-16	TC5538B-15 TC5538B-20 MC6210D-35

ZR38500(IC13) version and peripheral circuit parts
 There are two versions (A2 version and A3 version) of AC-3 decoder ZR38500 (IC13). The A3 version is an upper version of the A2 version and requires less number of peripheral circuit parts. Therefore, be careful for what parts to use when repairing or replacing a faulty part. Use of a wrong part may result in an operation failure. Be sure to check with the table below as it shows the parts that should be used for each version.

ZR38500(IC13) version	ROM (IC44)	SRAM (IC14~16)	SRAM (IC43)	Jumper (J1)	Jumper (J2)	Resistor (R187)	Version displayed when DIAG 11 is used
A2	○	○15nsec	○15nsec	○	×	×	A2+ROM
A3 (used as A2)	○	○15nsec	○15nsec	○	×	×	A2+ROM
A3 (used as A3)	×	○15~35nsec	×	×	○	○47kΩ	A3

Note)
 * "○" in the table means that part is used and "×" means that part is not used.
 * Figures in SRAM columns indicate the access speed required.
 * Since the A3 version is an upper compatible version of the A2 version, if A2 is loaded on A3 as it is, it can operate as the A2 version.

* All voltage are measured with a 10MΩ/V DC electric volt meter.
 * Components having special characteristics are marked △, and must be replaced with parts having specifications equal to those originally installed.
 * Schematic diagram is subject to change without notice.

■ SCHEMATIC DIAGRAM

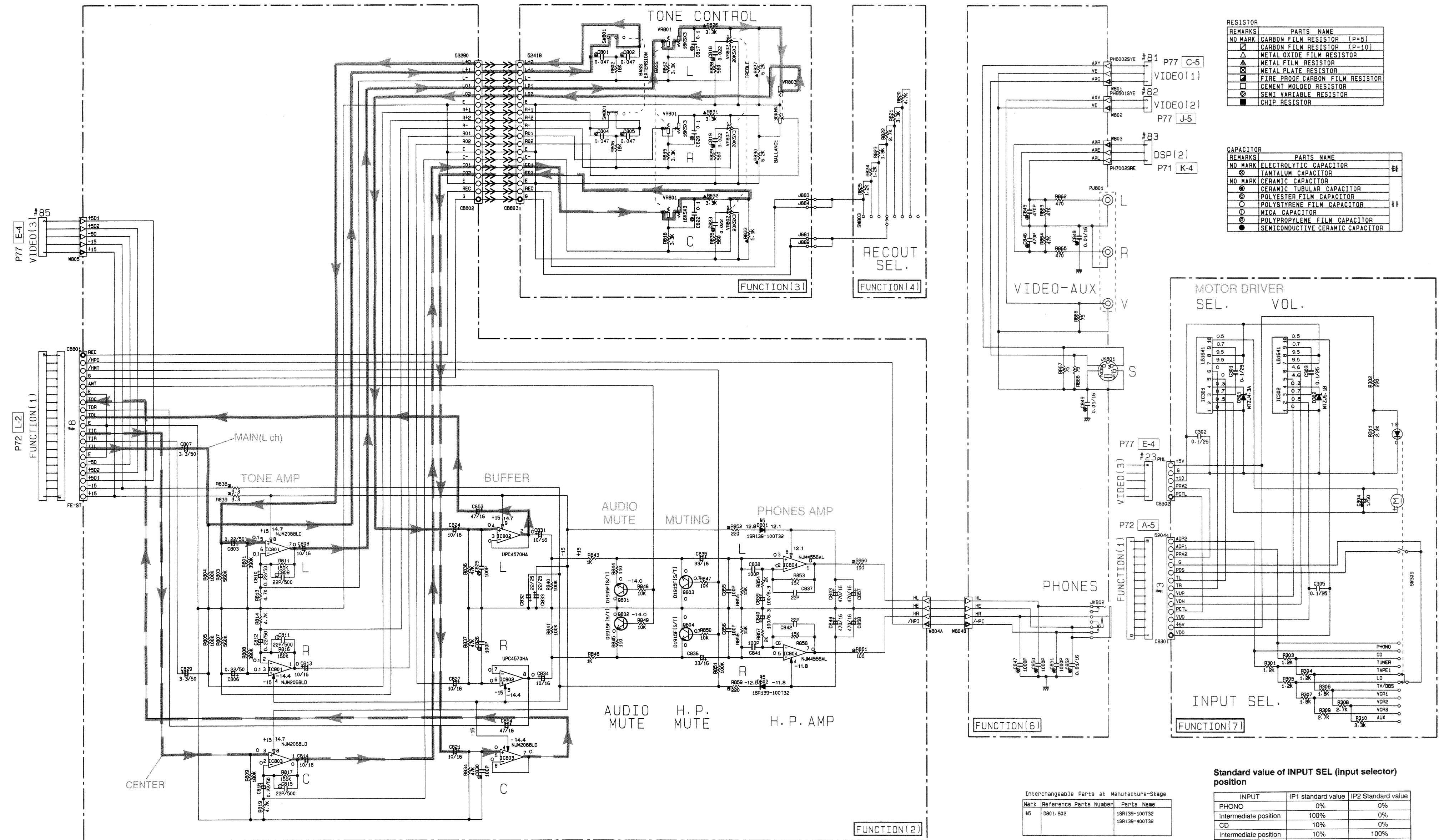

REMARKS	PARTS NAME
NO MARK	CARBON FILM RESISTOR (P=5)
□	CARBON FILM RESISTOR (P=10)
△	METAL OXIDE FILM RESISTOR
▲	METAL FILM RESISTOR
▢	METAL PLATE RESISTOR
■	FIRE PROOF CARBON FILM RESISTOR
□	CEMENT MOLDED RESISTOR
⊗	SEMI VARIABLE RESISTOR
■	CHIP RESISTOR

REMARKS	PARTS NAME
NO MARK	ELECTROLYTIC CAPACITOR
⊗	TANTALUM CAPACITOR
NO MARK	CERAMIC CAPACITOR
⊙	CERAMIC TUBULAR CAPACITOR
⊖	POLYESTER FILM CAPACITOR
⊕	POLYETHYLENE FILM CAPACITOR
⊖	MICA CAPACITOR
⊕	POLYPROPYLENE FILM CAPACITOR
●	SEMICONDUCTIVE CERAMIC CAPACITOR

Interchangeable Parts at Manufacture-Stage

Mark	Reference Parts Number	Parts Name
#5	0801-802	ISR139-100T32
		ISR139-400T32

Standard value of INPUT SEL (input selector) position

INPUT	IP1 standard value	IP2 Standard value
PHONO	0%	0%
Intermediate position	100%	0%
CD	10%	0%
Intermediate position	10%	100%
TUNER	10%	10%
Intermediate position	100%	10%
TAPE1	20%	10%
Intermediate position	20%	100%
LD	20%	20%
Intermediate position	100%	20%
TV/DBS	30%	20%
Intermediate position	30%	100%
VCR3/DVD	30%	30%
Intermediate position	100%	30%
VCR1	40%	30%
Intermediate position	40%	100%
VCR2	40%	40%
Intermediate position	100%	40%
VIDEO AUX	50%	40%

* All voltage are measured with a 10MQ/V DC electric volt meter.
 * Components having special characteristics are marked △, and must be replaced with parts having specifications equal to those originally installed.
 * Schematic diagram is subject to change without notice.

SCHEMATIC DIAGRAM

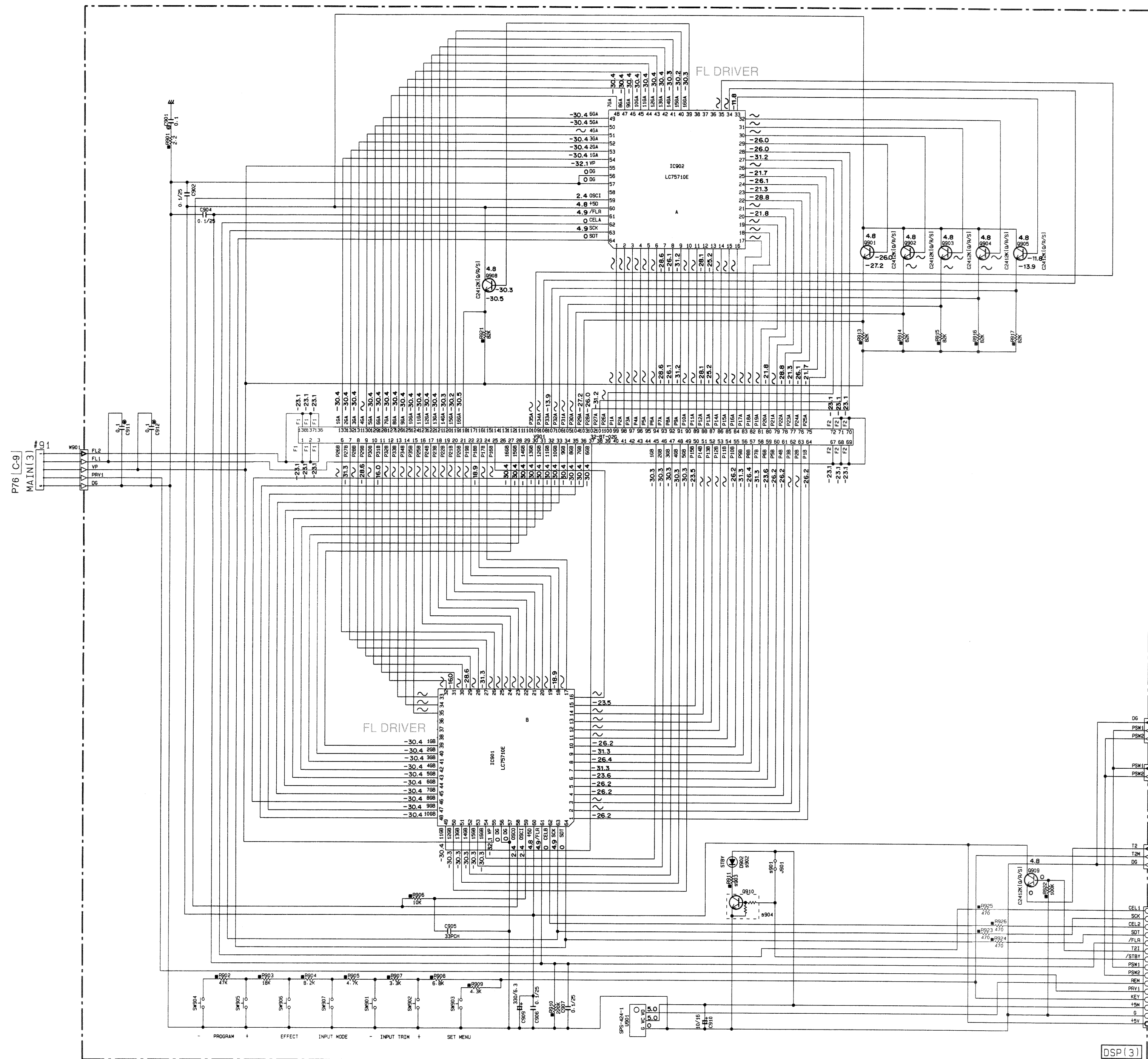

Interchangeable Parts at Manufacture-Stage

Mark	Reference Parts Number	Parts Name
44	D903	SLR-3050CA47 SLR-3250CT31

RESISTOR

REMARKS	PARTS NAME
NO MARK	CARBON FILM RESISTOR (P=5)
□	CARBON FILM RESISTOR (P=10)
△	METAL OXIDE FILM RESISTOR
▲	METAL FILM RESISTOR
⊠	METAL PLATE RESISTOR
■	FIRE PROOF CARBON FILM RESISTOR
⊞	CEMENT MOLDED RESISTOR
⊕	SEMI VARIABLE RESISTOR
●	CHIP RESISTOR

CAPACITOR

REMARKS	PARTS NAME
NO MARK	ELECTROLYTIC CAPACITOR
⊗	TANTALUM CAPACITOR
NO MARK	CERAMIC CAPACITOR
⊙	CERAMIC TUBULAR CAPACITOR
⊖	POLYESTER FILM CAPACITOR
○	POLYSTYRENE FILM CAPACITOR
⊕	MICA CAPACITOR
⊗	POLYPROPYLENE FILM CAPACITOR
●	SEMICONDUCTIVE CERAMIC CAPACITOR

NOTICE

(J)..... Japanese model
 (U)..... U.S.A model
 (C)..... Canadian model
 (A)..... Australian model
 (G)..... European model
 (B)..... British model
 (R)..... General model
 (P)..... RP model

S	Parts Number	J	U-C-R	A-B-G
901	J901	○	○	×
902	D902	×	×	SLR-325VCT31
903	R911	×	×	220
904	Q910	×	×	DTC114ES
905	SW909	KAB0455	KAB0455	V012100
906	W903	V060010	V060010	×
907	W904	×	×	V060180

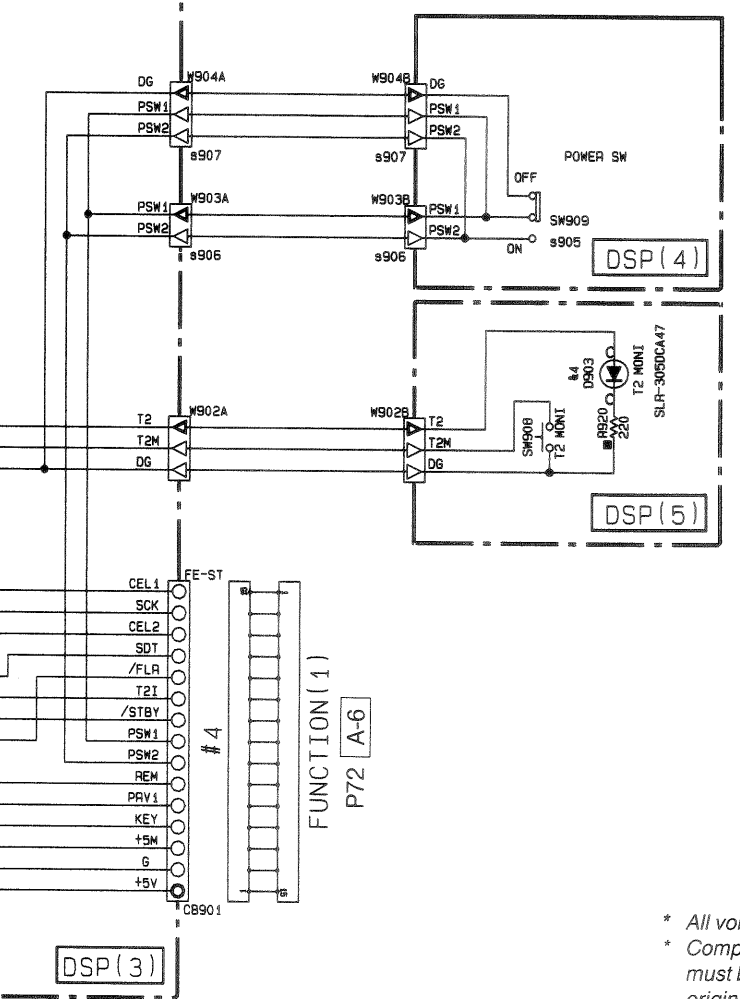

* All voltage are measured with a 10MΩ/V DC electric volt meter.
 * Components having special characteristics are marked △ and must be replaced with parts having specifications equal to those originally installed.
 * Schematic diagram is subject to change without notice.

SCHEMATIC DIAGRAM

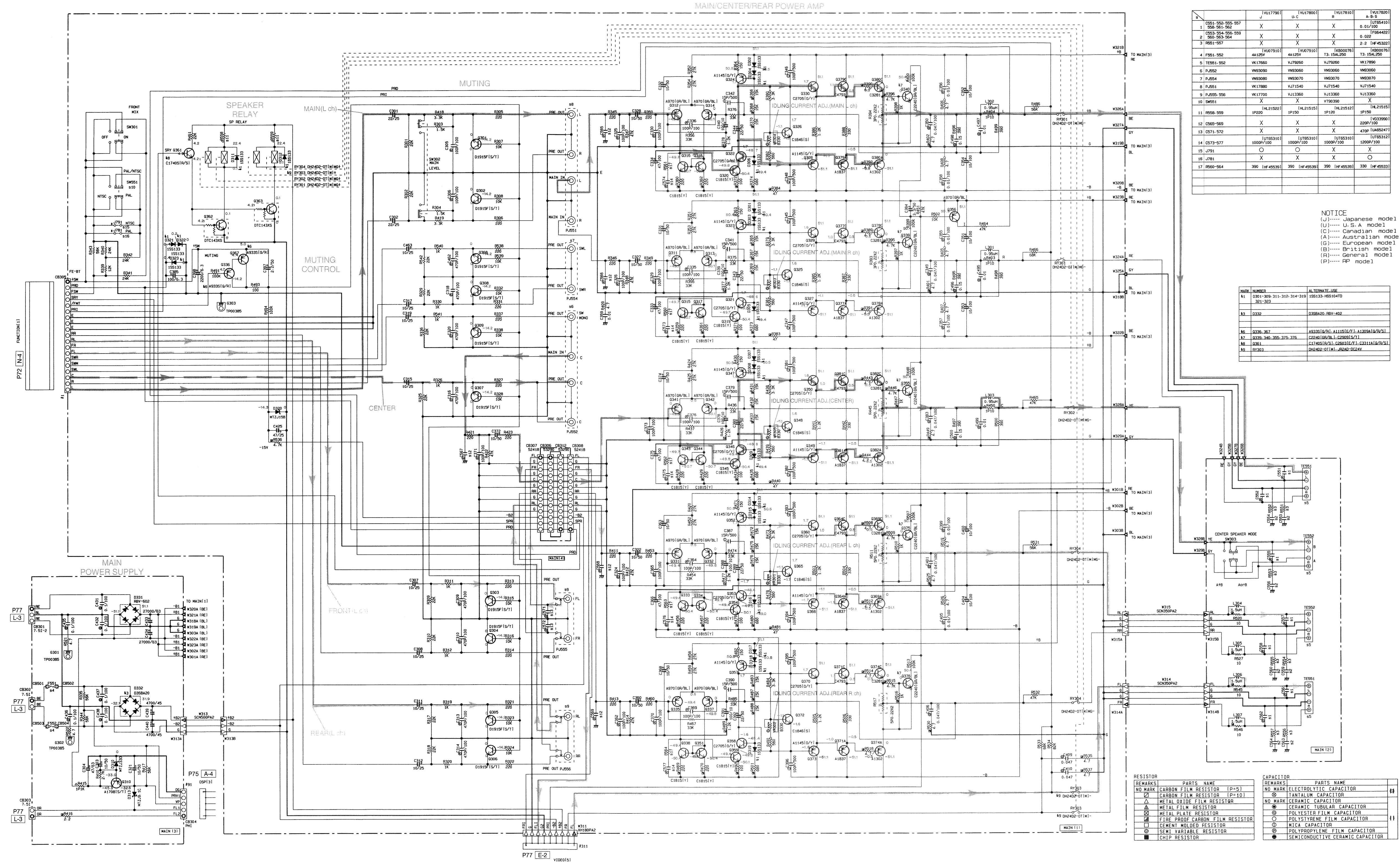

	J	U-C	R	A-B-E
1	C551 565 555 557	X	X	X
2	C553 554 556 559	X	X	X
3	R651 557	X	X	X
4	F551 552	X	X	X
5	T551 552	X	X	X
6	F552	X	X	X
7	F554	X	X	X
8	F551	X	X	X
9	F555 556	X	X	X
10	S551	X	X	X
11	R558 559	X	X	X
12	C556 559	X	X	X
13	C571 572	X	X	X
14	C573 577	X	X	X
15	J591	X	X	X
16	J591	X	X	X
17	R560 564	X	X	X

NOTICE
 (J)..... Japanese model
 (U)..... U.S.A model
 (C)..... Canadian model
 (A)..... Australian model
 (E)..... European model
 (B)..... British model
 (R)..... General model
 (P)..... FP model

MARK	NUMBER	ALTERNATE USE
A1	D301-309-311-312-314-319-321-323	158133-168104TD
B3	D332	D338A20-FBY-602
A6	D336-367	A933012/91-111151E/1-11309A12/9/S1
A7	D339-340-305-375-376	C224016R/BL L-C23061S/1
A8	D361	C174051R/S1, C23031E/1, C2311A12/9/S1
A9	D373	DH2402-011M1-162A2-1624Y

REMARKS	PARTS NAME	REMARKS	PARTS NAME
NO MARK	CARBON FILM RESISTOR (D-S)	NO MARK	ELECTROLYTIC CAPACITOR
△	CARBON FILM RESISTOR (P-10)	∞	FLUX LINK CAPACITOR
▲	METAL OXIDE FILM RESISTOR	⊙	CERAMIC TUBULAR CAPACITOR
⊙	METAL FILM RESISTOR	⊖	POLYESTER FILM CAPACITOR
⊖	METAL PLATE RESISTOR	○	POLYSTYRENE FILM CAPACITOR
⊕	FIBRE PROOF CARBON FILM RESISTOR	⊕	MICA CAPACITOR
⊖	CEMENT MOLDED RESISTOR	⊖	POLYPROPYLENE FILM CAPACITOR
⊕	SEMI VARIABLE RESISTOR	⊕	SEMICONDUCTIVE CERAMIC CAPACITOR
■	CHIP RESISTOR		

* All voltage are measured with a 10MΩ/V DC electric volt meter.
 * Components having special characteristics are marked Δ, and must be replaced with parts having specifications equal to those originally installed.
 * Schematic diagram is subject to change without notice.

■ SCHEMATIC DIAGRAM ⑧ : TEST POINT WAVEFORMS (See page 22)

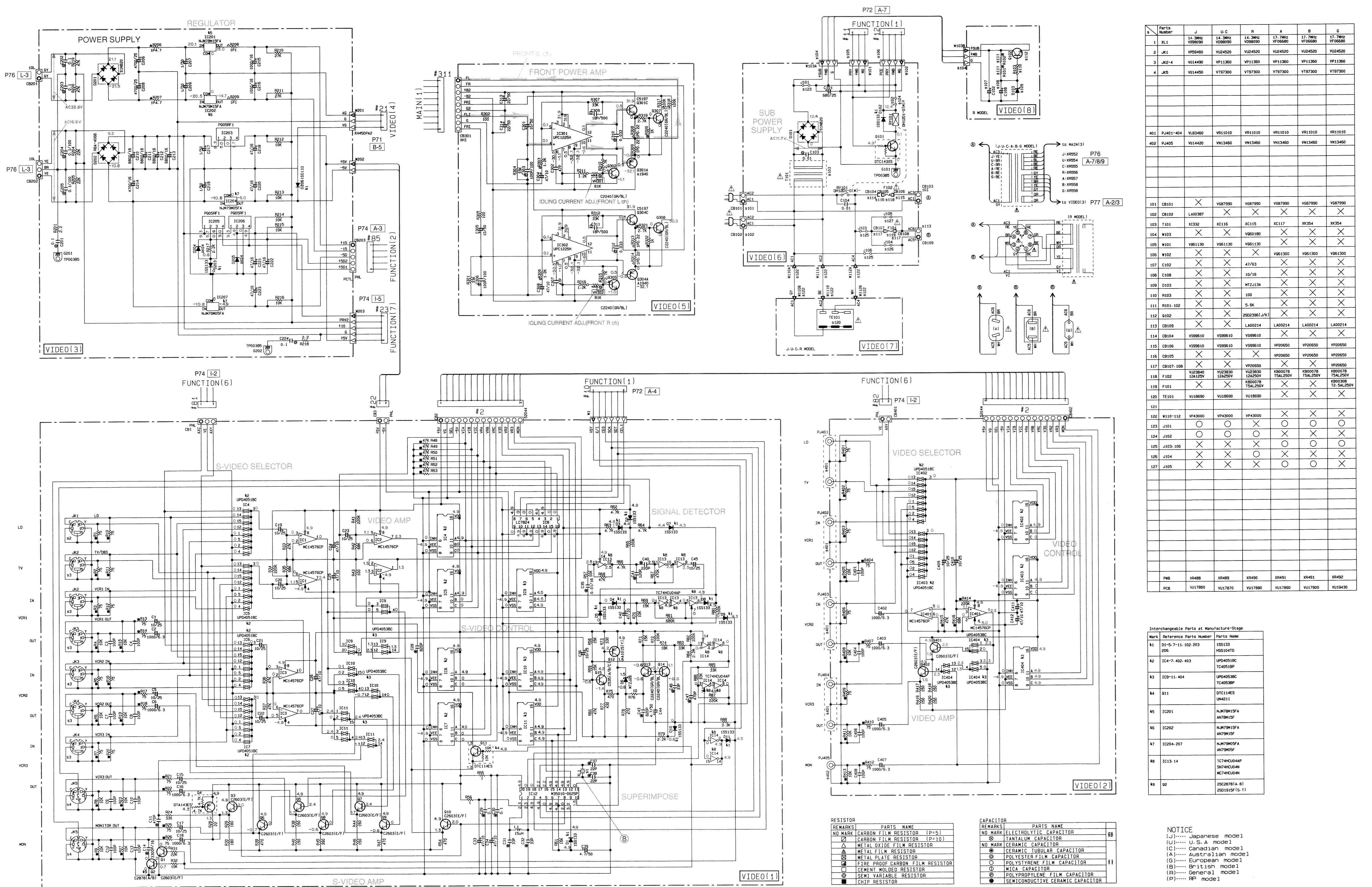

Parts Number	J	U-C	R	A	B	G
1 XL1	V98450	V98450	V98450	V98450	V98450	V98450
2 JK1	V98450	V98450	V98450	V98450	V98450	V98450
3 JK2-4	V98450	V98450	V98450	V98450	V98450	V98450
4 JK5	V98450	V98450	V98450	V98450	V98450	V98450
401 PJ401-404	V98450	V98450	V98450	V98450	V98450	V98450
402 PJ405	V98450	V98450	V98450	V98450	V98450	V98450
101 CB101	V98450	V98450	V98450	V98450	V98450	V98450
102 CB102	V98450	V98450	V98450	V98450	V98450	V98450
103 J103	V98450	V98450	V98450	V98450	V98450	V98450
104 J104	V98450	V98450	V98450	V98450	V98450	V98450
105 J105	V98450	V98450	V98450	V98450	V98450	V98450
106 J106	V98450	V98450	V98450	V98450	V98450	V98450
107 C107	V98450	V98450	V98450	V98450	V98450	V98450
108 C108	V98450	V98450	V98450	V98450	V98450	V98450
109 D109	V98450	V98450	V98450	V98450	V98450	V98450
110 R103	V98450	V98450	V98450	V98450	V98450	V98450
111 R101, 102	V98450	V98450	V98450	V98450	V98450	V98450
112 Q102	V98450	V98450	V98450	V98450	V98450	V98450
113 CB109	V98450	V98450	V98450	V98450	V98450	V98450
114 CB104	V98450	V98450	V98450	V98450	V98450	V98450
115 CB106	V98450	V98450	V98450	V98450	V98450	V98450
116 CB105	V98450	V98450	V98450	V98450	V98450	V98450
117 CB107, 108	V98450	V98450	V98450	V98450	V98450	V98450
118 F102	V98450	V98450	V98450	V98450	V98450	V98450
119 F101	V98450	V98450	V98450	V98450	V98450	V98450
120 TE101	V98450	V98450	V98450	V98450	V98450	V98450
121						
122 J101-112	V98450	V98450	V98450	V98450	V98450	V98450
123 J101	V98450	V98450	V98450	V98450	V98450	V98450
124 J102	V98450	V98450	V98450	V98450	V98450	V98450
125 J103-106	V98450	V98450	V98450	V98450	V98450	V98450
126 J104	V98450	V98450	V98450	V98450	V98450	V98450
127 J105	V98450	V98450	V98450	V98450	V98450	V98450
PHB	V98450	V98450	V98450	V98450	V98450	V98450
PCB	V98450	V98450	V98450	V98450	V98450	V98450

Interchangeable Parts at Manufacture Stage

Mark	Reference Parts Number	Parts Name
K1	D1-5-7-11-102-203	1S5133 HSS104TD
K2	IC4-7, 402, 403	UPD40518C TC40518P
K3	IC09-11, 404	UPD40538C TC40538P
K4	Q11	DTC114ES UN4211
K5	IC201	NM79M15FA AN79M15F
K6	IC202	NM79M15FA AN79M15F
K7	IC204, 207	NM79M5FA AN79M5F
K8	IC13, 14	TC74HC04AP SN74HC04N MC74HC04N
K9	Q2	2SC2678(A, B) 2SD1915(F15-11)

RESISTOR

REMARKS	PARTS NAME
NO MARK	CARBON FILM RESISTOR (P=5)
□	CARBON FILM RESISTOR (P=10)
△	METAL OXIDE FILM RESISTOR
○	METAL FILM RESISTOR
⊙	METAL PLATE RESISTOR
▭	FIRE PROOF CARBON FILM RESISTOR
■	CEMENT MOLDED RESISTOR
◇	SEMI VARIABLE RESISTOR
◆	CHIP RESISTOR

CAPACITOR

REMARKS	PARTS NAME
NO MARK	ELECTROLYTIC CAPACITOR
□	TANTALUM CAPACITOR
○	CERAMIC CAPACITOR
⊙	CERAMIC TUBULAR CAPACITOR
⊖	POLYESTER FILM CAPACITOR
○	POLYSTYRENE FILM CAPACITOR
○	MICA CAPACITOR
⊖	POLYPROPYLENE FILM CAPACITOR
●	SEMICONDUCTIVE CERAMIC CAPACITOR

NOTICE
 (J)..... Japanese model
 (U)..... U.S.A model
 (C)..... Canadian model
 (A)..... Australian model
 (G)..... European model
 (E)..... British model
 (R)..... General model
 (P)..... PP mode

All voltage are measured with a 10MΩ/V DC electric volt meter.
 Components having special characteristics are marked △, and must be replaced with parts having specifications equal to those originally installed.
 Schematic diagram is subject to change without notice.

PARTS LIST

■ ELECTRICAL PARTS

■ WARNING

Components having special characteristics are marked \triangle and must be replaced with parts having specifications equal to those originally installed.

- Carbon resistors (1/6W or 1/4W) are not included in the ELECTRICAL PARTS List. For the parts No. of the carbon resistors, refer to last page.

ABBREVIATIONS IN THIS LIST ARE AS FOLLOWS :

C.A.EL.CHP	: CHIP ALUMI. ELECTROLYTIC CAP	L.EMIT	: LIGHT EMITTING MODULE
C.CE	: CERAMIC CAP	LED.DSPLY	: LED DISPLAY
C.CE.ARRAY	: CERAMIC CAP ARRAY	LED.INFRD	: LED, INFRARED
C.CE.CHP	: CHIP CERAMIC CAP	MODUL.RF	: MODULATOR, RF
C.CE.ML	: MULTILAYER CERAMIC CAP	PHOT.GPL	: PHOTO COUPLER
C.CE.M.CHP	: CHIP MULTILAYER CERAMIC CAP	PHOT.INTR	: PHOTO INTERRUPTER
C.CE.SAFTY	: RECOGNIZED CERAMIC CAP	PHOT.RFLCT	: PHOTO REFLECTOR
C.CE.TUBLR	: CERAMIC TUBULAR CAP	PIN.TEST	: PIN, TEST POINT
C.CE.SMI	: SEMI CONDUCTIVE CERAMIC CAP	PLST.RIVET	: PLASTIC RIVET
C.EL	: ELECTROLYTIC CAP	R.ARRAY	: RESISTOR ARRAY
C.MICA	: MICA CAP	R.CAR	: CARBON RESISTOR
C.ML.FLM	: MULTILAYER FILM CAP	R.CAR.CHP	: CHIP RESISTOR
C.MP	: METALLIZED PAPER CAP	R.CAR.FP	: FLAME PROOF CARBON RESISTOR
C.MYLAR	: MYLAR FILM CAP	R.FUS	: FUSABLE RESISTOR
C.MYLAR.ML	: MULTILAYER MYLAR FILM CAP	R.MTL.CHP	: CHIP METAL FILM RESISTOR
C.PAPER	: PAPER CAPACITOR	R.MTL.FLM	: METAL FILM RESISTOR
C.PLS	: POLYSTYRENE FILM CAP	R.MTL.OXD	: METAL OXIDE FILM RESISTOR
C.POL	: POLYESTER FILM CAP	R.MTL.PLAT	: METAL PLATE RESISTOR
C.POLY	: POLYETHYLENE FILM CAP	RSNR.CE	: CERAMIC RESONATOR
C.PP	: POLYPROPYLENE FILM CAP	RSNR.CRYS	: CRYSTAL RESONATOR
C.TNTL	: TANTALUM CAP	R.TW.CEM	: TWIN CEMENT FIXED RESISTOR
C.TNTL.CHP	: CHIP TANTALUM CAP	R.WW	: WIRE WOUND RESISTOR
C.TRIM	: TRIMMER CAP	SCR.BND.HD	: BIND HEAD B-TITE SCREW
CN	: CONNECTOR	SCR.BW.HD	: BW HEAD TAPPING SCREW
CN.BS.PIN	: CONNECTOR, BASE PIN	SCR.CUP	: CUP TITE SCREW
CN.CANNON	: CONNECTOR, CANNON	SCR.TERM	: SCREW TERMINAL
CN.DIN	: CONNECTOR, DIN	SCR.TR	: SCREW, TRANSISTOR
CN.FLAT	: CONNECTOR, FLAT CABLE	SUPRT.PCB	: SUPPORT, P.C.B.
CN.POST	: CONNECTOR, BASE POST	SURG.PRTCT	: SURGE PROTECTOR
COIL.MX.AM	: COIL, AM MIX	SW.TACT	: TACT SWITCH
COIL.AT.FM	: COIL, FM ANTENNA	SW.LEAF	: LEAF SWITCH
COIL.DT.FM	: COIL, FM DETECT	SW.LEVER	: LEVER SWITCH
COIL.MX.FM	: COIL, FM MIX	SW.MICRO	: MICRO SWITCH
COIL.OUTPT	: OUTPUT COIL	SW.PUSH	: PUSH SWITCH
DIOD.ARRAY	: DIODE ARRAY	SW.RT.ENC	: ROTARY ENCODER
DIODE.BRG	: DIODE BRIDGE	SW.RT.MTR	: ROTARY SWITCH WITH MOTOR
DIODE.CHP	: CHIP DIODE	SW.RT	: ROTARY SWITCH
DIODE.VAR	: VARACTOR DIODE	SW.SLIDE	: SLIDE SWITCH
DIOD.Z.CHP	: CHIP ZENER DIODE	TERM.SP	: SPEAKER TERMINAL
DIODE.ZENR	: ZENER DIODE	TERM.WRAP	: WRAPPING TERMINAL
DSCR.CE	: CERAMIC DISCRIMINATOR	THRMST.CHP	: CHIP THERMISTOR
FER.BEAD	: FERRITE BEADS	TR.CHP	: CHIP TRANSISTOR
FER.CORE	: FERRITE CORE	TR.DGT	: DIGITAL TRANSISTOR
FET.CHP	: CHIP FET	TR.DGT.CHP	: CHIP DIGITAL TRANSISTOR
FL.DSPLY	: FLUORESCENT DISPLAY	TRANS	: TRANSFORMER
FLTR.CE	: CERAMIC FILTER	TRANS.PULS	: PULSE TRANSFORMER
FLTR.COMB	: COMB FILTER MODULE	TRANS.PWR	: POWER TRANSFORMER ASS'y
FLTR.LC.RF	: LC FILTER, EMI	TUNER.AM	: TUNER PACK, AM
GND.MTL	: GROUND PLATE	TUNER.FM	: TUNER PACK, FM
GND.TERM	: GROUND TERMINAL	TUNER.PK	: FRONT-END TUNER PACK
HOLDER.FUS	: FUSE HOLDER	VR	: ROTARY POTENTIOMETER
IC.PRTCT	: IC PROTECTOR	VR.MTR	: POTENTIOMETER WITH MOTOR
JUMPER.CN	: JUMPER CONNECTOR	VR.SW	: POTENTIOMETER WITH ROTARY SW
JUMPER.TST	: JUMPER, TEST POINT	VR.SLIDE	: SLIDE POTENTIOMETER
L.DTCT	: LIGHT DETECTING MODULE	VR.TRIM	: TRIMMER POTENTIOMETER

Note) Those parts marked with "#" are not included in the P.C.B. ass'y.

P.C.B. DSP

Schm Ref.	PART NO.	Description
* VU178400	P. C. B.	DSP(UCR)
* VU178500	P. C. B.	DSP(ABG)
CB1	VT620100	L. DTCT 1P TORX178A
CB2	VT620100	L. DTCT 1P TORX178A
CB3	VT620100	L. DTCT 1P TORX178A
* CB4	VT707200	L. EMIT TOTX178
CB5	VT620100	L. DTCT 1P TORX178A
CB6	VT620100	L. DTCT 1P TORX178A
* CB7	VQ044500	CN. BS. PIN 11P
CB8	VP360400	CN. BS. PIN 12P
CB9	VG904000	SOCKET. IC CLC3064-0101
CB401	VQ963300	CN. BS. PIN 12P
CB402	VB858200	CN. BS. PIN 3P
CB403	VQ963300	CN. BS. PIN 12P
* CB404	VQ044500	CN. BS. PIN 11P
* CB901	VP360700	CN. BS. PIN 15P
C1	UB051220	C. CE. M. CHP 22pF 50V
C2	UB245100	C. CE. M. CHP 0.1uF 25V
C3	UB245100	C. CE. M. CHP 0.1uF 25V
C4	UB245100	C. CE. M. CHP 0.1uF 25V
C5	UB245100	C. CE. M. CHP 0.1uF 25V
C6	UB245100	C. CE. M. CHP 0.1uF 25V
C7	UB245100	C. CE. M. CHP 0.1uF 25V
C8	UB044220	C. CE. M. CHP 0.022uF 50V
C9	VJ901600	C. CE. M. CHP 75pF 50V
C10	UB044220	C. CE. M. CHP 0.022uF 50V
C11	UB245100	C. CE. M. CHP 0.1uF 25V
C12	Vi846000	C. EL 22uF 63V
C13	UB245100	C. CE. M. CHP 0.1uF 25V
C14	UB245100	C. CE. M. CHP 0.1uF 25V
C16	UB245100	C. CE. M. CHP 0.1uF 25V
C18	Vi841800	C. EL 100uF 10V
C20	UB245100	C. CE. M. CHP 0.1uF 25V
C21	UB245100	C. CE. M. CHP 0.1uF 25V
C22	UB044100	C. CE. M. CHP 0.01uF 50V
C23	UB245100	C. CE. M. CHP 0.1uF 25V
C24	UB013100	C. CE. M. CHP 1000pF 50V
C25	UB245100	C. CE. M. CHP 0.1uF 25V
C26	UB051330	C. CE. M. CHP 33pF 50V
C27	UB245100	C. CE. M. CHP 0.1uF 25V
C28	UB051330	C. CE. M. CHP 33pF 50V
C29	UB013100	C. CE. M. CHP 1000pF 50V
C30	UB245100	C. CE. M. CHP 0.1uF 25V
C31	UB051330	C. CE. M. CHP 33pF 50V
C32	UB245100	C. CE. M. CHP 0.1uF 25V
C33	UB051330	C. CE. M. CHP 33pF 50V
C34	UB013100	C. CE. M. CHP 1000pF 50V
C35	UB245100	C. CE. M. CHP 0.1uF 25V
C36	UB245100	C. CE. M. CHP 0.1uF 25V
C37	UB245100	C. CE. M. CHP 0.1uF 25V
C38	UB245100	C. CE. M. CHP 0.1uF 25V
C39	UB245100	C. CE. M. CHP 0.1uF 25V
C40	UB245100	C. CE. M. CHP 0.1uF 25V

* New Parts

Schm Ref.	PART NO.	Description
C41	VR169200	C. MYLAR. ML ECQ-VIH474JL3
C42	VR169200	C. MYLAR. ML ECQ-VIH474JL3
C43	UB245100	C. CE. M. CHP 0.1uF 25V
C44	UB245100	C. CE. M. CHP 0.1uF 25V
C45	UB245100	C. CE. M. CHP 0.1uF 25V
C46	UB245100	C. CE. M. CHP 0.1uF 25V
C47	UB245100	C. CE. M. CHP 0.1uF 25V
C48	UB245100	C. CE. M. CHP 0.1uF 25V
C49	UB245100	C. CE. M. CHP 0.1uF 25V
C50	UB245100	C. CE. M. CHP 0.1uF 25V
C51	UB245100	C. CE. M. CHP 0.1uF 25V
C52	UB245100	C. CE. M. CHP 0.1uF 25V
C53	Vi841800	C. EL 100uF 10V
C54	UB245100	C. CE. M. CHP 0.1uF 25V
C55	Vi841800	C. EL 100uF 10V
C56	UB245100	C. CE. M. CHP 0.1uF 25V
C57	UB245100	C. CE. M. CHP 0.1uF 25V
C58	UB245100	C. CE. M. CHP 0.1uF 25V
C59	UB245100	C. CE. M. CHP 0.1uF 25V
C60	Vi841800	C. EL 100uF 10V
C61	UB245100	C. CE. M. CHP 0.1uF 25V
C62	Vi841800	C. EL 100uF 10V
C63	Vi841800	C. EL 100uF 10V
C64	UB245100	C. CE. M. CHP 0.1uF 25V
C65	UB245100	C. CE. M. CHP 0.1uF 25V
C67	UB245100	C. CE. M. CHP 0.1uF 25V
C68	UB245100	C. CE. M. CHP 0.1uF 25V
C69	UB245100	C. CE. M. CHP 0.1uF 25V
C70	Vi841800	C. EL 100uF 10V
C71	Vi841800	C. EL 100uF 10V
C72	VJ899000	C. CE. M. CHP 5pF 50V
C73	VJ899000	C. CE. M. CHP 5pF 50V
C74	VJ899000	C. CE. M. CHP 5pF 50V
C75	VJ900300	C. CE. M. CHP 22pF 50V
C76	UN837470	C. EL 47uF 16V
C77	UB245100	C. CE. M. CHP 0.1uF 25V
C78	Vi841800	C. EL 100uF 10V
C79	UB245100	C. CE. M. CHP 0.1uF 25V
C80	UB245100	C. CE. M. CHP 0.1uF 25V
C81	UB245100	C. CE. M. CHP 0.1uF 25V
C82	UB044100	C. CE. M. CHP 0.01uF 50V
C83	UB044100	C. CE. M. CHP 0.01uF 50V
C84	Vi841800	C. EL 100uF 10V
C85	Vi841800	C. EL 100uF 10V
C86	UB245100	C. CE. M. CHP 0.1uF 25V
C87	UB245100	C. CE. M. CHP 0.1uF 25V
C88	Vi841800	C. EL 100uF 10V
C89	UB245100	C. CE. M. CHP 0.1uF 25V
C90	Vi841800	C. EL 100uF 10V
C91	VJ900100	C. CE. M. CHP 18pF 50V
C92	UB245100	C. CE. M. CHP 0.1uF 25V
C93	Vi841800	C. EL 100uF 10V
C94	UB245100	C. CE. M. CHP 0.1uF 25V

* New Parts

DSP-A3090

P.C.B. DSP

Schm Ref.	PART NO.	Description		
C95	UB245100	C. CE. M. CHP	0.1uF	25V
C96	UB245100	C. CE. M. CHP	0.1uF	25V
C97	UB245100	C. CE. M. CHP	0.1uF	25V
C98	Vi841800	C. EL	100uF	10V
C99	UA653470	C. MYLAR	4700pF	50V
C100	UB245100	C. CE. M. CHP	0.1uF	25V
C101	UB245100	C. CE. M. CHP	0.1uF	25V
C102	Vi841800	C. EL	100uF	10V
C103	UB245100	C. CE. M. CHP	0.1uF	25V
C104	Vi841800	C. EL	100uF	10V
C105	UB245100	C. CE. M. CHP	0.1uF	25V
C106	Vi841800	C. EL	100uF	10V
C107	Vi845900	C. EL	10uF	63V
C108	UB245100	C. CE. M. CHP	0.1uF	25V
C109	Vi845900	C. EL	10uF	63V
C110	UB245100	C. CE. M. CHP	0.1uF	25V
C111	UB245100	C. CE. M. CHP	0.1uF	25V
C112	Vi845600	C. EL	47uF	50V
C113	Vi845900	C. EL	10uF	63V
C114	UB245100	C. CE. M. CHP	0.1uF	25V
C115	UB245100	C. CE. M. CHP	0.1uF	25V
C116	UB044100	C. CE. M. CHP	0.01uF	50V
C117	UB245100	C. CE. M. CHP	0.1uF	25V
C118	Vi845600	C. EL	47uF	50V
C119	Vi845900	C. EL	10uF	63V
C120	UB245100	C. CE. M. CHP	0.1uF	25V
C121	UB245100	C. CE. M. CHP	0.1uF	25V
C122	UB044100	C. CE. M. CHP	0.01uF	50V
C123	UB245100	C. CE. M. CHP	0.1uF	25V
C124	Vi841800	C. EL	100uF	10V
C125	VJ900900	C. CE. M. CHP	39pF	50V
C126	VJ900700	C. CE. M. CHP	33pF	50V
C127	UT653680	C. PP	6800pF	100V
C128	UB245100	C. CE. M. CHP	0.1uF	25V
C129	UT653680	C. PP	6800pF	100V
C130	Vi841800	C. EL	100uF	10V
C131	Vi841800	C. EL	100uF	10V
C132	Vi845900	C. EL	10uF	63V
C133	UB245100	C. CE. M. CHP	0.1uF	25V
C134	Vi845900	C. EL	10uF	63V
C135	UB245100	C. CE. M. CHP	0.1uF	25V
C136	UB245100	C. CE. M. CHP	0.1uF	25V
C137	Vi845600	C. EL	47uF	50V
C138	Vi845900	C. EL	10uF	63V
C139	UB245100	C. CE. M. CHP	0.1uF	25V
C140	UB245100	C. CE. M. CHP	0.1uF	25V
C141	UB044100	C. CE. M. CHP	0.01uF	50V
C142	UB245100	C. CE. M. CHP	0.1uF	25V
C143	Vi845600	C. EL	47uF	50V
C144	Vi845900	C. EL	10uF	63V
C145	UB245100	C. CE. M. CHP	0.1uF	25V
C146	UB245100	C. CE. M. CHP	0.1uF	25V
C147	UB044100	C. CE. M. CHP	0.01uF	50V

* New Parts

Schm Ref.	PART NO.	Description		
C148	UB245100	C. CE. M. CHP	0.1uF	25V
C149	UB245100	C. CE. M. CHP	0.1uF	25V
C150	UB245100	C. CE. M. CHP	0.1uF	25V
C151	UB245100	C. CE. M. CHP	0.1uF	25V
C152	Vi845900	C. EL	10uF	63V
C153	Vi845900	C. EL	10uF	63V
C154	Vi845900	C. EL	10uF	63V
C155	Vi845900	C. EL	10uF	63V
C156	Vi842600	C. EL	100uF	16V
C157	UB245100	C. CE. M. CHP	0.1uF	25V
C158	UB245100	C. CE. M. CHP	0.1uF	25V
C159	Vi841900	C. EL	220uF	10V
C160	Vi842600	C. EL	100uF	16V
C161	UB245100	C. CE. M. CHP	0.1uF	25V
C162	UB245100	C. CE. M. CHP	0.1uF	25V
C163	Vi841900	C. EL	220uF	10V
C164	Vi841400	C. EL	1000uF	6.3V
C165	Vi845900	C. EL	10uF	63V
C166	Vi845900	C. EL	10uF	63V
C167	Vi845900	C. EL	10uF	63V
C168	Vi845900	C. EL	10uF	63V
C188	Vi845600	C. EL	47uF	50V
C189	Vi845600	C. EL	47uF	50V
C190	Vi845900	C. EL	10uF	63V
C193	Vi845900	C. EL	10uF	63V
C194	Vi845900	C. EL	10uF	63V
C197	Vi845900	C. EL	10uF	63V
C198	Vi845900	C. EL	10uF	63V
C201	Vi845900	C. EL	10uF	63V
C202	Vi845900	C. EL	10uF	63V
C205	Vi845900	C. EL	10uF	63V
C207	Vi842800	C. EL	330uF	16V
C208	Vi842800	C. EL	330uF	16V
C210	UB245100	C. CE. M. CHP	0.1uF	25V
C211	UB245100	C. CE. M. CHP	0.1uF	25V
C212	Vi846000	C. EL	22uF	63V
C213	FU451100	C. MICA	10pF	500V
C214	Vi842900	C. EL	470uF	16V
C215	Vi842900	C. EL	470uF	16V
C216	UB245100	C. CE. M. CHP	0.1uF	25V
C217	UB245100	C. CE. M. CHP	0.1uF	25V
C218	FU451100	C. MICA	10pF	500V
C219	Vi846000	C. EL	22uF	63V
C220	Vi846000	C. EL	22uF	63V
C221	FU451100	C. MICA	10pF	500V
C224	FU451100	C. MICA	10pF	500V
C225	Vi846000	C. EL	22uF	63V
C226	Vi846000	C. EL	22uF	63V
C227	FU451100	C. MICA	10pF	500V
C230	FU451100	C. MICA	10pF	500V
C231	Vi846000	C. EL	22uF	63V
C232	Vi846000	C. EL	22uF	63V
C233	FU451100	C. MICA	10pF	500V

* New Parts

DSP-A3090

P.C.B. DSP

DSP-A3090

Schm Ref.	PART NO.	Description		
C236	FU451100	C. MICA	10pF	500V
C237	Vi846000	C. EL	22uF	63V
C238	UB051470	C. CE. M. CHP	47pF	50V
C239	UB051470	C. CE. M. CHP	47pF	50V
C240	UB051470	C. CE. M. CHP	47pF	50V
C241	UB051470	C. CE. M. CHP	47pF	50V
C242	UB051470	C. CE. M. CHP	47pF	50V
C243	UB051470	C. CE. M. CHP	47pF	50V
C244	UB245100	C. CE. M. CHP	0. 1uF	25V
C245	UB245100	C. CE. M. CHP	0. 1uF	25V
C246	UB245100	C. CE. M. CHP	0. 1uF	25V
C247	UB052100	C. CE. M. CHP	100pF	50V
C248	UB052100	C. CE. M. CHP	100pF	50V
C250	UB052100	C. CE. M. CHP	100pF	50V
C251	UB052100	C. CE. M. CHP	100pF	50V
C252	UB052100	C. CE. M. CHP	100pF	50V
C253	UB052100	C. CE. M. CHP	100pF	50V
C254	UB052100	C. CE. M. CHP	100pF	50V
C255	UB052100	C. CE. M. CHP	100pF	50V
C256	UB052100	C. CE. M. CHP	100pF	50V
C257	UB052100	C. CE. M. CHP	100pF	50V
C259	UB245100	C. CE. M. CHP	0. 1uF	25V
C260	UB245100	C. CE. M. CHP	0. 1uF	25V
C261	UB245100	C. CE. M. CHP	0. 1uF	25V
C262	Vi842800	C. EL	330uF	16V
C263	UB245100	C. CE. M. CHP	0. 1uF	25V
C264	UB245100	C. CE. M. CHP	0. 1uF	25V
C270	VJ899700	C. CE. M. CHP	12pF	50V
C271	UB245100	C. CE. M. CHP	0. 1uF	25V
C272	VG277500	C. CE. TUBLR	56pF	50V
C273	VG276600	C. CE. TUBLR	22pF	50V
C401	VD930900	C. CE. SMI	0. 1uF	25V
C402	VH053100	C. CE. TUBLR	0. 1uF	50V
C403	VH053100	C. CE. TUBLR	0. 1uF	50V
C404	Vi844900	C. EL	1uF	50V
C405	UT452100	C. PP	100pF	100V (UCR)
C406	UT452220	C. PP	220pF	100V (UCR)
C406	UT452390	C. PP	390pF	100V (ABG)
C407	UT452100	C. PP	100pF	100V (UCR)
C408	UT452220	C. PP	220pF	100V (UCR)
C408	UT452390	C. PP	390pF	100V (ABG)
C409	Vi844900	C. EL	1uF	50V
C410	UT452470	C. PP	470pF	100V
C411	UT452470	C. PP	470pF	100V
C412	UT452470	C. PP	470pF	100V
C413	UT452470	C. PP	470pF	100V
C414	UT452470	C. PP	470pF	100V
C415	UT452470	C. PP	470pF	100V
C416	UT452470	C. PP	470pF	100V
C417	UT452470	C. PP	470pF	100V
C418	UT452470	C. PP	470pF	100V
C419	UT452470	C. PP	470pF	100V
C420	UT452470	C. PP	470pF	100V

* New Parts

Schm Ref.	PART NO.	Description		
C421	UT452470	C. PP	470pF	100V
C424	Vi845900	C. EL	10uF	63V
C425	UA654390	C. MYLAR	0. 039uF	50V
C426	UA654110	C. MYLAR	0. 011uF	50V
C427	Vi841100	C. EL	220uF	6. 3V
C428	Vi841100	C. EL	220uF	6. 3V
C429	UA654390	C. MYLAR	0. 039uF	50V
C430	UA654110	C. MYLAR	0. 011uF	50V
C431	Vi845900	C. EL	10uF	63V
C432	Vi842600	C. EL	100uF	16V
C433	UA653100	C. MYLAR	1000pF	50V
C434	UA653100	C. MYLAR	1000pF	50V
C435	Vi842600	C. EL	100uF	16V
C436	Vi845900	C. EL	10uF	63V
C437	Vi845900	C. EL	10uF	63V
C438	Vi845900	C. EL	10uF	63V
C439	Vi845200	C. EL	4. 7uF	50V
C440	UT452100	C. PP	100pF	100V (UCR)
C440	UT452220	C. PP	220pF	100V (ABG)
C441	Vi845200	C. EL	4. 7uF	50V
C442	Vi845200	C. EL	4. 7uF	50V
C443	UT452100	C. PP	100pF	100V (UCR)
C443	UT452220	C. PP	220pF	100V (ABG)
C444	Vi845200	C. EL	4. 7uF	50V
C445	Vi845900	C. EL	10uF	63V
C446	UB245100	C. CE. M. CHP	0. 1uF	25V
C447	UB245100	C. CE. M. CHP	0. 1uF	25V
C901	VR168300	C. MYLAR. ML	ECQ-V1H104JL3	
C902	UB245100	C. CE. M. CHP	0. 1uF	25V
C904	UB245100	C. CE. M. CHP	0. 1uF	25V
C905	VJ900700	C. CE. M. CHP	33pF	50V
C906	UB245100	C. CE. M. CHP	0. 1uF	25V
C907	UB245100	C. CE. M. CHP	0. 1uF	25V
C909	VJ836300	C. EL	330uF	6. 3V
C910	VJ836900	C. EL	10uF	16V
C911	VH053100	C. CE. TUBLR	0. 1uF	50V
C912	VH053100	C. CE. TUBLR	0. 1uF	50V
D1	VT332900	DIODE	1SS355	
D2	VT332900	DIODE	1SS355	
D3	VT332900	DIODE	1SS355	
D4	VT332900	DIODE	1SS355	
D5	VT332900	DIODE	1SS355	
D6	VT332900	DIODE	1SS355	
D7	VT332900	DIODE	1SS355	
D8	VT707700	C. TRIM	KV1851-TL	
D9	VT332900	DIODE	1SS355	
D10	VT332900	DIODE	1SS355	
D11	VT332900	DIODE	1SS355	
D12	VT332900	DIODE	1SS355	
D13	VT332900	DIODE	1SS355	
D14	VT332900	DIODE	1SS355	
D15	VT332900	DIODE	1SS355	
D16	VT332900	DIODE	1SS355	

* New Parts

P.C.B. DSP

Schm Ref.	PART NO.	Description	
D17	VT332900	DIODE	1SS355
D18	VT332900	DIODE	1SS355
D19	VT332900	DIODE	1SS355
D20	VT332900	DIODE	1SS355
D21	VT332900	DIODE	1SS355
D22	VT332900	DIODE	1SS355
* D23	VU391800	DIODE. SHOT	AK04 WK
D401	iF004600	DIODE	1SS133 (ABG)
D402	iF004600	DIODE	1SS133 (ABG)
D902	VS132300	LED (re)	SLR-325VCT31 (ABG)
D903	VP593800	LED (or)	SLR-305DCA47
IC1	Xi110D00	IC	MC14577CP
IC2	XR323A00	IC	LT1016IN8
IC3	XF291A00	IC	uPC4570G2
IC4	XR318A00	IC	NJM2904G-T1 OP AMP
IC5	XR318A00	IC	NJM2904G-T1 OP AMP
IC6	XE520A00	IC	uPD74HC00G-T1
* IC7	XRO41A00	IC	TC74HC151AF
* IC8	XRO42A00	IC	TC74HC153AF
IC9	XD660A00	IC	TC74HCU04AF-TP1
IC10	XD660A00	IC	TC74HCU04AF-TP1
IC11	XRO43A00	IC	PD4606A
IC12	XQ935A00	IC	TC55329AJ-35 SRAM
IC13	XR969A00	IC	ZR38500 A3
* IC14	XR449A00	IC	TC55328BJ-15 SRAM
* IC15	XR449A00	IC	TC55328BJ-15 SRAM
* IC16	XR449A00	IC	TC55328BJ-15 SRAM
IC17	XR217C00	IC	SUM CPU
IC18	XM099A00	IC	YSS214-F CDSP
IC19	XQ220A00	IC	KM658128ALG-8 PS-R
IC20	XQ220A00	IC	KM658128ALG-8 PS-R
IC21	XG948E00	IC	YM3436DK
IC22	XE819A00	IC	uPD74HC04G-T1
IC23	XE520A00	IC	uPD74HC00G-T1
* IC24	XR380A00	IC	AK5390-VS-E1
* IC25	XR361A00	IC	AK4320-VM-E1
* IC26	XR361A00	IC	AK4320-VM-E1
* IC27	XR361A00	IC	AK4320-VM-E1
* IC28	XR361A00	IC	AK4320-VM-E1
IC29	XA507A00	IC	AN78N05
IC30	XG780A00	IC	AN79N05
IC31	XE518A00	IC	uPC4574G2
IC37	XF291A00	IC	uPC4570G2
IC38	XF291A00	IC	uPC4570G2
IC39	XF291A00	IC	uPC4570G2
IC40	XF291A00	IC	uPC4570G2
IC41	XK299A00	IC	YSS213-K
* IC42	XRO42A00	IC	TC74HC153AF
IC401	XM356A00	IC	NJM2068LD
IC402	XM356A00	IC	NJM2068LD
IC403	XP580A00	IC	TC9273N-004
* IC404	XRO27A00	IC	TC9162AN
IC405	XP580A00	IC	TC9273N-004

* New Parts

Schm Ref.	PART NO.	Description	
* IC901	XR188A00	IC	LC75710NE FLD
* IC902	XR188A00	IC	LC75710NE FLD
L1	GE901970	COIL	68uH
L2	GE901970	COIL	68uH
L3	GE901970	COIL	68uH
L4	GE901970	COIL	68uH
L5	GE901970	COIL	68uH
L6	GE901970	COIL	68uH
L7	VT623200	FLTR. LC	SBP-4930
L401	VB056900	COIL	220uH (ABG)
L402	VB056900	COIL	220uH (ABG)
* PJ1	VU144400	JACK. PIN	2P
PJ401	VK421600	JACK. PIN	4P
* PJ402	VM750600	JACK. PIN	6P
PJ403	VJ696300	JACK. PIN	4P
Q1	iC241200	TR. CHP	2SC2412K Q, R, S
Q2	VC124000	TR. DGT	DTA144EK
Q3	VC124000	TR. DGT	DTA144EK
Q4	VC124000	TR. DGT	DTA144EK
Q5	VC124000	TR. DGT	DTA144EK
Q6	VD303700	TR	2SC3326 A, B TE85R
Q7	VD303700	TR	2SC3326 A, B TE85R
Q8	VD303700	TR	2SC3326 A, B TE85R
Q9	VD303700	TR	2SC3326 A, B TE85R
Q10	VD303700	TR	2SC3326 A, B TE85R
Q11	VD303700	TR	2SC3326 A, B TE85R
Q12	VD303700	TR	2SC3326 A, B TE85R
Q13	VD303700	TR	2SC3326 A, B TE85R
Q901	iC241200	TR. CHP	2SC2412K Q, R, S
Q902	iC241200	TR. CHP	2SC2412K Q, R, S
Q903	iC241200	TR. CHP	2SC2412K Q, R, S
Q904	iC241200	TR. CHP	2SC2412K Q, R, S
Q905	iC241200	TR. CHP	2SC2412K Q, R, S
Q908	iC241200	TR. CHP	2SC2412K Q, R, S
Q909	iC241200	TR. CHP	2SC2412K Q, R, S
Q910	VD678700	TR. DGT	DTC114ES (ABG)
SW901	VG392900	SW. TACT	SKHVAA
SW902	VG392900	SW. TACT	SKHVAA
SW903	VG392900	SW. TACT	SKHVAA
SW904	VG392900	SW. TACT	SKHVAA
SW905	VG392900	SW. TACT	SKHVAA
SW906	VG392900	SW. TACT	SKHVAA
SW907	VG392900	SW. TACT	SKHVAA
SW908	VG392900	SW. TACT	SKHVAA
SW909	KA804550	SW. PUSH	(UCR)
SW909	VQ121000	SW. PUSH	SPUL (ABG)
U901	VR023400	L. DETCT	SPS-424-1
* V901	VT876400	FL. DSPLY	32-BT-02G
XL1	VT707400	RSNR. CRY5	33MHz
XL2	VT707500	RSNR. CRY5	46.08MHz
XL3	VT928600	RSNR. CRY5	18.432MHz
XL4	Vi951800	RSNR. CE	20MHz
XL5	Vi552000	RSNR. CRY5	12.288MHz

* New Parts

DSP-A3090

P.C.B. DSP & VIDEO

DSP-A3090

Schm Ref.	PART NO.	Description	
*	VJ828000	PIN	IMSA-6024-03E
	VU018900	SUPRT	/FL
	VR011400	SHEET. FL	
	Vi435400	GND. MIL	
	VP750600	SCR. TERM	MEP1700
*	VU178700	P. C. B.	VIDEO(UC)
*	VU178800	P. C. B.	VIDEO(R)
*	VU178900	P. C. B.	VIDEO(A)
*	VU179000	P. C. B.	VIDEO(B)
*	VU194300	P. C. B.	VIDEO(G)
CB1	VB858200	CN. BS. PIN	3P
CB2	VF982200	CN. BS. PIN	14P
CB3	VB858100	CN. BS. PIN	2P
CB101	VG879900	CN. BS. PIN	2P
CB101	VG879900	CN. BS. PIN	2P (RG)
CB103	LA002140	TERM. WRAP	2P
CB104	VS996100	CLIP. FUSE	EYF64BC (UCR)
CB105	VP206500	HOLDER. FUS	EYF-52BC (ABG)
CB106	VP206500	HOLDER. FUS	EYF-52BC (ABG)
CB106	VS996100	CLIP. FUSE	EYF64BC (UCR)
CB107	VP206500	HOLDER. FUS	EYF-52BC (RG)
CB108	VP206500	HOLDER. FUS	EYF-52BC (RG)
CB109	LA002140	TERM. WRAP	2P (RABG)
CB201	LA002410	TERM. WRAP	2P
CB202	LA002420	TERM. WRAP	3P
CB203	VB858400	CN. BS. PIN	5P
CB301	VL845300	CN. BS. PIN	9P
CB401	VB858100	CN. BS. PIN	2P
CB402	VF982200	CN. BS. PIN	14P
CB503	VQ963100	CN. BS. PIN	10P
CB506	VQ963100	CN. BS. PIN	10P
CB507	LB919030	CN. BS. PIN	3P
C1	Vi845900	C. EL	10uF 63V
C2	Vi841400	C. EL	1000uF 6.3V
C3	UB052100	C. CE. M. CHP	100pF 50V
C4	UB052100	C. CE. M. CHP	100pF 50V
C5	Vi845900	C. EL	10uF 63V
C6	Vi841400	C. EL	1000uF 6.3V
C7	UB052100	C. CE. M. CHP	100pF 50V
C8	UB052100	C. CE. M. CHP	100pF 50V
C9	UB052100	C. CE. M. CHP	100pF 50V
C10	UB052100	C. CE. M. CHP	100pF 50V
C11	VF466900	C. CE. TUBLR	470pF 50V
C12	UB052100	C. CE. M. CHP	100pF 50V
C13	UB052100	C. CE. M. CHP	100pF 50V
C14	VG279600	C. CE. TUBLR	3300pF 16V
C15	Vi845900	C. EL	10uF 63V
C16	Vi841400	C. EL	1000uF 6.3V
C17	Vi845900	C. EL	10uF 63V
C18	Vi841400	C. EL	1000uF 6.3V

* New Parts

Schm Ref.	PART NO.	Description		
C19	Vi845900	C. EL	10uF	63V
C20	Vi845900	C. EL	10uF	63V
C21	Vi845900	C. EL	10uF	63V
C22	Vi845900	C. EL	10uF	63V
C23	Vi845900	C. EL	10uF	63V
C24	Vi845600	C. EL	47uF	50V
C25	Vi845600	C. EL	47uF	50V
C26	Vi845600	C. EL	47uF	50V
C27	Vi845600	C. EL	47uF	50V
C28	VG279000	C. CE. TUBLR	820pF	50V
C29	VH053100	C. CE. TUBLR	0.1uF	50V
C30	VH053100	C. CE. TUBLR	0.1uF	50V
C31	VG277000	C. CE. TUBLR	33pF	50V
C32	VG277000	C. CE. TUBLR	33pF	50V
C33	Vi845600	C. EL	47uF	50V
C34	Vi845600	C. EL	47uF	50V
C35	VF467300	C. CE. TUBLR	0.01uF	16V
C36	Vi845900	C. EL	10uF	63V
C37	VG276600	C. CE. TUBLR	22pF	50V
C38	VG276600	C. CE. TUBLR	22pF	50V
C39	Vi845200	C. EL	4.7uF	50V
C40	VG278400	C. CE. TUBLR	220pF	50V
C41	VG278100	C. CE. TUBLR	120pF	50V
C42	Vi845600	C. EL	47uF	50V
C43	VG279000	C. CE. TUBLR	820pF	50V
C44	Vi845200	C. EL	4.7uF	50V
C45	Vi845900	C. EL	10uF	63V
C46	VG277000	C. CE. TUBLR	33pF	50V
C47	VF466900	C. CE. TUBLR	470pF	50V
C101	VP795900	C. EL	680uF	25V
C102	Ui377470	C. EL	47uF	63V (R)
C103	UA654100	C. MYLAR	0.01uF	50V
C104	VU466300	C. CE. SAFTY	0.01uF	400V
C108	VJ836900	C. EL	10uF	16V (R)
C201	VR168300	C. MYLAR. ML	ECQ-VIH104JL3	
C202	VR168300	C. MYLAR. ML	ECQ-VIH104JL3	
C203	VR168300	C. MYLAR. ML	ECQ-VIH104JL3	
C204	Vi862200	C. POLY	0.1uF	100V
C205	Vi862200	C. POLY	0.1uF	100V
C206	VK181300	C. EL	4700uF	25V
C207	Vi844900	C. EL	1uF	50V
C208	VK181300	C. EL	4700uF	25V
C209	Vi844900	C. EL	1uF	50V
C210	VK180800	C. EL	6800uF	16V
C211	VK180800	C. EL	6800uF	16V
C212	VK180800	C. EL	6800uF	16V
C213	VK180800	C. EL	6800uF	16V
C214	VK180700	C. EL	4700uF	16V
C215	VK180400	C. EL	1000uF	16V
C216	VK180400	C. EL	1000uF	16V
C217	Vi844900	C. EL	1uF	50V
C218	Vi845600	C. EL	47uF	50V
C219	Vi844900	C. EL	1uF	50V

* New Parts

P.C.B. VIDEO

Schm Ref.	PART NO.	Description		
C220	Vi845600	C. EL	47uF	50V
C221	Vi845600	C. EL	47uF	50V
C222	Vi845600	C. EL	47uF	50V
C223	Vi845600	C. EL	47uF	50V
C224	VR168300	C. MYLAR. ML	ECQ-VIH104JL3	
C301	Vi845900	C. EL	10uF	63V
C302	FG211470	C. CE	47pF	50V
C303	UT452100	C. PP	100pF	100V
C304	VH620800	C. EL	47uF	25V
C305	Vi845900	C. EL	10uF	63V
C306	UT452100	C. PP	100pF	100V
C307	FG211470	C. CE	47pF	50V
C308	VH620800	C. EL	47uF	25V
C309	FU451180	C. MICA	18pF	500V
C310	UA654330	C. MYLAR	0.033uF	50V
C311	FU451180	C. MICA	18pF	500V
C312	UA654330	C. MYLAR	0.033uF	50V
C313	Vi845400	C. EL	22uF	50V
C314	Vi845400	C. EL	22uF	50V
C401	UB052100	C. CE. M. CHP	100pF	50V
C402	Vi841400	C. EL	1000uF	6.3V
C403	Vi841400	C. EL	1000uF	6.3V
C404	UB052100	C. CE. M. CHP	100pF	50V
C405	Vi841400	C. EL	1000uF	6.3V
C406	UB052100	C. CE. M. CHP	100pF	50V
C407	Vi841400	C. EL	1000uF	6.3V
C408	UB052100	C. CE. M. CHP	100pF	50V
C409	Vi845900	C. EL	10uF	63V
C410	Vi845900	C. EL	10uF	63V
C411	Vi845600	C. EL	47uF	50V
C412	Vi845600	C. EL	47uF	50V
C501	UT452470	C. PP	470pF	100V
C502	UT452470	C. PP	470pF	100V
C503	UT452470	C. PP	470pF	100V
C504	UT452470	C. PP	470pF	100V
C505	UT452470	C. PP	470pF	100V
C506	UT452470	C. PP	470pF	100V
C507	UT452470	C. PP	470pF	100V
C508	UT452470	C. PP	470pF	100V
C509	UT452470	C. PP	470pF	100V
C510	UT452470	C. PP	470pF	100V
C511	UT452470	C. PP	470pF	100V
C512	UT452470	C. PP	470pF	100V
C513	UT452470	C. PP	470pF	100V
C514	UT452470	C. PP	470pF	100V
C515	UT452470	C. PP	470pF	100V
C516	UT452470	C. PP	470pF	100V
D1	iF004600	DIODE	1SS133	
D2	iF004600	DIODE	1SS133	
D3	iF004600	DIODE	1SS133	
D4	iF004600	DIODE	1SS133	
D5	iF004600	DIODE	1SS133	
D6	VG435100	DIODE. ZENR	MTZJ2.0B	2.0V

*New Parts

Schm Ref.	PART NO.	Description		
D7	iF004600	DIODE	1SS133	
D8	iF004600	DIODE	1SS133	
D9	iF004600	DIODE	1SS133	
D10	iF004600	DIODE	1SS133	
D11	iF004600	DIODE	1SS133	
D101	VR253700	DIODE. BRG	S1NB20	1.0A 200V
D102	iF004600	DIODE	1SS133	
D103	VG440400	DIODE. ZENR	MTZJ13A	13V(R)
D201	VR253700	DIODE. BRG	S1NB20	1.0A 200V
D202	VM705800	DIODE. BRG	RBA-406B	4.0A 60V
D203	iF004600	DIODE	1SS133	
* D204	VU391800	DIODE. SHOT	AK04 WK	
* D205	VU391800	DIODE. SHOT	AK04 WK	
D206	iF004600	DIODE	1SS133	
△ F101	KB000780	FUSE	T5.0A	250V(R)
△ F101	KB002980	FUSE	T2.5A	250V(G)
△ F102	KB000780	FUSE	T5.0A	250V(ABG)
△* F102	VU238300	FUSE	12A	250V(UCR)
G101	VR463400	TERM. GND	D3.5	TP00385
G201	VR463400	TERM. GND	D3.5	TP00385
G202	VR463400	TERM. GND	D3.5	TP00385
IC1	Xi109D00	IC	MC14576CP	
IC2	Xi109D00	IC	MC14576CP	
IC3	Xi109D00	IC	MC14576CP	
IC4	iG105800	IC	uPD4051BC	
IC5	iG105800	IC	uPD4051BC	
IC6	iG105800	IC	uPD4051BC	
IC7	iG105800	IC	uPD4051BC	
IC8	XK313A00	IC	LC7824	
IC9	iG105900	IC	uPD4053BC	
IC10	iG105900	IC	uPD4053BC	
IC11	iG105900	IC	uPD4053BC	
IC12	XL314A00	IC	M35010-062SP	
IC13	iG142200	IC	TC74HCU04AP	
IC14	iG142200	IC	TC74HCU04AP	
IC201	XJ603A00	IC	NJM78M15FA	
IC202	XG505A00	IC	NJM79M15FA	
IC203	Xi124A00	IC	PQ05RF1 5V1A	
IC204	XE436A00	IC	NJM79M05FA	
IC205	Xi124A00	IC	PQ05RF1 5V1A	
IC206	Xi124A00	IC	PQ05RF1 5V1A	
IC207	XE436A00	IC	NJM79M05FA	
IC301	iG067100	IC	uPC1225H	
IC302	iG067100	IC	uPC1225H	
IC401	Xi109D00	IC	MC14576CP	
IC402	iG105800	IC	uPD4051BC	
IC403	iG105800	IC	uPD4051BC	
IC404	iG105900	IC	uPD4053BC	
* JK1	VU245200	CN. DIN	1P	
JK2	VP113600	CN. DIN	2P	
JK3	VP113600	CN. DIN	2P	
JK4	VP113600	CN. DIN	2P	
* JK5	VT973000	CN. DIN	2P(RG)	

*New Parts

DSP-A3090

P.C.B. VIDEO & MAIN

DSP-A3090

Schm Ref.	PART NO.	Description	
* JK5	VT973000	CN. DIN	2P
L1	VM703900	COIL	15uH
PJ401	VR110100	JACK. PIN	2P
PJ402	VR110100	JACK. PIN	2P
PJ403	VR110100	JACK. PIN	2P
PJ404	VR110100	JACK. PIN	2P
* PJ405	VN134600	JACK. PIN	1P
PJ501	VM725900	JACK. PIN	4P
PJ502	VM726000	JACK. PIN	6P
PJ503	VM726000	JACK. PIN	6P
Q1	iC260320	TR	2SC2603 E, F
Q2	iC287820	TR	2SC2878 A, B
Q3	iC260320	TR	2SC2603 E, F
Q4	VH964100	TR. DGT	DTA143ES
Q5	iC260320	TR	2SC2603 E, F
Q6	iC260320	TR	2SC2603 E, F
Q7	iC260320	TR	2SC2603 E, F
Q8	iC260320	TR	2SC2603 E, F
Q9	iC260320	TR	2SC2603 E, F
Q10	iC260320	TR	2SC2603 E, F
Q11	VD678700	TR. DGT	DTC114ES
Q12	iA101521	TR	2SA1015 Y
Q13	iC224030	TR	2SC2240 GR, BL
Q14	iC224030	TR	2SC2240 GR, BL
Q15	iC053540	TR	2SC535 A, B, C
Q101	VD488500	TR. DGT	DTC143XS
Q102	VR510800	TR	2SD2396 J, K(R)
* Q301A	iX636400	TR	2SA1940 R, O
* Q301C	iX636410		2SC5197 R, O
Q302	iC224000	TR	2SC2240 GR, BL
* Q304A	iX636400	TR	2SA1940 R, O
* Q304C	iX636410		2SC5197 R, O
Q305	iC224000	TR	2SC2240 GR, BL
Q307	iC224030	TR	2SC2240 GR, BL
Q308	iC224030	TR	2SC2240 GR, BL
Q401	iC260320	TR	2SC2603 E, F
Q402	iC260320	TR	2SC2603 E, F
R103	VK187800	R. FUS	100Ω 1/4W(R)
R310	VK189400	R. FUS	2.7KΩ 1/4W
R311	VK189100	R. FUS	1.2KΩ 1/4W
R315	VK189400	R. FUS	2.7KΩ 1/4W
R316	VK189100	R. FUS	1.2KΩ 1/4W
RY101	VK539200	RELAY	DC DH12D1-OM
△ T101	XC115A00	TRANS. PWR	(R)
△ T101	XC116A00	TRANS. PWR	(UC)
△ T101	XC117A00	TRANS. PWR	(B)
△ T101	XK354A00	TRANS	(BG)
△* TE101	VU186900	OUTLET. AC	3P(UCR)
△* TE101	VU186900	OUTLET. AC	3P(R)
VR301	VJ693000	VR. TRIM	B1KΩ
VR302	VJ693000	VR. TRIM	B1KΩ
XL1	VD980900	RSNR. CRYST	14.3181MHz (UCR)
XL1	VD980900	RSNR. CRYST	14.3181MHz (R)

* New Parts

Schm Ref.	PART NO.	Description	
XL1	VF066800	RSNR. CRYST	17.7344MHz (ABG)
	VJ828000	PIN	IMSA-6024-03E
	BB071360	SCR. TERM	8.3x13
	VL852700	RADIATOR	
	EP600130	SCR. BND. HD	3x6 ZMC2-Y
*	VU178000	P. C. B.	MAIN(UC)
*	VU178100	P. C. B.	MAIN(R)
*	VU178200	P. C. B.	MAIN(ABG)
CB301	LA002570	TERM. WRAP	3P
CB302	LA002000	TERM. WRAP	2P
CB303	LA002000	TERM. WRAP	2P
CB304	VD004800	CN. BS. PIN	5P
CB305	VN924000	CN	19P
* CB306	VQ961600	CN	13P
* CB307	VQ963400	CN. BS. PIN	13P
* CB308	VQ963400	CN. BS. PIN	13P
* CB312	VQ961600	CN	13P
CB501	VP206500	HOLDER. FUS	EYF-52BC
CB502	VP206500	HOLDER. FUS	EYF-52BC
CB503	VP206500	HOLDER. FUS	EYF-52BC
CB504	VP206500	HOLDER. FUS	EYF-52BC
C301	Vi846000	C. EL	22uF 63V
C302	Vi846000	C. EL	22uF 63V
C303	Vi845900	C. EL	10uF 63V
C304	Vi846200	C. EL	47uF 63V
C305	UT452100	C. PP	100pF 100V
C306	UT452100	C. PP	100pF 100V
C307	Vi845900	C. EL	10uF 63V
C308	Vi845900	C. EL	10uF 63V
C309	UT452470	C. PP	470pF 100V
C310	UT452470	C. PP	470pF 100V
C311	Vi845900	C. EL	10uF 63V
C312	Vi845900	C. EL	10uF 63V
C313	UT452470	C. PP	470pF 100V
C314	UT452470	C. PP	470pF 100V
C315	Vi845900	C. EL	10uF 63V
C316	UT452470	C. PP	470pF 100V
C317	Vi845900	C. EL	10uF 63V
C318	UT452470	C. PP	470pF 100V
C319	Vi845900	C. EL	10uF 63V
C320	UT452470	C. PP	470pF 100V
C321	Vi845900	C. EL	10uF 63V
C322	VH622100	C. EL	10uF 50V
C324	UT452100	C. PP	100pF 100V
C325	UT452100	C. PP	100pF 100V
C326	UT452100	C. PP	100pF 100V
C327	VH622100	C. EL	10uF 50V
C328	VH622100	C. EL	10uF 50V
C329	UT452100	C. PP	100pF 100V
C330	UT452100	C. PP	100pF 100V

* New Parts

P.C.B. MAIN

Schm Ref.	PART NO.	Description		
C331	VH622100	C. EL	10uF	50V
C332	VH622100	C. EL	10uF	50V
C333	VH574800	C. EL	47uF	100V
C334	VH574800	C. EL	47uF	100V
C335	UT452100	C. PP	100pF	100V
C336	UT452100	C. PP	100pF	100V
C339	Vi841800	C. EL	100uF	10V
C340	Vi841800	C. EL	100uF	10V
C341	FU451150	C. MICA	15pF	500V
C342	FU451150	C. MICA	15pF	500V
C343	VH622200	C. EL	22uF	50V
C344	VH622200	C. EL	22uF	50V
C345	FU452100	C. MICA	100pF	500V
C346	FU452100	C. MICA	100pF	500V
C347	FU452100	C. MICA	100pF	500V
C348	FU452100	C. MICA	100pF	500V
C349	VR325300	C. MYLAR	0.047uF	100V
C350	VR325300	C. MYLAR	0.047uF	100V
C351	Vi846900	C. EL	10uF	100V
C352	Vi846900	C. EL	10uF	100V
C353	Vi846900	C. EL	10uF	100V
C354	Vi846900	C. EL	10uF	100V
C355	UT454100	C. PP	0.01uF	100V
C356	UT454100	C. PP	0.01uF	100V
C357	UT454100	C. PP	0.01uF	100V
C358	UT454100	C. PP	0.01uF	100V
C359	FG214100	C. CE	0.01uF	50V
C360	VH622100	C. EL	10uF	50V
C362	UT452100	C. PP	100pF	100V
C363	VH622100	C. EL	10uF	50V
C364	UT452100	C. PP	100pF	100V
C365	UT452100	C. PP	100pF	100V
C366	VH574800	C. EL	47uF	100V
C368	VH622100	C. EL	10uF	50V
C369	UT452100	C. PP	100pF	100V
C370	UT452100	C. PP	100pF	100V
C371	UT452100	C. PP	100pF	100V
C372	VH622100	C. EL	10uF	50V
C373	UT452100	C. PP	100pF	100V
C374	VH622100	C. EL	10uF	50V
C375	VH574800	C. EL	47uF	100V
C376	UT452100	C. PP	100pF	100V
C378	Vi841800	C. EL	100uF	10V
C379	FU451150	C. MICA	15pF	500V
C380	VH622200	C. EL	22uF	50V
C381	FU452100	C. MICA	100pF	500V
C382	FU452100	C. MICA	100pF	500V
C383	VR325300	C. MYLAR	0.047uF	100V
C384	Vi845100	C. EL	3.3uF	50V
C385	Vi841800	C. EL	100uF	10V
C387	FU451150	C. MICA	15pF	500V
C388	Vi841800	C. EL	100uF	10V
C389	VH622200	C. EL	22uF	50V

* New Parts

Schm Ref.	PART NO.	Description		
C390	FU451150	C. MICA	15pF	500V
C391	Vi841800	C. EL	100uF	10V
C392	VH622200	C. EL	22uF	50V
C393	FU452100	C. MICA	100pF	500V
C394	FU452100	C. MICA	100pF	500V
C395	FU452100	C. MICA	100pF	500V
C396	FU452100	C. MICA	100pF	500V
C397	Vi845000	C. EL	2.2uF	50V
C398	VK179200	C. EL	2200uF	6.3V
C399	UT454100	C. PP	0.01uF	100V
C400	Vi846900	C. EL	10uF	100V
C401	VR325300	C. MYLAR	0.047uF	100V
C404	Vi846900	C. EL	10uF	100V
C405	UT454100	C. PP	0.01uF	100V
C406	VR325300	C. MYLAR	0.047uF	100V
C409	UA654470	C. MYLAR	0.047uF	50V
C410	UA654470	C. MYLAR	0.047uF	50V
C425	Vi845600	C. EL	47uF	50V
C431	Vi862200	C. POLY	0.1uF	100V
C432	Vi862200	C. POLY	0.1uF	100V
* C433	VU238100	C. EL	27000uF	63V
* C434	VU238100	C. EL	27000uF	63V
C435	Vi862200	C. POLY	0.1uF	100V
C436	Vi862200	C. POLY	0.1uF	100V
C437	Vi862200	C. POLY	0.1uF	100V
C438	Vi862200	C. POLY	0.1uF	100V
C439	VG875500	C. EL	4700uF	45V
C440	VG875500	C. EL	4700uF	45V
C462	UT452470	C. PP	470pF	100V
C463	Vi845900	C. EL	10uF	63V
C495	VE324800	C. MYLAR.ML	0.01uF	50V
C496	VE326200	C. MYLAR.ML	0.15uF	50V
C497	VE324800	C. MYLAR.ML	0.01uF	50V
C498	VE326200	C. MYLAR.ML	0.15uF	50V
C499	VE324800	C. MYLAR.ML	0.01uF	50V
C500	VE326200	C. MYLAR.ML	0.15uF	50V
C551	UT454100	C. PP	0.01uF	100V (ABG)
C552	UT454100	C. PP	0.01uF	100V (ABG)
C553	FG244220	C. CE	0.022uF	50V (ABG)
C554	FG244220	C. CE	0.022uF	50V (ABG)
C555	UT454100	C. PP	0.01uF	100V (ABG)
C556	FG244220	C. CE	0.022uF	50V (ABG)
C557	UT454100	C. PP	0.01uF	100V (ABG)
C558	UT454100	C. PP	0.01uF	100V (ABG)
C559	FG244220	C. CE	0.022uF	50V (ABG)
C560	FG244220	C. CE	0.022uF	50V (ABG)
C561	UT454100	C. PP	0.01uF	100V (ABG)
C562	UT454100	C. PP	0.01uF	100V (ABG)
C563	FG244220	C. CE	0.022uF	50V (ABG)
C564	FG244220	C. CE	0.022uF	50V (ABG)
C565	VD339900	C. PP	220pF	100V (ABG)
C566	VD339900	C. PP	220pF	100V (ABG)
C567	VD339900	C. PP	220pF	100V (ABG)

* New Parts

DSP-A3090

P.C.B. MAIN

DSP-A3090

Schm Ref.	PART NO.	Description		
C568	VD339900	C. PP	220pF	100V (ABG)
C569	VD339900	C. PP	220pF	100V (ABG)
C571	UA652470	C. MYLAR	470pF	50V (ABG)
C572	UA652470	C. MYLAR	470pF	50V (ABG)
C573	UT453100	C. PP	1000pF	100V (UCR)
C573	UT453120	C. PP	1200pF	100V (ABG)
C574	UT453100	C. PP	1000pF	100V (UCR)
C574	UT453120	C. PP	1200pF	100V (ABG)
C575	UT453100	C. PP	1000pF	100V (UCR)
C575	UT453120	C. PP	1200pF	100V (ABG)
C576	UT453100	C. PP	1000pF	100V (UCR)
C576	UT453120	C. PP	1200pF	100V (ABG)
C577	UT453100	C. PP	1000pF	100V (UCR)
C577	UT453120	C. PP	1200pF	100V (ABG)
D301	iF004600	DIODE	1SS133	
D302	iF004600	DIODE	1SS133	
D303	iF004600	DIODE	1SS133	
D304	iF004600	DIODE	1SS133	
D305	iF004600	DIODE	1SS133	
D306	iF004600	DIODE	1SS133	
D307	iF004600	DIODE	1SS133	
D308	iF004600	DIODE	1SS133	
D309	iF004600	DIODE	1SS133	
D310	VG443900	DIODE. ZENR	MTZJ33D	33V
D311	iF004600	DIODE	1SS133	
D312	iF004600	DIODE	1SS133	
D313	VG439300	DIODE. ZENR	MTZJ9. 1C	9. 1V
D314	iF004600	DIODE	1SS133	
D315	iF004600	DIODE	1SS133	
D316	iF004600	DIODE	1SS133	
D317	iF004600	DIODE	1SS133	
D318	iF004600	DIODE	1SS133	
D319	iF004600	DIODE	1SS133	
D320	VG440800	DIODE. ZENR	MTZJ15B	15V
D321	iF004600	DIODE	1SS133	
D322	iF004600	DIODE	1SS133	
D323	iF004600	DIODE	1SS133	
D331	Vi234100	DIODE. BRG	RBV-602	
D332	VN011300	DIODE. BRG	D3SBA20	4A 200V
△ F551	KB000760	FUSE	T3. 15A	250V (RABG)
△ * F551	VU079100	FUSE	4A	125A (UC)
△ F552	KB000760	FUSE	T3. 15A	250V (RABG)
△ * F552	VU079100	FUSE	4A	125A (UC)
G301	VR463400	TERM. GND	D3. 5	TP00385
G302	VR463400	TERM. GND	D3. 5	TP00385
G303	VR463400	TERM. GND	D3. 5	TP00385
L301	VC664100	COIL	0. 95uH	
L302	VC664100	COIL	0. 95uH	
L303	VC664100	COIL	0. 95uH	
L304	VK175800	COIL	1. 5uH	
L305	VK175800	COIL	1. 5uH	
L306	VK175800	COIL	1. 5uH	
L307	VK175800	COIL	1. 5uH	

* New Parts

Schm Ref.	PART NO.	Description		
PJ551	VJ715400	JACK. PIN	4P (RABG)	
PJ552	VN930600	JACK. PIN	4P (RABG)	
PJ554	VN930700	JACK. PIN	4P (RABG)	
PJ555	VJ133600	JACK. PIN	4P (RABG)	
PJ556	VJ133600	JACK. PIN	4P (RABG)	
Q301	VK432900	TR	2SD1915F	S, T
Q302	VK432900	TR	2SD1915F	S, T
Q303	VK432900	TR	2SD1915F	S, T
Q304	VK432900	TR	2SD1915F	S, T
Q305	VK432900	TR	2SD1915F	S, T
Q306	VK432900	TR	2SD1915F	S, T
Q307	VK432900	TR	2SD1915F	S, T
Q308	VK432900	TR	2SD1915F	S, T
Q309	VK432900	TR	2SD1915F	S, T
Q310	VP872600	TR	2SA1708	S, T
Q311	iA097000	TR	2SA970	GR, BL
Q312	iA097000	TR	2SA970	GR, BL
Q313	iA097000	TR	2SA970	GR, BL
Q314	iA097000	TR	2SA970	GR, BL
Q315	iC1815C0	TR	2SC1815	Y
Q316	iC1815C0	TR	2SC1815	Y
Q317	iC1815C0	TR	2SC1815	Y
Q318	iC1815C0	TR	2SC1815	Y
Q319	iC1815C0	TR	2SC1815	Y
Q320	iC1815C0	TR	2SC1815	Y
Q321	VE198800	TR	2SC2705	O, Y
Q322	VE198800	TR	2SC2705	O, Y
Q323	VE198700	TR	2SA1145	O, Y
Q324	VE198700	TR	2SA1145	O, Y
Q325	VC398100	TR	2SC1846	S
Q326	VC398100	TR	2SC1846	S
Q327	VE198700	TR	2SA1145	O, Y
Q328	VE198700	TR	2SA1145	O, Y
Q329	VE198800	TR	2SC2705	O, Y
Q330	VE198800	TR	2SC2705	O, Y
Q331	iA097000	TR	2SA970	GR, BL
Q332	iA097000	TR	2SA970	GR, BL
Q333	iC1815C0	TR	2SC1815	Y
Q334	iC1815C0	TR	2SC1815	Y
Q335	iA097000	TR	2SA970	GR, BL
Q336	iA093320	TR	2SA933S	Q, R
Q337	iA097000	TR	2SA970	GR, BL
Q338	iC1815C0	TR	2SC1815	Y
Q339	iC224030	TR	2SC2240	GR, BL
Q340	iC224030	TR	2SC2240	GR, BL
Q341	iA097000	TR	2SA970	GR, BL
Q342	iA097000	TR	2SA970	GR, BL
Q343	iC1815C0	TR	2SC1815	Y
Q344	iC1815C0	TR	2SC1815	Y
Q345	iC1815C0	TR	2SC1815	Y
Q346	VE198800	TR	2SC2705	O, Y
Q347	VE198700	TR	2SA1145	O, Y
Q348	VC398100	TR	2SC1846	S

* New Parts

P.C.B. MAIN & FUNCTION

Schm Ref.	PART NO.	Description
Q349	VE198700	TR 2SA1145 O, Y
Q350	VE198800	TR 2SC2705 O, Y
Q351	iC1815C0	TR 2SC1815 Y
Q352	VE198700	TR 2SA1145 O, Y
Q353	VE198800	TR 2SC2705 O, Y
Q354	iC1815C0	TR 2SC1815 Y
Q355	iC224030	TR 2SC2240 GR, BL
Q356	iA097000	TR 2SA970 GR, BL
Q357	VE198700	TR 2SA1145 O, Y
Q358	VE198800	TR 2SC2705 O, Y
Q359	iC1815C0	TR 2SC1815 Y
Q360	VE198800	TR 2SC2705 O, Y
Q361	iC174020	TR 2SC1740S R, S
Q362	VD488500	TR. DGT DTC143XS
Q363	VD488500	TR. DGT DTC143XS
Q364A	iX632610	TR 2SA1837 O, Y
Q364C	iX632620	TR 2SC4793 O, Y
Q365	VC398100	TR 2SC1846 S
Q366	VE198700	TR 2SA1145 O, Y
Q367	iA093320	TR 2SA933S Q, R
Q368	VK432900	TR 2SD1915F S, T
Q369A	iX801420	TR 2SA1302 O, R
Q369C	iX801430	TR 2SC3281 O, R
Q370	VE198800	TR 2SC2705 O, Y
Q371A	iX632610	TR 2SA1837 O, Y
Q371C	iX632620	TR 2SC4793 O, Y
Q372	VC398100	TR 2SC1846 S
Q373	VE198700	TR 2SA1145 O, Y
Q374A	iX801420	TR 2SA1302 O, R
Q374C	iX801430	TR 2SC3281 O, R
Q375	iC224030	TR 2SC2240 GR, BL
Q376	iC224030	TR 2SC2240 GR, BL
Q377A	iX632610	TR 2SA1837 O, Y
Q377C	iX632620	TR 2SC4793 O, Y
Q378A	iX801420	TR 2SA1302 O, R
Q378C	iX801430	TR 2SC3281 O, R
Q379A	iX632610	TR 2SA1837 O, Y
Q379C	iX632620	TR 2SC4793 O, Y
Q380A	iX801420	TR 2SA1302 O, R
Q380C	iX801430	TR 2SC3281 O, R
Q381A	iX632610	TR 2SA1837 O, Y
Q381C	iX632620	TR 2SC4793 O, Y
Q382A	iX801420	TR 2SA1302 O, R
Q382C	iX801430	TR 2SC3281 O, R
R363	VK188000	R. FUS 150Ω 1/4W
R364	VK188000	R. FUS 150Ω 1/4W
R379	VK189500	R. FUS 3.3KΩ 1/4W
R380	VK189500	R. FUS 3.3KΩ 1/4W
R381	VK188700	R. FUS 560Ω 1/4W
R382	VK188700	R. FUS 560Ω 1/4W
R385	VK189100	R. FUS 1.2KΩ 1/4W
R386	VK189100	R. FUS 1.2KΩ 1/4W
R387	VK188400	R. FUS 330Ω 1/4W

* New Parts

Schm Ref.	PART NO.	Description
R388	VK188400	R. FUS 330Ω 1/4W
R393	VJ695400	R. WW 0.22Ωx2 3W
R394	VJ695400	R. WW 0.22Ωx2 3W
R405	VE009700	R. FUS 4.7Ω 1/4W
R406	VE009700	R. FUS 4.7Ω 1/4W
R407	VE009700	R. FUS 4.7Ω 1/4W
R408	VE009700	R. FUS 4.7Ω 1/4W
R430	VK188000	R. FUS 150Ω 1/4W
R438	VK189500	R. FUS 3.3KΩ 1/4W
R439	VK188700	R. FUS 560Ω 1/4W
R441	VK189100	R. FUS 1.2KΩ 1/4W
R442	VK188400	R. FUS 330Ω 1/4W
R471	VK188000	R. FUS 150Ω 1/4W
R473	VK189500	R. FUS 3.3KΩ 1/4W
R478	VK188700	R. FUS 560Ω 1/4W
R482	VK188000	R. FUS 150Ω 1/4W
R484	VK189500	R. FUS 3.3KΩ 1/4W
R490	VK188700	R. FUS 560Ω 1/4W
R503	VK189100	R. FUS 1.2KΩ 1/4W
R504	VK188400	R. FUS 330Ω 1/4W
R505	VK189100	R. FUS 1.2KΩ 1/4W
R506	VK188400	R. FUS 330Ω 1/4W
R519	VE009700	R. FUS 4.7Ω 1/4W
R526	VE009700	R. FUS 4.7Ω 1/4W
RY301	KC002020	RELAY DH24D2-OTM
RY302	KC002020	RELAY DH24D2-OTM
RY303	VK438300	RELAY DH24D2-OTM-
RY304	KC002020	RELAY DH24D2-OTM
* SW301	VT903900	SW. SLIDE SSAA22
* SW302	VT903900	SW. SLIDE SSAA22
SW303	VJ769200	SW. SLIDE ESD-2764
* SW551	VT903900	SW. SLIDE SSAA22(R)
TE551	VJ792600	TERM. SP 8P(UCR)
TE551	VK178900	TERM. SP 8P(ABG)
TE552	VJ792600	TERM. SP 8P(UCR)
TE552	VK178900	TERM. SP 8P(ABG)
VR301	VJ692700	VR. TRIM B330Ω
VR302	VJ692700	VR. TRIM B330Ω
VR303	VJ692700	VR. TRIM B330Ω
VR304	VJ692700	VR. TRIM B330Ω
VR305	VJ692700	VR. TRIM B330Ω
	VJ828000	PIN IMSA-6024-03E
	VL890500	HEAT. SINK T220N31-30
	EX602250	SCR. BND. HD 3x12 ZMC2-BL
* VU177700		P. C. B. FUNCTION(UCR)
* VU177800		P. C. B. FUNCTION(ABG)
CB1	VN924000	CN 19P
CB2	VB858500	CN. BS. PIN 6P
CB3	VQ044600	CN. BS. PIN 13P
* CB4	VP360700	CN. BS. PIN 15P

* New Parts

DSP-A3090

P.C.B. FUNCTION

Schm Ref.	PART NO.	Description		
CB5	VN923200	CN	11P	
CB6	VP360300	CN. BS. PIN	11P	
CB7	VN923300	CN	12P	
CB8	VN924000	CN	19P	
CB9	VB858200	CN. BS. PIN	3P(UCR)	
CB10	VB858300	CN. BS. PIN	4P(ABG)	
CB11	VG904000	SOCKET. IC	CLC3064-0101	
CB301	VQ044600	CN. BS. PIN	13P	
CB302	VB858400	CN. BS. PIN	5P	
CB501	VQ961500	CN. BS. PIN	12P	
CB502	VQ961300	CN. BS. PIN	10P	
CB504	VQ961500	CN. BS. PIN	12P	
CB505	VQ961300	CN. BS. PIN	10P	
CB801	VP361100	CN. BS. PIN	19P	
CB802	VQ963900	CN. BS. PIN	18P	
CB803	VQ962100	CN. BS. PIN	18P	
C1	UB245100	C. CE. M. CHP	0. 1uF	25V
C2	UB245100	C. CE. M. CHP	0. 1uF	25V
C3	UB245100	C. CE. M. CHP	0. 1uF	25V
C4	UB245100	C. CE. M. CHP	0. 1uF	25V
C5	UB245100	C. CE. M. CHP	0. 1uF	25V
C7	Vi841800	C. EL	100uF	10V
C8	Vi841800	C. EL	100uF	10V
C9	UB245100	C. CE. M. CHP	0. 1uF	25V
C11	Vi844800	C. EL	0. 47uF	50V
C12	Vi845000	C. EL	2. 2uF	50V
C13	Vi845000	C. EL	2. 2uF	50V
C14	UB245100	C. CE. M. CHP	0. 1uF	25V
C15	UB245100	C. CE. M. CHP	0. 1uF	25V
C16	UB245100	C. CE. M. CHP	0. 1uF	25V
C17	Vi845900	C. EL	10uF	63V
C18	Vi845600	C. EL	47uF	50V
C19	UT452100	C. PP	100pF	100V
C20	UT452100	C. PP	100pF	100V
C21	Vi845600	C. EL	47uF	50V
C22	UB245100	C. CE. M. CHP	0. 1uF	25V
C23	Vi845600	C. EL	47uF	50V
C24	VE632800	C. EL	0. 047F	5. 5V
C25	Vi841400	C. EL	1000uF	6. 3V
C26	UB245100	C. CE. M. CHP	0. 1uF	25V
C27	Vi845000	C. EL	2. 2uF	50V
C28	Vi845900	C. EL	10uF	63V
C29	Vi845900	C. EL	10uF	63V
C30	Vi845900	C. EL	10uF	63V
C31	Vi845900	C. EL	10uF	63V
C32	UB245100	C. CE. M. CHP	0. 1uF	25V
C33	Vi845000	C. EL	2. 2uF	50V
C34	Vi845000	C. EL	2. 2uF	50V
C35	Vi845000	C. EL	2. 2uF	50V
C36	Vi845000	C. EL	2. 2uF	50V
C37	Vi845000	C. EL	2. 2uF	50V
C38	Vi845000	C. EL	2. 2uF	50V
C39	Vi845000	C. EL	2. 2uF	50V

* New Parts

Schm Ref.	PART NO.	Description		
C40	Vi845000	C. EL	2. 2uF	50V
C41	Vi841800	C. EL	100uF	10V
C42	UT452100	C. PP	100pF	100V
C43	UT452100	C. PP	100pF	100V
C44	Vi841800	C. EL	100uF	10V
C45	Vi841800	C. EL	100uF	10V
C46	UT452100	C. PP	100pF	100V
C47	UT452100	C. PP	100pF	100V
C48	Vi841800	C. EL	100uF	10V
C49	Vi841800	C. EL	100uF	10V
C50	UA652100	C. MYLAR	100pF	50V
C51	UA652100	C. MYLAR	100pF	50V
C52	Vi841800	C. EL	100uF	10V
C53	Vi841800	C. EL	100uF	10V
C54	UA652100	C. MYLAR	100pF	50V
C55	UA652100	C. MYLAR	100pF	50V
C56	Vi841800	C. EL	100uF	10V
C57	UT454270	C. PP	0. 027uF	100V
C58	UT454270	C. PP	0. 027uF	100V
C59	UT454270	C. PP	0. 027uF	100V
C60	UT454270	C. PP	0. 027uF	100V
C61	UT454270	C. PP	0. 027uF	100V
C62	UT454270	C. PP	0. 027uF	100V
C63	Vi845900	C. EL	10uF	63V
C64	Vi845900	C. EL	10uF	63V
C65	Vi845900	C. EL	10uF	63V
C66	Vi845900	C. EL	10uF	63V
C67	UT454270	C. PP	0. 027uF	100V
C68	Vi845900	C. EL	10uF	63V
C69	Vi845900	C. EL	10uF	63V
C70	UT454270	C. PP	0. 027uF	100V
C71	Vi844500	C. EL	0. 1uF	50V
C72	Vi845900	C. EL	10uF	63V
C73	Vi845900	C. EL	10uF	63V
C74	Vi844500	C. EL	0. 1uF	50V
C75	Vi844500	C. EL	0. 1uF	50V
C76	Vi845900	C. EL	10uF	63V
C77	Vi845900	C. EL	10uF	63V
C78	Vi844500	C. EL	0. 1uF	50V
C79	Vi844500	C. EL	0. 1uF	50V
C80	Vi845900	C. EL	10uF	63V
C81	Vi845900	C. EL	10uF	63V
C82	Vi844500	C. EL	0. 1uF	50V
C83	Vi845000	C. EL	2. 2uF	50V
C84	Vi845000	C. EL	2. 2uF	50V
C85	Vi845000	C. EL	2. 2uF	50V
C86	Vi845000	C. EL	2. 2uF	50V
C87	Vi845000	C. EL	2. 2uF	50V
C88	Vi845000	C. EL	2. 2uF	50V
C89	Vi845600	C. EL	47uF	50V
C90	Vi845900	C. EL	10uF	63V
C91	UB245100	C. CE. M. CHP	0. 1uF	25V
C92	Vi845600	C. EL	47uF	50V

* New Parts

DSP-A3090

P.C.B. FUNCTION

Schm Ref.	PART NO.	Description		
C93	Vi845600	C. EL	47uF	50V
C94	UA652100	C. MYLAR	100pF	50V
C95	UA652100	C. MYLAR	100pF	50V
C96	UA654390	C. MYLAR	0.039uF	50V
C97	UA654330	C. MYLAR	0.033uF	50V
C98	VR168300	C. MYLAR. ML	ECQ-VIH104JL3	
C99	VR168300	C. MYLAR. ML	ECQ-VIH104JL3	
C100	UA654330	C. MYLAR	0.033uF	50V
C101	UA654390	C. MYLAR	0.039uF	50V
C102	Vi845600	C. EL	47uF	50V
C103	Vi845600	C. EL	47uF	50V
C104	FU451100	C. MICA	10pF	500V
C105	Vi845600	C. EL	47uF	50V
C106	Vi845600	C. EL	47uF	50V
C107	Vi845600	C. EL	47uF	50V
C108	Vi845600	C. EL	47uF	50V
C109	FU451100	C. MICA	10pF	500V
C110	UA653560	C. MYLAR	5600pF	50V
C111	UA653560	C. MYLAR	5600pF	50V
C112	UA652100	C. MYLAR	100pF	50V
C113	UA652100	C. MYLAR	100pF	50V
C114	Vi844900	C. EL	1uF	50V
C115	Vi845600	C. EL	47uF	50V
C116	Vi845600	C. EL	47uF	50V
C117	Vi845900	C. EL	10uF	63V
C118	Vi845900	C. EL	10uF	63V
C119	FU451100	C. MICA	10pF	500V
C120	FU451100	C. MICA	10pF	500V
C130	Vi845600	C. EL	47uF	50V
C131	Vi845600	C. EL	47uF	50V
C132	UA652100	C. MYLAR	100pF	50V
C133	UA652100	C. MYLAR	100pF	50V
C134	UA652100	C. MYLAR	100pF	50V
C135	Vi845600	C. EL	47uF	50V
C136	Vi845600	C. EL	47uF	50V
C137	UB245100	C. CE. M. CHP	0.1uF	25V
C138	Vi841400	C. EL	1000uF	6.3V
C139	Vi841800	C. EL	100uF	10V
C140	Vi841800	C. EL	100uF	10V
C141	Vi845900	C. EL	10uF	63V
C142	Vi845900	C. EL	10uF	63V
C143	Vi845900	C. EL	10uF	63V
C144	Vi845900	C. EL	10uF	63V
C145	UB245100	C. CE. M. CHP	0.1uF	25V
C301	UB245100	C. CE. M. CHP	0.1uF	25V
C302	UB245100	C. CE. M. CHP	0.1uF	25V
C303	UB245100	C. CE. M. CHP	0.1uF	25V
C304	VG722100	C. EL	1uF	50V
C305	UB245100	C. CE. M. CHP	0.1uF	25V
C801	UA654470	C. MYLAR	0.047uF	50V
C802	UA654470	C. MYLAR	0.047uF	50V
C803	Vi844600	C. EL	0.22uF	50V
C804	UA654470	C. MYLAR	0.047uF	50V

* New Parts

Schm Ref.	PART NO.	Description		
C805	UA654470	C. MYLAR	0.047uF	50V
C806	Vi844600	C. EL	0.22uF	50V
C807	Vi845100	C. EL	3.3uF	50V
C808	Vi845900	C. EL	10uF	63V
C809	FU351220	C. MICA	22pF	500V
C810	Vi844600	C. EL	0.22uF	50V
C811	FU351220	C. MICA	22pF	500V
C812	Vi844600	C. EL	0.22uF	50V
C813	Vi845900	C. EL	10uF	63V
C814	Vi845900	C. EL	10uF	63V
C815	FU351220	C. MICA	22pF	500V
C816	Vi844600	C. EL	0.22uF	50V
C817	VR168300	C. MYLAR. ML	ECQ-VIH104JL3	
C818	UA654220	C. MYLAR	0.022uF	50V
C819	UA654220	C. MYLAR	0.022uF	50V
C820	VR168300	C. MYLAR. ML	ECQ-VIH104JL3	
C821	Vi845900	C. EL	10uF	63V
C822	VR168300	C. MYLAR. ML	ECQ-VIH104JL3	
C823	UA654220	C. MYLAR	0.022uF	50V
C824	Vi845900	C. EL	10uF	63V
C825	UA652100	C. MYLAR	100pF	50V
C826	UA652100	C. MYLAR	100pF	50V
C827	Vi845900	C. EL	10uF	63V
C829	Vi845100	C. EL	3.3uF	50V
C830	UA652100	C. MYLAR	100pF	50V
C831	Vi845900	C. EL	10uF	63V
C832	Vi846000	C. EL	22uF	63V
C833	Vi846000	C. EL	22uF	63V
C834	Vi845900	C. EL	10uF	63V
C835	Vi842400	C. EL	33uF	16V
C836	Vi842400	C. EL	33uF	16V
C837	FG251220	C. CE	22pF	50V
C838	FG212100	C. CE	100pF	50V
C839	Vi841800	C. EL	100uF	10V
C840	Vi841800	C. EL	100uF	10V
C841	FG212100	C. CE	100pF	50V
C842	FG251220	C. CE	22pF	50V
C843	Vi842900	C. EL	470uF	16V
C844	Vi842900	C. EL	470uF	16V
C845	VF466900	C. CE. TUBLR	470pF	50V
C846	VF466900	C. CE. TUBLR	470pF	50V
C847	VF467000	C. CE. TUBLR	1000pF	50V
C848	VF467300	C. CE. TUBLR	0.01uF	16V
C849	VF467300	C. CE. TUBLR	0.01uF	16V
C850	VF467000	C. CE. TUBLR	1000pF	50V
C851	VF467000	C. CE. TUBLR	1000pF	50V
C852	VF467300	C. CE. TUBLR	0.01uF	16V
C853	Vi845600	C. EL	47uF	50V
C854	Vi845600	C. EL	47uF	50V
C855	FG212100	C. CE	100pF	50V
C856	FG212100	C. CE	100pF	50V
C857	Vi842900	C. EL	470uF	16V
C858	Vi842900	C. EL	470uF	16V

* New Parts

P.C.B. FUNCTION

Schm Ref.	PART NO.	Description
D1	VG437400	DIODE. ZENR MTZJ5. 1B 5. 1V(ABG)
D2	VG437300	DIODE. ZENR MTZJ5. 1A 5. 1V
D3	VG437400	DIODE. ZENR MTZJ5. 1B 5. 1V
D4	VG438200	DIODE. ZENR MTZJ6. 8A 6. 8V
D5	iF004600	DIODE 1SS133
D6	iF004600	DIODE 1SS133
D7	iF004600	DIODE 1SS133
D8	VG437300	DIODE. ZENR MTZJ5. 1A 5. 1V
D9	iF004600	DIODE 1SS133
D10	iF004600	DIODE 1SS133
D11	iF004600	DIODE 1SS133
D12	iF004600	DIODE 1SS133
D301	VG436700	DIODE. ZENR MTZJ4. 3A 4. 3V
D302	VG437400	DIODE. ZENR MTZJ5. 1B 5. 1V
D801	VH770800	DIODE 1SR139-100
D802	VH770800	DIODE 1SR139-100
IC1	XR216B00	IC MAIN-CPU
IC2	XJ757A00	IC NJM78L05A-T3
IC3	XF291A00	IC uPC4570G2
IC4	XF291A00	IC uPC4570G2
IC5	XJ553A00	IC NJM2068MD
IC6	XJ553A00	IC NJM2068MD
IC7	XJ553A00	IC NJM2068MD
IC8	XJ553A00	IC NJM2068MD
IC9	XF291A00	IC uPC4570G2
IC10	XF291A00	IC uPC4570G2
IC11	XF291A00	IC uPC4570G2
IC12	XF291A00	IC uPC4570G2
IC13	XE518A00	IC uPC4574G2
IC14	XE518A00	IC uPC4574G2
IC15	XF291A00	IC uPC4570G2
IC16	XR219A00	IC LC7536
IC17	XR219A00	IC LC7536
IC18	XR219A00	IC LC7536
IC19	XR027A00	IC TC9162AN
IC20	XP896A00	IC LC78213
IC21	XF291A00	IC uPC4570G2
IC22	XF291A00	IC uPC4570G2
IC23	XF291A00	IC uPC4570G2
IC24	XE518A00	IC uPC4574G2
IC25	XE518A00	IC uPC4574G2
IC301	XF494A00	IC LB1641
IC302	XF494A00	IC LB1641
IC801	XM356A00	IC NJM2068LD
IC802	XB247301	IC uPC4570HA
IC803	XM356A00	IC NJM2068LD
IC804	XP844A00	IC NJM4556AL
JK801	VT034300	JACK 1P
JK802	VT749200	JACK. PHONE HLJ5307
* PJ801	VU459400	JACK. PIN 3P
Q1	VK432900	TR 2SD1915F S, T
Q2	VK432900	TR 2SD1915F S, T
Q3	VK432900	TR 2SD1915F S, T

* New Parts

Schm Ref.	PART NO.	Description
Q4	VK432900	TR 2SD1915F S, T
Q5	iC174020	TR 2SC1740S R, S
Q6	iA093320	TR 2SA933S Q, R
Q7	VG722000	TR. DGT DTC144ES
Q8	iA093320	TR 2SA933S Q, R
Q9	iA093320	TR 2SA933S Q, R
Q10	VK432900	TR 2SD1915F S, T
Q11	VK432900	TR 2SD1915F S, T
Q12	VK432900	TR 2SD1915F S, T
Q13	VK432900	TR 2SD1915F S, T
Q801	VK432900	TR 2SD1915F S, T
Q802	VK432900	TR 2SD1915F S, T
Q803	VK432900	TR 2SD1915F S, T
Q804	VK432900	TR 2SD1915F S, T
* SW301	VT904000	SW. RT SRBAA2A
SW801	VD357300	SW. PUSH SPUN12
* SW803	VT904100	SW. RT SRRM17
* VR1	VT882400	Y100KΩ
* VR801	VU145100	VR 16KΩ
* VR802	VU145200	VR 20KΩ
* VR803	VU145000	VR MN30KΩ
XL1	VE222400	RSNR. CE 8MHz
	VJ828000	PIN IMSA-6024-03E
	BB071360	SCR. TERM 8. 3x13

* New Parts

DSP-A3090

R.MTL.OXD, R.CAR.FP, R.CAR.CHP, R.MTL.CHP, R.MTL.PLAT & R.MTL.FLM

Schm Ref.	PART NO.	Description		
	HL312220	R. MTL. OXD	0.22Ω	1W
	HL314100	R. MTL. OXD	10Ω	1W
	HL315100	R. MTL. OXD	100Ω	1W
	HL315120	R. MTL. OXD	120Ω	1W
	HL315150	R. MTL. OXD	150Ω	1W
	HL315220	R. MTL. OXD	220Ω	1W
	HL316100	R. MTL. OXD	1KΩ	1W
	HV453100	R. CAR. FP	1Ω	1/4W
	HV453220	R. CAR. FP	2.2Ω	1/4W
	HV453330	R. CAR. FP	3.3Ω	1/4W
	HV453470	R. CAR. FP	4.7Ω	1/4W
	HV454100	R. CAR. FP	10Ω	1/4W
	HV454470	R. CAR. FP	47Ω	1/4W
	HV455100	R. CAR. FP	100Ω	1/4W
	HV455220	R. CAR. FP	220Ω	1/4W
	HV455680	R. CAR. FP	680Ω	1/4W
	HV456100	R. CAR. FP	1KΩ	1/4W
	HV456150	R. CAR. FP	1.5KΩ	1/4W
	HV456270	R. CAR. FP	2.7KΩ	1/4W
	HV456470	R. CAR. FP	4.7KΩ	1/4W
	HV456560	R. CAR. FP	5.6KΩ	1/4W
	HV457150	R. CAR. FP	15KΩ	1/4W
	RD250000	R. CAR. CHP	0Ω	1/10W
	RD253220	R. CAR. CHP	2.2Ω	1/10W
	RD254680	R. CAR. CHP	68Ω	1/10W
	RD254750	R. CAR. CHP	75Ω	1/10W
	RD254820	R. CAR. CHP	82Ω	1/10W
	RD255100	R. CAR. CHP	100Ω	1/10W
	RD255120	R. CAR. CHP	120Ω	1/10W
	RD255150	R. CAR. CHP	150Ω	1/10W
	RD255220	R. CAR. CHP	220Ω	1/10W
	RD255330	R. CAR. CHP	330Ω	1/10W
	RD255470	R. CAR. CHP	470Ω	1/10W
	RD255680	R. CAR. CHP	680Ω	1/10W
	RD256100	R. CAR. CHP	1KΩ	1/10W
	RD256220	R. CAR. CHP	2.2KΩ	1/10W
	RD256330	R. CAR. CHP	3.3KΩ	1/10W
	RD256390	R. CAR. CHP	3.9KΩ	1/10W
	RD256430	R. CAR. CHP	4.3KΩ	1/10W
	RD256470	R. CAR. CHP	4.7KΩ	1/10W
	RD256560	R. CAR. CHP	5.6KΩ	1/10W
	RD256680	R. CAR. CHP	6.8KΩ	1/10W
	RD256750	R. CAR. CHP	7.5KΩ	1/10W
	RD256820	R. CAR. CHP	8.2KΩ	1/10W
	RD256910	R. CAR. CHP	9.1KΩ	1/10W
	RD257100	R. CAR. CHP	10KΩ	1/10W
	RD257120	R. CAR. CHP	12KΩ	1/10W
	RD257180	R. CAR. CHP	18KΩ	1/10W
	RD257220	R. CAR. CHP	22KΩ	1/10W
	RD257470	R. CAR. CHP	47KΩ	1/10W
	RD257680	R. CAR. CHP	68KΩ	1/10W

* New Parts

Schm Ref.	PART NO.	Description		
	RD257820	R. CAR. CHP	82KΩ	1/10W
	RD258100	R. CAR. CHP	100KΩ	1/10W
	RD258220	R. CAR. CHP	220KΩ	1/10W
	RD259100	R. CAR. CHP	1MΩ	1/10W
	Vi190100	R. MTL. CHP	10Ω	1/10W
	Vi191500	R. MTL. CHP	39Ω	1/10W
	Vi191700	R. MTL. CHP	47Ω	1/10W
	Vi192400	R. MTL. CHP	91Ω	1/10W
	Vi192500	R. MTL. CHP	100Ω	1/10W
	Vi192600	R. MTL. CHP	110Ω	1/10W
	Vi192900	R. MTL. CHP	150Ω	1/10W
	Vi193300	R. MTL. CHP	220Ω	1/10W
	Vi193500	R. MTL. CHP	270Ω	1/10W
	Vi194100	R. MTL. CHP	470Ω	1/10W
	Vi194900	R. MTL. CHP	1KΩ	1/10W
*	Vi195000	R. MTL. CHP	1.1KΩ	1/10W
	Vi195100	R. MTL. CHP	1.2KΩ	1/10W
	Vi195300	R. MTL. CHP	1.5KΩ	1/10W
	Vi195500	R. MTL. CHP	1.8KΩ	1/10W
	Vi195700	R. MTL. CHP	2.2KΩ	1/10W
	Vi195800	R. MTL. CHP	2.4KΩ	1/10W
	Vi195900	R. MTL. CHP	2.7KΩ	1/10W
	Vi196100	R. MTL. CHP	3.3KΩ	1/10W
	Vi196400	R. MTL. CHP	3.9KΩ	1/10W
	Vi196600	R. MTL. CHP	4.7KΩ	1/10W
	Vi196700	R. MTL. CHP	5.1KΩ	1/10W
	Vi196800	R. MTL. CHP	5.6KΩ	1/10W
	Vi196900	R. MTL. CHP	6.2KΩ	1/10W
	Vi197000	R. MTL. CHP	6.8KΩ	1/10W
	Vi197200	R. MTL. CHP	8.2KΩ	1/10W
	Vi197400	R. MTL. CHP	10KΩ	1/10W
	Vi197600	R. MTL. CHP	12KΩ	1/10W
	Vi197800	R. MTL. CHP	15KΩ	1/10W
	Vi198000	R. MTL. CHP	18KΩ	1/10W
	Vi198100	R. MTL. CHP	20KΩ	1/10W
	Vi198200	R. MTL. CHP	22KΩ	1/10W
	Vi198600	R. MTL. CHP	33KΩ	1/10W
	Vi199000	R. MTL. CHP	47KΩ	1/10W
	Vi199200	R. MTL. CHP	56KΩ	1/10W
	Vi199600	R. MTL. CHP	82KΩ	1/10W
	Vi199900	R. MTL. CHP	91KΩ	1/10W
	Vi200000	R. MTL. CHP	100KΩ	1/10W
	VK581200	R. MTL. CHP	120KΩ	1/10W
	VK582000	R. MTL. CHP	270KΩ	1/10W
	VK582600	R. MTL. CHP	470KΩ	1/10W
	VK583400	R. MTL. CHP	1MΩ	1/10W
	VJ787600	R. MTL. PLAT	0.22Ω+0.22	5W
	VL794700	R. MTL. OXD	1Ω	1W
	VP939700	R. MTL. FLM	4.7Ω	1W
*	VU224200	R. MTL. FLM	0.47Ω	1W

* New Parts

EXPLODED VIEW

Note) When replacing the FL display (VT876400) included in ⑨(3), replace it together with the FL support (VU018900).

1

2

3

4

5

6

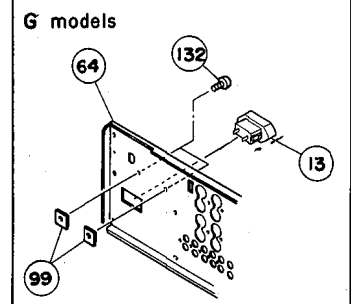
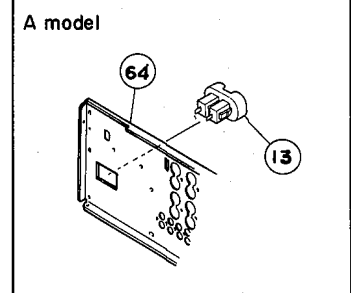
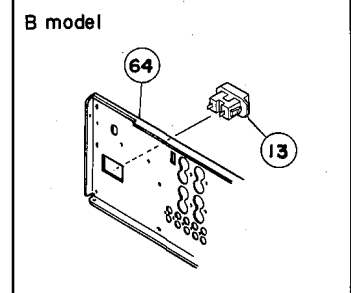
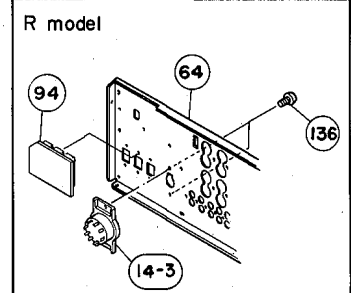
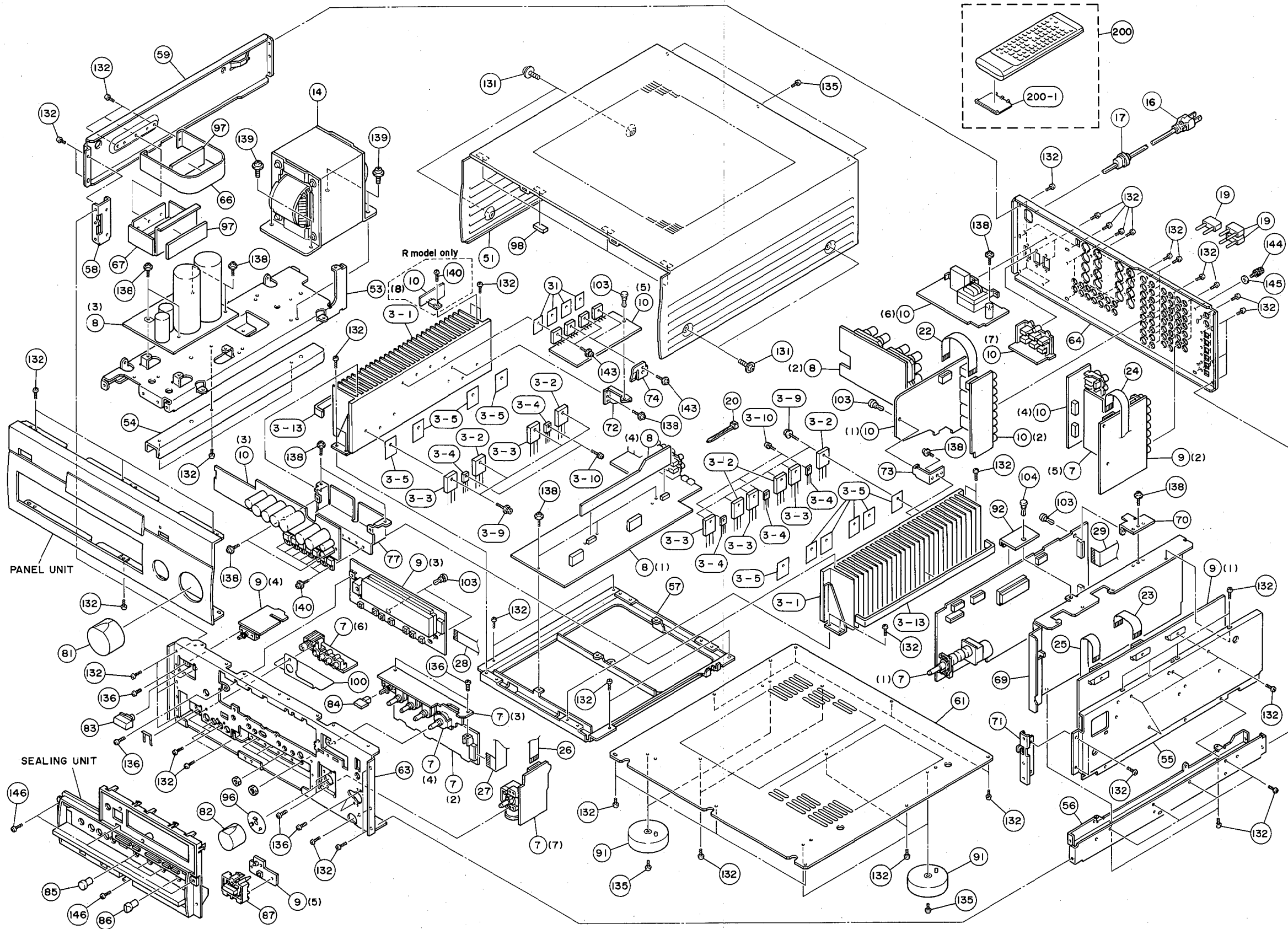

MECHANICAL PARTS

Ref. No.	PART NO.	Description	Remarks	Markets
* 3- 1	VU000600	HEAT SINK ASS'Y	52BS300-L90	
3- 2	iX801420	TRANSISTOR	2SA1302 O,R	Q369A, 374A, 378A
3- 2	iX801420	TRANSISTOR	2SA1302 O,R	, 380A, 382A
3- 3	iX801430	TRANSISTOR	2SC3281 O,R	Q369C, 374C, 378C
3- 3	iX801430	TRANSISTOR	2SC3281 O,R	, 380C, 382C
3- 4	VC398100	TRANSISTOR	2SC1846 S	Q325, 326, 348
3- 4	VC398100	TRANSISTOR	2SC1846 S	, 365, 372
3- 5	VK196000	SHEET	22x29	
3- 9	VK173200	SCREW, TRANSISTOR	3x15 SP FCM3	
3-10	VK697600	BIND HEAD B-TITE SCREW	3x10 SP ZMC2-Y	
* 3-13	VU195800	DAMPER, FIN		
* 7	VU177700	P. C. B. ASS'Y	FUNCTION	(UCR)
* 7	VU177800	P. C. B. ASS'Y	FUNCTION	(ABG)
* 8	VU178000	P. C. B. ASS'Y	MAIN	(UC)
* 8	VU178100	P. C. B. ASS'Y	MAIN	(R)
* 8	VU178200	P. C. B. ASS'Y	MAIN	(ABG)
* 9	VU178400	P. C. B. ASS'Y	DSP	(UCR)
* 9	VU178500	P. C. B. ASS'Y	DSP	(ABG)
* 10	VU178700	P. C. B. ASS'Y	VIDEO	(UC)
* 10	VU178800	P. C. B. ASS'Y	VIDEO	(R)
* 10	VU178900	P. C. B. ASS'Y	VIDEO	(A)
* 10	VU179000	P. C. B. ASS'Y	VIDEO	(B)
* 10	VU194300	P. C. B. ASS'Y	VIDEO	(G)
△ 13	VJ775000	AC OUILET	2P	(B)
△ 13	VJ775100	AC OUILET	2P	(G)
△ 13	VT915100	AC OUILET	2P	(A)
△* 14	XR554A00	POWER TRANSFORMER		(U)
△* 14	XR555A00	POWER TRANSFORMER		(C)
△* 14	XR557A00	POWER TRANSFORMER		(A)
△* 14	XR558A00	POWER TRANSFORMER		(BG)
△* 14-2	XR556A00	POWER TRANSFORMER		(R)
△ 14-3	Vi449800	VOLTAGE SELECTOR	ESE-37284-F	(R)
△ 16	VP418300	POWER CORD ASS'Y		(A)
△ 16	VQ458400	POWER CORD ASS'Y		(R)
△ 16	VS759300	POWER CORD ASS'Y		(G)
△* 16	VU122900	POWER CORD ASS'Y		(C)
△* 16	VU411300	POWER CORD ASS'Y		(B)
17	VN158600	CORD STOPPER	No. 2104	(RG)
19	LB101890	SHORT PLUG		
20	CB069250	BINDING TIE	BK-1	
22	VN024000	CONNECTOR, FLAT CABLE	14P 60mm	
* 23	VU145300	CONNECTOR, FLAT CABLE	11P 60mm	
* 24	VU145400	CONNECTOR, FLAT CABLE	11P 180mm	
* 25	VU145500	CONNECTOR, FLAT CABLE	12P 280mm	
* 26	VU145600	CONNECTOR, FLAT CABLE	13P 100mm	
* 27	VU145700	CONNECTOR, FLAT CABLE	15P 230mm	
* 28	VU145800	CONNECTOR, FLAT CABLE	19P 250mm	
* 29	VU145900	CONNECTOR, FLAT CABLE	19P 350mm	
31	VK195900	SHEET	19x24	
51	VT059800	TOP COVER		BL
* 51	VT997400	TOP COVER		TI
53	VJ892600	FRAME	L	
* 54	VU120700	FRAME, L/SF		

* New Parts

DSP-A3090

Ref. No.	PART NO.	Description	Remarks	Markets
55	VK380200	FRAME		
56	VK380300	FRAME		
* 57	VT999300	FRAME, CENTER A		
58	VJ895500	FRAME	A	
59	VJ895600	FRAME	B	
61	VJ893400	BOTTOM COVER		
* 63	VT999400	SUB CHASSIS		
* 64	VT997600	REAR PANEL		(U)
* 64	VT997700	REAR PANEL		(R)
* 64	VT997800	REAR PANEL		(A)
* 64	VT997900	REAR PANEL		(BG)
* 64	VU124600	REAR PANEL		(C)
66	VK390900	SUPPORT		
67	VK391000	SUPPORT		
* 69	VT999500	SHIELD CASE	/DSP	
* 70	VT999600	SUPPORT	I/PCB	
* 71	VT999700	SUPPORT	R/FR	
* 72	VU120500	SUPPORT	E/PCB	
* 73	VU120600	SUPPORT	S/PCB	
* 74	VU196100	SUPPORT, TR	AMP	
* 77	VU000500	HEAT SINK	/PS	
* 81	VU017800	KNOB, LED	D45	BL
* 81	VU017900	KNOB, LED	D45	TI
82	VS126500	KNOB, LED	D31	BL
82	VS126600	KNOB, LED	D31	TI
83	VQ780000	BUTTON		BL
83	VT990000	BUTTON		TI
84	VQ779000	BUTTON	3x14	BL
84	VU103000	BUTTON		TI
85	VS757200	KNOB, P	D12	BL
85	VS757300	KNOB, P	D12	TI
86	VT275100	KNOB	D12	BL
86	VT275200	KNOB, R	D12	TI
* 87	VU018500	BUTTON, T2		BL
* 87	VU018600	BUTTON, T2		TI
91	VK724100	LEG ASS'Y		
92	VJ895900	SUPPORT	PCB	
* 94	VU195900	SHET	R-OUTLET	(R)
* 96	VU196000	PLATE, LED	INPUT	
97	VK492200	DAMPER	A	
98	VE222600	CUSHION		
99	Vi707300	DAMPER		(G)
* 100	VU481900	SHIELD PLATE	/PJ	
103	CB605620	PLASTIC RIVET	No. 1781	
104	CB068880	PLASTIC RIVET	No. 1027	
131	EK365090	BW HEAD SCREW	4x8 ZMC2-BL	BL
131	EX601150	BW HEAD S-TITE SCREW	4x8-10 FNM3-BL	TI
132	VN413300	BIND HEAD BONDING B-T. SCREW	3x8 MFZN2-BL	
135	EP600190	BIND HEAD B-TITE SCREW	3x8 ZMC2-BL	
136	ED330066	BIND HEAD SCREW	3x6 FCRM3-BL	
138	EK930010	PW HEAD B-TITE SCREW	3x8-8 FCRM3-BL	
139	VK625000	CUP S-TITE SCREW	5x10-12 ZMC2-Y	
140	VK697600	BIND HEAD B-TITE SCREW	3x10 SP ZMC2-Y	

* New Parts

Ref. No.	PART NO.	Description	Remarks	Markets
143	VK173200	SCREW, TRANSISTOR	3x15 SP FCM3	
144	AA627310	GROUND TERMINAL		
145	EV265560	PLAIN WASHER	3.6x10x0.8 FNM3-3G	
146	EP600140	BIND HEAD B-TITE SCREW	3x10 MFZN2-BL	
		ACCESSORIES		
* 200	VT974300	REMOTE CONTROL TRANSMITTER		(7A, 7D)
200-1	CX676010	LID		
*		BATTERY, ALKALINE MANGANESE	LR6, AA	

* New Parts

DSP-A3090

DSP-A3090

1

■ EXPLODED VIEW (Panel Section)

2

3

4

5

6

7

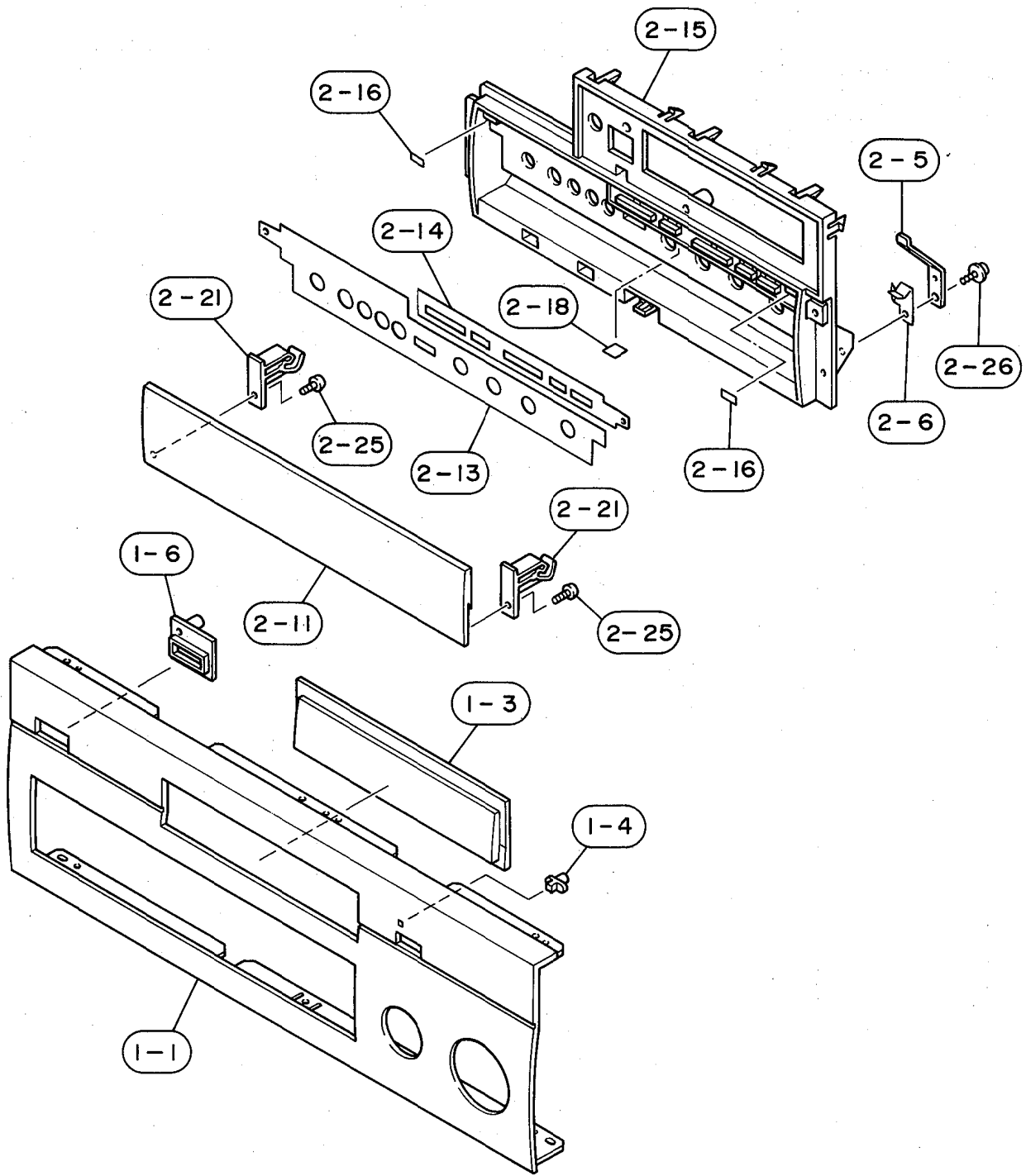

■ MECHANICAL PARTS (Panel Section)

Ref. No.	PART NO.	Description	Remarks	Markets
* 1- 1	VU016600	FRONT PANEL	BL	
* 1- 1	VU016700	FRONT PANEL	TI	
* 1- 3	VU018700	WINDOW PANEL, LID		(UCR)
* 1- 3	VU018800	WINDOW PANEL, LID		(ABG)
1- 4	Vi777100	LENS		
1- 6	VH816700	BUTTON GUIDE	10x25	BL
1- 6	VH816800	BUTTON GUIDE	10x25	TI
2- 5	VJ888200	SPRING		
2- 6	VK689800	GROUND PLATE	R	
* 2-11	VU017200	PANEL, LID	BL	
* 2-11	VU017300	PANEL, LID	TI	
* 2-13	VU017400	PLATE, L	BL	
* 2-13	VU017500	PLATE, L	TI	
* 2-14	VU017600	PLATE, SP	BL	
* 2-14	VU017700	PLATE, SP	TI	
* 2-15	VU018300	CASE, SUB PANEL	BL	
* 2-15	VU018400	CASE, SUB PANEL	TI	
2-16	VT062900	CUSHION	BL	
* 2-16	VU182300	CUSHION, LID	TI	
2-18	VH625500	DAMPER		
2-21	VJ888000	STOPPER	TI	
2-21	VJ888100	STOPPER	BL	
2-25	ED330066	BIND HEAD SCREW	3x6 FCRM3-BL	
2-26	EX601280	PW HEAD P-TITE SCREW	3x8-8 FCRM3-BL	

* New Parts

DSP-A3090

Parts List for Carbon Resistors

Value	1/4W Type Part No.	1/6W Type Part No.	Value	1/4W Type Part No.	1/6W Type Part No.
1.0 Ω	HJ35 3100	HF85 3100	10 kΩ	HF45 7100	HF45 7100
1.8 Ω	HJ35 3180	*	11 kΩ	HF45 7110	HF45 7110
2.2 Ω	HJ35 3220	HF85 3220	12 kΩ	HJ35 7120	HF85 7120
3.3 Ω	HJ35 3330	HF85 3330	13 kΩ	HF45 7130	HF45 7130
4.7 Ω	HJ35 3470	HF85 3470	15 kΩ	HF45 7150	HF45 7150
5.6 Ω	HJ35 3560	HF85 3560	18 kΩ	HF45 7180	HF45 7180
10 Ω	HF45 4100	HF45 4100	22 kΩ	HF45 7220	HF45 7220
15 Ω	HJ35 4150	HF85 4150	24 kΩ	HF45 7240	HF45 7240
22 Ω	HF45 4220	HF45 4220	27 kΩ	HJ35 7270	HF85 7270
27 Ω	HJ35 4270	HF85 4270	30 kΩ	HF45 7300	HF45 7300
33 Ω	HF45 4330	HF45 4330	33 kΩ	HF45 7330	HF45 7330
39 Ω	HJ35 4470	HF85 4390	36 kΩ	HF45 7360	HF45 7360
47 Ω	HF45 4470	HF45 4470	39 kΩ	HF45 7390	HF45 7390
56 Ω	HF45 4560	HF45 4560	47 kΩ	HF45 7470	HF45 7470
68 Ω	HF45 4680	HF45 4680	51 kΩ	HF45 7510	HF45 7510
75 Ω	HF45 4750	HF45 4750	56 kΩ	HF45 7560	HF45 7560
82 Ω	HF45 4820	HF45 4820	62 kΩ	HF45 7620	HF45 7620
91 Ω	HF45 4910	HF45 4910	68 kΩ	HF45 7680	HF45 7680
100 Ω	HF45 5100	HF45 5100	82 kΩ	HF45 7820	HF45 7820
110 Ω	HJ35 5110	HF85 5110	91 kΩ	HF45 7910	HF45 7910
120 Ω	HF45 5120	HF45 5120	100 kΩ	HF45 8100	HF45 8100
150 Ω	HF45 5150	HF45 5150	110 kΩ	HF45 8110	HF45 8110
160 Ω	HJ35 5160	*	120 kΩ	HF45 8120	HF45 8120
180 Ω	HF45 5180	HF45 5180	150 kΩ	HF45 8150	HF45 8150
200 Ω	HF45 5200	HF45 5200	180 kΩ	HF45 8180	HF45 8180
220 Ω	HF45 5220	HF45 5220	220 kΩ	HJ35 8220	HF85 8220
270 Ω	HF45 5270	HF45 5270	270 kΩ	HF45 8270	HF45 8270
330 Ω	HF45 5330	HF45 5330	300 kΩ	HF45 8300	HF45 8300
390 Ω	HF45 5390	HF45 5390	330 kΩ	HF45 8330	HF45 8330
430 Ω	HF45 5430	HF45 5430	390 kΩ	HJ35 8390	HF85 8390
470 Ω	HF45 5470	HF45 5470	470 kΩ	HF45 8470	HF45 8470
510 Ω	HF45 5510	HF45 5510	560 kΩ	HJ35 8560	HF85 8560
560 Ω	HF45 5560	HF45 5560	680 kΩ	HJ35 8680	HF85 8680
680 Ω	HF45 5680	HF45 5680	820 kΩ	HJ35 8820	HF85 8820
820 Ω	HF45 5820	HF45 5820	1.0 MΩ	HF45 9100	HF45 9100
910 Ω	HF45 5910	HF45 5910	1.2 MΩ	HJ35 9120	*
1.0 kΩ	HF45 6100	HF45 6100	1.5 MΩ	HJ35 9150	HF85 9150
1.2 kΩ	HF45 6120	HF45 6120	1.8 MΩ	HJ35 9180	HF85 9180
1.5 kΩ	HF45 6150	HF45 6150	2.2 MΩ	HJ35 9220	HF85 9220
1.8 kΩ	HF45 6180	HF45 6180	3.3 MΩ	HJ35 9330	HF85 9330
2.0 kΩ	HJ35 6200	HF85 6200	3.9 MΩ	HJ35 9390	*
2.2 kΩ	HF45 6220	HF45 6220	4.7 MΩ	HJ35 9470	HF85 9470
2.4 kΩ	HJ35 6240	HF85 6240			
2.7 kΩ	HF45 6270	HF45 6270			
3.0 kΩ	HF45 6300	HF45 6300			
3.3 kΩ	HF45 6330	HF45 6330			
3.6 kΩ	HJ35 6360	HF85 6360			
3.9 kΩ	HF45 6390	HF45 6390			
4.7 kΩ	HF45 6470	HF45 6470			
5.1 kΩ	HF45 6510	HF45 6510			
5.6 kΩ	HF45 6560	HF45 6560			
6.8 kΩ	HF45 6680	HF45 6680			
8.2 kΩ	HF45 6820	HF45 6820			
9.1 kΩ	HF45 6910	HF45 6910			

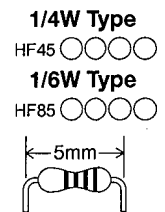
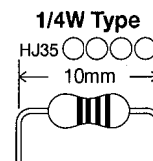

DSP-A3090